

Operation Manual

TBG 620

0299 9084 EN, 02/2006



Engine Number:

--	--	--	--	--	--	--	--	--	--

Please enter your engine number here. This will help us to serve you better in questions of repairs, spare parts and after-sales service generally.

We reserve the right to make technical alterations to the drawings and particulars in this documentation package, if this should become necessary to improve the engines. Reprints and duplication of any kind, either in whole or in part, require our written permission.

DEUTZ POWER SYSTEMS

This documentation is intended for the following engine

' Engine type:

--	--	--	--	--	--	--	--	--	--	--	--	--	--	--	--	--	--	--	--

' Type of application:

--	--	--	--	--	--	--	--	--	--	--	--	--	--	--	--	--	--	--	--

' System name:

--	--	--	--	--	--	--	--	--	--	--	--	--	--	--	--	--	--	--	--

' Power:

--	--	--	--

 kW

' Speed:

--	--	--	--

 min⁻¹

' Commissioned on:

--	--

--	--

--	--	--	--

Please enter data. This will make it a lot easier for us to process after-sales support, repair work and spare parts orders.

The documentation should be presented to the responsible service partner for every service assignment.

Imprint:

DEUTZ Power Systems GmbH & Co. KG

Service MS

Carl-Benz-Straße 1

D-68167 Mannheim

Tel.: +49 (0) 6 21 3 84-0

Fax: +49 (0) 6 21 3 84-88 41

<http://www.deutzpowersystems.com>

Printed in Germany

All rights reserved

Publication date:

© 02/2006

Ordering No:

0299 9084 EN

Introduction

Please read and keep in mind...

- Read and keep to the information in this documentation. You will avoid accidents, retain the manufacturer's warranty and have a fully functional, ready-to-use engine at your disposal.
- This engine is built exclusively for the purpose intended according to the scope of delivery as defined by the equipment manufacturer (use for the intended purpose). Any use above and beyond this is considered improper use. The manufacturer will not be liable for damages resulting from this. The user will bear the sole risk in this case.
- Use for the intended purpose also includes observance of the operating, maintenance and repair instructions specified by the manufacturer. The engine may only be used, maintained and repaired by persons who are familiar with it and instructed in the dangers.
- Make sure that this documentation is available to everyone involved in the operation, maintenance and repair and that they have understood the contents.
- Non-compliance with this documentation package may lead to malfunctions and damage to your engine, or even injury to persons, for which the manufacturer will not accept any liability.
- A prerequisite for proper maintenance and repair is the availability of all necessary equipment, hand tools and special tools. All equipment and tools must be in perfect working condition.
- Engine parts such as springs, clamps, elastic retaining rings etc. constitute an increased risk of injury when not used properly.
- The relevant rules for the prevention of accidents and other generally recognised safety and industrial medicine rules must be followed.
- Maximum cost-effectiveness, reliability and long life is only guaranteed when DEUTZ Power Systems original parts are used.
- Repair of the engine must comply with use for the intended purpose. Only parts released for the purpose by the manufacturer may be used for conversion work. Unauthorised modifications to the engine exclude manufacturer liability for resulting damages.

Take care when the engine is running

Carry out maintenance or repair work only when the engine is at a standstill. If you remove any protective features, fit them back in place on completion of the work concerned. When working on the running engine, work clothing must be close-fitting.

Safety



You will find this symbol next to all safety instructions. Follow these meticulously. The attention of operating personnel should be drawn to these safety instructions. In addition, general statutory safety and accident prevention regulations applying in your country must be complied with.

Note



You will find this symbol next to instructions of a general nature. Follow these meticulously.

Asbestos



Gaskets used in this engine are asbestos-free. Please use appropriate spare parts for maintenance and repair work.

Foreword

Dear Customer,

Deutz Power Systems engines are designed for a large number of applications. A wide range of variants ensures that the special requirements of each customer are met.

Your engine is appropriately equipped for your requirements, which means that not all of the components described in this manual are necessarily fitted to your engine.

We have endeavoured to highlight any differences so that you will be able to locate the operating and maintenance instructions relevant to your engine quickly and easily.

Please read this documentation before starting your engine, and always follow the operating and maintenance instructions.

We are at your service for any questions you may have.

Your

DEUTZ Power Systems Service

The engines of DEUTZ Power Systems

DEUTZ Power Systems engines are the product of many years of research and development. The profound know-how gained in connection with high-quality requirements is our guarantee for the manufacture of engines with a long life, high reliability and low fuel consumption. Naturally the high requirements for environmental protection are also met.

Maintenance and care

Good service and maintenance will ensure that the engine continues to satisfy your requirements. Recommended service intervals must be observed and maintenance work carried out conscientiously. If the engine becomes difficult to operate, or if operating conditions deviate from normal, it is particularly important to take steps to find out the cause.

DEUTZ Power Systems Service

Please consult one of our service representatives responsible for operating faults and questions on spare parts. Our trained specialist personnel ensures fast, professional repairs using original parts in the event of damage.

Original parts from DEUTZ Power Systems are always manufactured according to the latest standards in technology.

Information about our service can be found at the end of this manual.

Contents

0 Introduction

Please read and keep in mind.....	0-1
Take care when the engine is running.....	0-2
Foreword.....	0-3
The engines of DEUTZ Power Systems.....	0-3
Maintenance and care.....	0-3
DEUTZ Power Systems Service.....	0-3

1 User notes

General.....	1-3
Regulations.....	1-3
Safety Regulations / Rules for Accident Prevention.....	1-3
Rules for disposal.....	1-4
Operating manual and workshop manual.....	1-5
Operating Manual.....	1-5
Workshop Manual.....	1-6
Job cards.....	1-7
Spare parts.....	1-8

2 Description

Type and designations.....	2-3
Type designation.....	2-3
Name plate.....	2-4
Position on the engine.....	2-4
Figure, rating plate.....	2-5
Designation of the engines sides, cylinder numbering and direction of rotation.....	2-6
Engine and unit illustrations.....	2-7
Design and function.....	2-14
Cylinder head.....	2-14
Channel guide.....	2-15
Drive system.....	2-15
Crankcase.....	2-15
Engine control and wheel drive.....	2-16
Speed control.....	2-16
Actuator.....	2-17
V12 and V16 engine with StG 30.....	2-17
V20 engine with StG 2080.....	2-18
Installation location.....	2-19
Charging.....	2-20
Schematic diagram of turbocharging.....	2-20
Compressor bypass.....	2-21
Gas system.....	2-23
Gas control line.....	2-23
Automatic shutoff process.....	2-24
Assembly and testing.....	2-24
Instructions for installation.....	2-24

Gas / air mixer, mixture formation.....	2-26
Lube oil system.....	2-28
Lube oil level switch.....	2-28
Crankcase bleed valve.....	2-29
Model AS 500 - Dynapure.....	2-29
Cooling system.....	2-30
Compressed air system.....	2-31
Compressed air starter.....	2-31
Electrical system.....	2-32
Ignition system.....	2-32
Electrical starter.....	2-33
Terminal assignment plans TEM Evolution.....	2-34
Electrical components.....	2-36

3 Operation

Work prior to first commissioning and after every inspection.....	3-3
General.....	3-3
Filling of coolant.....	3-3
Filling of lube oil.....	3-3
Pre-lubrication.....	3-4
Gas supply.....	3-4
Note for all heat transformers.....	3-4
Exhaust side.....	3-4
Note for oxidation catalyst.....	3-4
Commissioning / Starting.....	3-5
Starting.....	3-5
Warming up.....	3-5
Room ventilation.....	3-5
Lube oil system.....	3-5
Monitoring operation.....	3-6
System monitoring.....	3-6
Engine Peripheral Systems.....	3-6
Coolant circuit.....	3-6
Batteries.....	3-6

4 Operating media

General.....	4-3
Guarantee.....	4-3
Product selection.....	4-3
Mixability.....	4-3
Fuel gas.....	4-3
Lube oil.....	4-3
Engine coolant.....	4-3
Aids.....	4-5
Sealants and Locking Agents.....	4-5
Gluing Agents.....	4-8
Lubricants.....	4-9
Other Aids.....	4-9

5 Maintenance

Continuous supervision	5-3
Maintenance schedule	5-3
General	5-3
Selection and structure	5-4
Deutz maintenance and service schedules	5-4
Definition of activities in the maintenance schedule	5-5
Gas groups	5-5
Silicon content	5-6
Overview of specific maintenance schedules	5-7
Maintenance schedule 1	5-11
Maintenance work independent of operating hours	5-11
Maintenance work depending on operating hours	5-12
Maintenance work dependent on operating hours outside the DEUTZ maintenance and service schedules	5-14
Proof of maintenance performed	5-15
Copy form for maintenance work independent of operating hours	5-15
Table for maintenance work dependent on operating hours	5-16
Maintenance schedule 2	5-19
Maintenance work independent of operating hours	5-19
Maintenance work depending on operating hours	5-20
Maintenance work dependent on operating hours outside the DEUTZ maintenance and service schedules	5-22
Proof of maintenance performed	5-23
Copy form for maintenance work independent of operating hours	5-23
Table for maintenance work dependent on operating hours	5-24
Maintenance schedule 3	5-27
Maintenance work independent of operating hours	5-27
Maintenance work depending on operating hours	5-28
Maintenance work dependent on operating hours outside the DEUTZ maintenance and service schedules	5-30
Proof of maintenance performed	5-31
Copy form for maintenance work independent of operating hours	5-31
Table for maintenance work dependent on operating hours	5-32
Maintenance schedule 4	5-35
Maintenance work independent of operating hours	5-35
Maintenance work depending on operating hours	5-36
Maintenance work dependent on operating hours outside the DEUTZ maintenance and service schedules	5-38
Proof of maintenance performed	5-39
Copy form for maintenance work independent of operating hours	5-39
Table for maintenance work dependent on operating hours	5-40
Operating check log	5-43
Operating check log (form for copying)	5-44
Tools for competence class 1	5-45
Order address	5-45
Tools sorted according to order numbers	5-45

6 Troubleshooting

Fault table	6-3
-------------------	-----

Troubleshooting remedies	6-4
Engine fails to start	6-4
Engine does not reach the specified output or speed.....	6-4
Engine fires irregularly	6-4
Engine "knocks" and runs intermittently.....	6-5
Engine stops suddenly or is switched off by TEM after a fault	6-5
Engine gets too hot or TEM indicates "lack of coolant"	6-6
Lube oil pressure too low / TEM "Lube oil pressure too low" or "Lube oil level too low"	6-6
Coolant in lube oil	6-6
Lube oil in coolant.....	6-7
7 Preservation	
Technical Circular TC 0199-99-2116.....	7-3
8 Specifications	
Test and setting values.....	8-3
Tightening specifications	8-9
9 Job cards	
Symbol description	9-3
Job card list.....	9-4
Service	

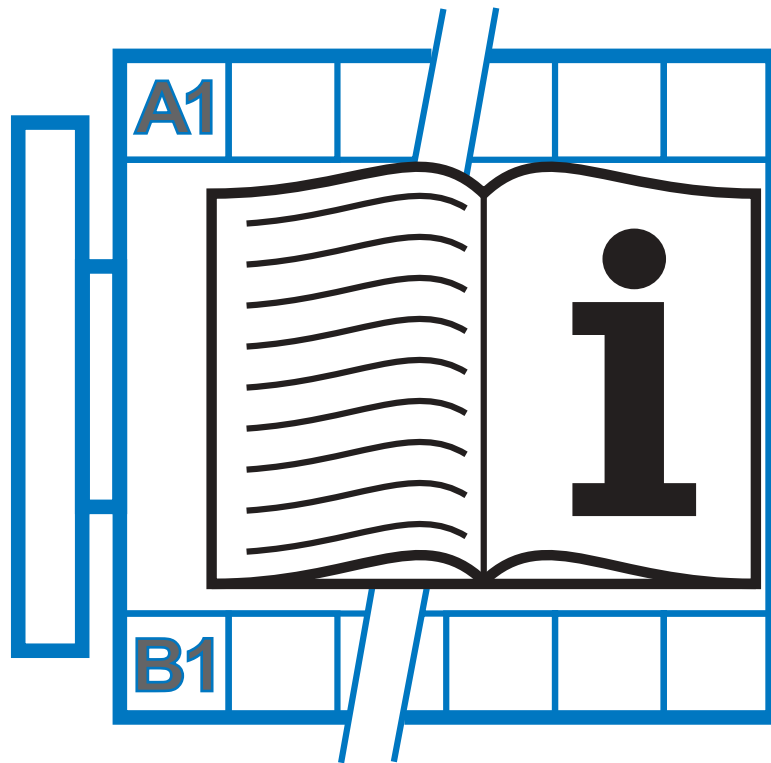



User notes

General

The maintenance and service work prescribed in the operation manual and the workshop manual must be performed on schedule and in full.

The maintenance and service personnel must have the necessary technical knowledge to perform the work. Safety and protection devices which may have to be removed during maintenance and service work must be replaced afterwards.



The rules for the prevention of accidents and the safety regulations must be observed at all times during maintenance and service work.

Please also observe the special safety regulations for the various service groups which are listed in detail as work cards in the Job Cards chapter (cf. also chapter 1 Safety Regulations / Rules for Accident Prevention).

The maintenance intervals can be taken from the maintenance schedules. These also provide information about the work to be performed.

The job cards provide technical hints for performing the work.

Regulations

Safety Regulations / Rules for Accident Prevention

Detailed safety instructions have been compiled for various service groups in the form of job cards, these precede the job cards of the respective service groups.

The legally prescribed rules for accident prevention (available from the appropriate associations or technical publishers) must be observed. These will depend on the location, the operating mode and the supplies and expendables used.

Special safety measures dependent on the respective work are specified and highlighted in the work description.

It generally applies among other things:

· for personnel:

- Only instructed personnel may operate or maintain the engine. Unauthorized persons must not enter the engine room.
- Wear tight fitting clothing and ear protectors in the engine room when engines are running.
- Only employ qualified personnel for repairs or service work.

· for the engine room:

- Make sure it is properly ventilated (do not cover the ventilation shafts).
- Provide a first aid kit and suitable fire extinguishers. Check filling and operational readiness at regular intervals.
- Only store inflammable materials in the engine room which are necessary for operating the system.
- Smoking and naked lights are prohibited in the engine room.

· for operation and maintenance of the engine:

- Only start the engine when all safety devices have been fitted and the turning gear has been removed. Make sure there is no-one in the danger zone.

- **Only perform cleaning, maintenance and repair work when the engine is switched off and secured against starting up.**

Rules for disposal

The work described in the operation manual and workshop manual necessitate the renewal of parts and operating media among other things. These renewed parts / operating media must be properly stored, transported and disposed of. The owner is responsible for this.

Disposal includes recycling and disposal of parts / operating media whereby recycling has priority.

The details of disposal and its supervision are governed by regional, national and international laws and decrees which the plant owner is responsible for observing.

Operating manual and workshop manual

To structure the information to suit the user, the service documentation is divided into operating manual and workshop manual.

Operating Manual

The Operating Manual contains a general description of the engine as well as instructions for the necessary maintenance measures and so on. The maintenance measures described in the Operation Manual can be performed by technically skilled personnel.

The chapters of the operating manual are as follows:

- 0 Introduction
 - Contents
- 1 User notes
- 2 Description (description of the engine and components)
- 3 Operation (operating the engine)
- 4 Operating media (operating media, auxiliary materials and operating media specifications under "Technical Bulletin")
- 5 Maintenance (maintenance schedules and special tools up to Deutz maintenance and service schedule E40)
- 6 Troubleshooting
- 7 Preservation ("Technical Bulletin")
- 8 Technical data (technical data on the engine, tightening specifications and test and setting values up to Deutz maintenance and service schedule E40)
- 9 Job cards (job card list, job cards for maintenance work up to Deutz maintenance and service schedule E40 in numerical order)
- 10 Miscellaneous (this is an optional chapter only enclosed if needed, containing supplementary documentation)
 - Service
 - General safety regulations

Workshop Manual

The workshop manual contains all the same chapters as the operating manual, with the addition of the instructions required for maintenance work from Deutz maintenance and service schedule E40 onwards. The maintenance measures from schedule E40 onwards, as described in the workshop manual, may only be performed by authorised personnel.

The chapters of the workshop manual are as follows:

- 0 Introduction
Contents
- 1 User notes
- 2 Description (description of the engine and components)
- 3 Operation (operating the engine)
- 4 Operating media (operating media, auxiliary materials and operating media specifications under "Technical Bulletin")
- 5 Maintenance (maintenance schedules, special tools as required by all Deutz maintenance and service schedules)
- 6 Troubleshooting
- 7 Preservation ("Technical Bulletin")
- 8 Technical data (technical data of the engine, tightening specifications and test and setting values as required by all Deutz maintenance and service schedules)
- 9 Job cards (job card list, job cards for maintenance work from all Deutz maintenance and service schedules in numerical order)
- 10 Miscellaneous (this is an optional chapter only enclosed if needed, containing supplementary documentation)
Service
General safety regulations

Job cards

All job cards have a job card number which is associated with a defined work procedure. An overview of the numbering system follows: The structure of the job card is shown in the illustration on the next page.

Differentiation of the job cards
The first letter stands for the competence required to perform the maintenance work.

- B** Operating manual: to be carried out by technically skilled personnel only
- W** Workshop manual: to be carried out by authorised personnel only
- I** Repair: to be carried out by authorised Service Centres only.

Maintenance group

- 0 General
- 1 Cylinder head
- 2 Drive system
- 3 Crankcase
- 4 Engine control
- 5 Speed governing
- 6 Exhaust system / Charging
- 7 Fuel system
- 8 Lube oil system
- 9 Coolant system
- 10 Compressed air system
- 11 Monitoring system
- 12 Other components
- 13 Electrical system

Subsystem (component)

The subsystem differs depending on the maintenance group.

Consecutive number

- Counting per subsystem (component)
- Different activities in the subsystem (component)
- Version differences

B 3-3-3

T 1-1 Numbering of job cards

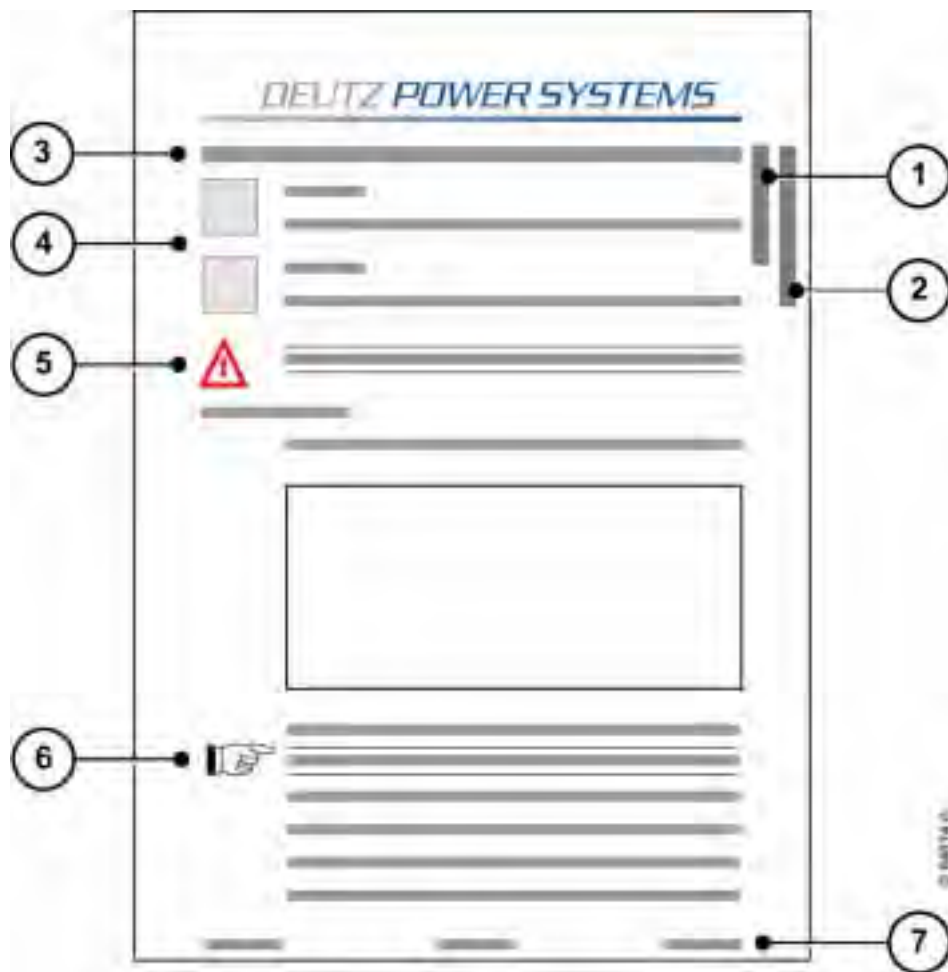

A 1-1 Structure of the job cards



For inquiries about job cards please always give the engine type or system 1, the number of the job card 2 and the date of issue 7.

- 1 Engine type or system
- 2 Number of the job card
- 3 Title of the job card
- 4 Tools, aids, spare parts and references
- 5 Safety instructions
- 6 General notes
- 7 Date of issue of the job card

Spare parts

Spares are available from DEUTZ Service. You will find a list of spares in the spare parts list of the engine or the system. You will find further information in the Service chapter at the end of the Operation Manual or Workshop Manual.

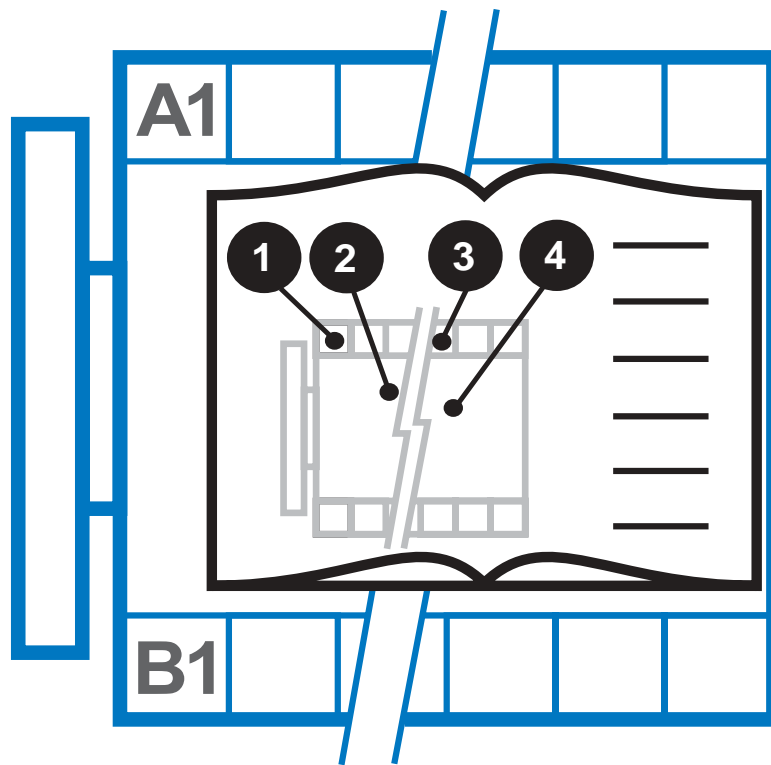

Description
TBG 620



Description

Type and designations

The engines in this series are water-cooled four-stroke, high-performance Otto gas engines which can be used in a wide range of drive applications with easy usability of the coolant and exhaust heat in force-heat coupling processes. A special low exhaust emission combustion process has been developed for environmental protection.

Type designation

See also rating plate		T	B	G	620	V	-	K
Turbocharger	T							
Mixture charge cooling	B							
Gas engine	G							
Series	620							
V-engine	V							
No. of cylinders	12, 16 or 20							
Two circuit cooling	K							

Name plate

Position on the engine

The rating plate is fixed to the engine. The engine number is punched additionally.

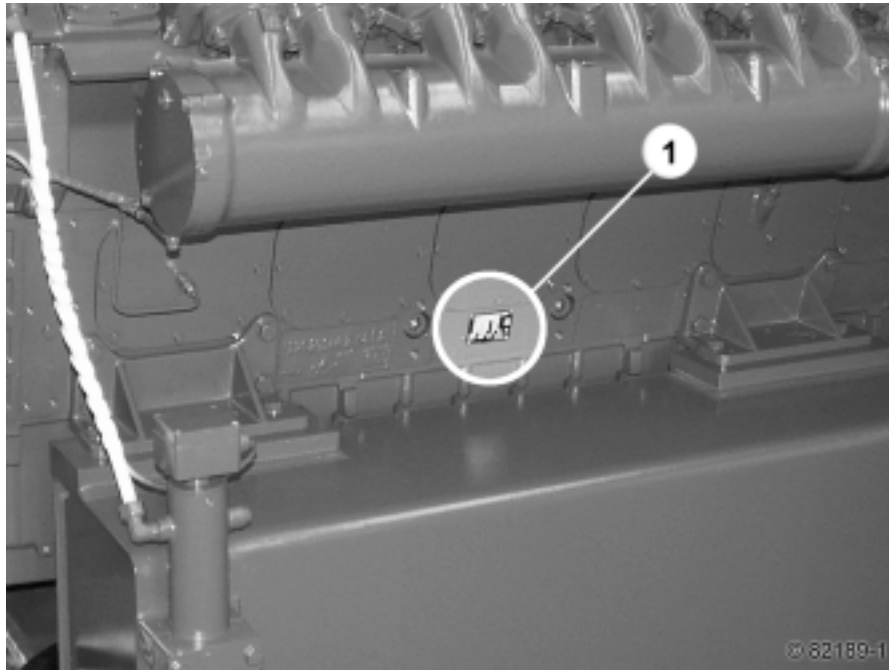

A 2-1 Position of the rating plate on the engine

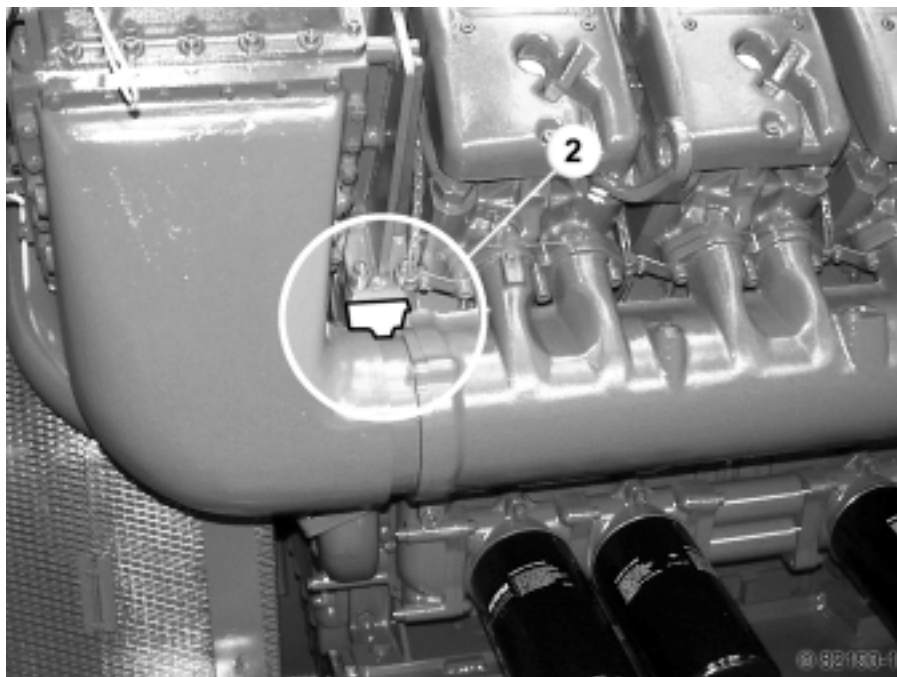

A 2-2 Position of the engine number on the engine

Figure, rating plate

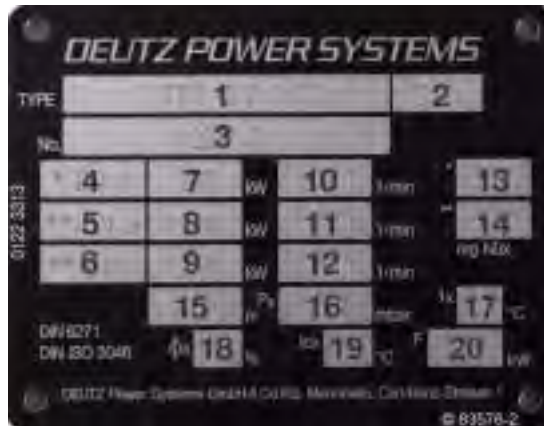

A 2-3 Figure, rating plate

- 1 Engine type designation
 - 2 Year
 - 3 Engine number
 - 4, 5, 6 Performance abbreviation according to DIN ISO 3046 Part 7 and abbreviation for the gas type¹⁾. A * or ** in front of the performance abbreviation refers to the corresponding NOx emission, see 13, 14.
 - 7, 8, 9 Numeric value of the performance in kW
 - 10, 11, 12 Engine speed in rpm
 - 13, 14 NOx emission in mg
 - 15 Height above sea level (conditions at installation site)
 - 16 Air pressure px in mbar (conditions at installation site)
 - 17 Charge air coolant temperature tcx in °C (conditions at installation site)
 - 18 Relative humidityΦx in % (conditions at installation site)
 - 19 Mixture coolant temperature tcx in °C (conditions at installation site)
 - 20 Numeric value of performance of the oil pump in kW (F)
-
- 1) Abbreviation for gas type
 - n natural gas
 - s sewage gas
 - l methane gas
 - m pit gas
 - p propane gas

Designation of the engines sides, cylinder numbering and direction of rotation

The designation used in this operating manual is highlighted respectively in bold print and corresponds with DIN ISO 1204.

The four sides of the engine normally carry the following designations in practice:

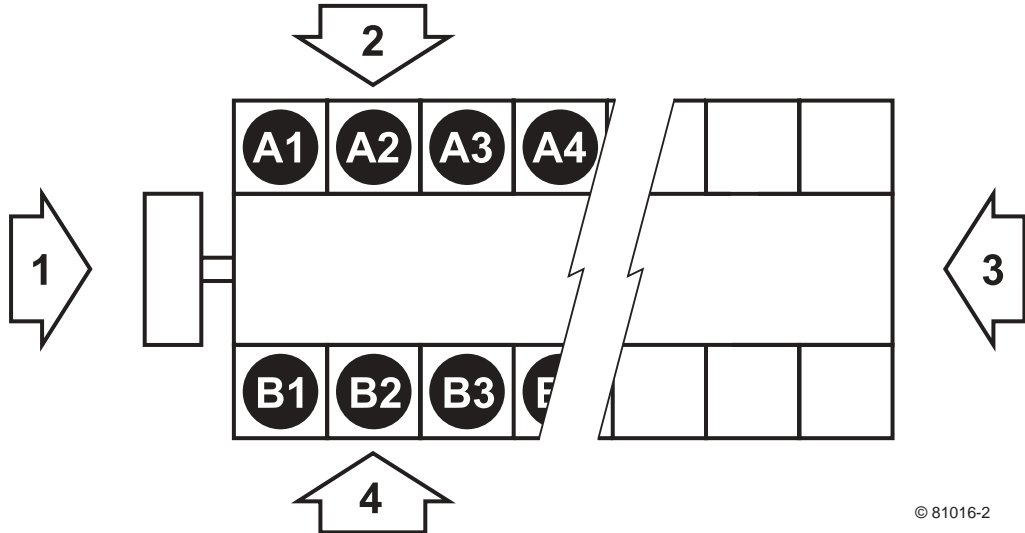

© 81016-2

A 2-4 Designation of the engine sides and cylinders

Engine sides

- | | |
|---------------------|--|
| 1 Drive side | Flywheel, clutch side |
| 2 Left side | Cylinder side A |
| 3 Free side | End, damper, fluid pump, opposite to clutch side |
| 4 Right side | Cylinder side B |

Cylinder numbering

Counted and labelled from the drive side.

Direction of rotation:

Looking towards the drive side: In anticlockwise direction "left-hand rotation"

Engine and unit illustrations

V12 engine

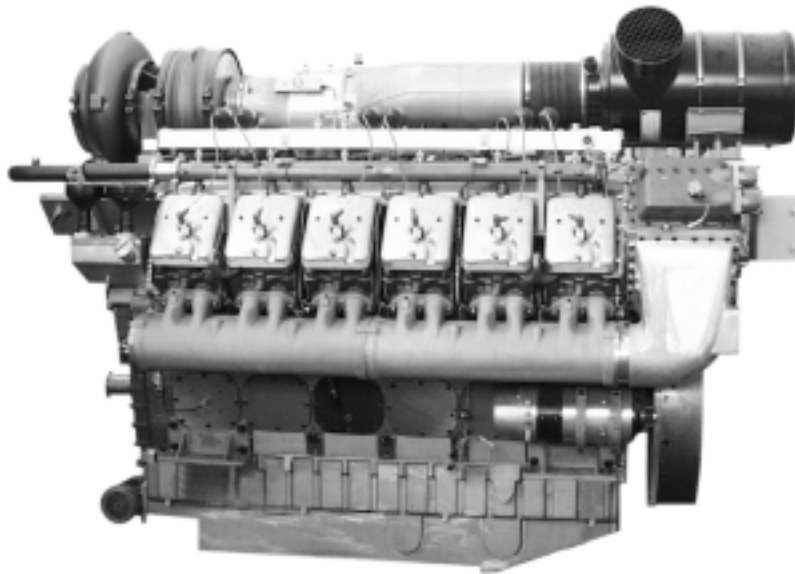

A 2-5 80397-1 V12 engine

V16 engine

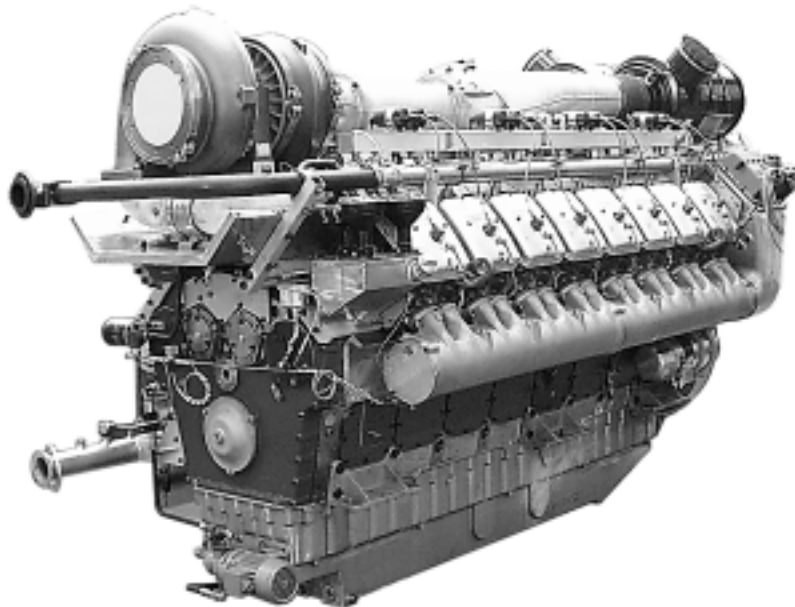

A 2-6 81043-1 V16 engine

V20 engine

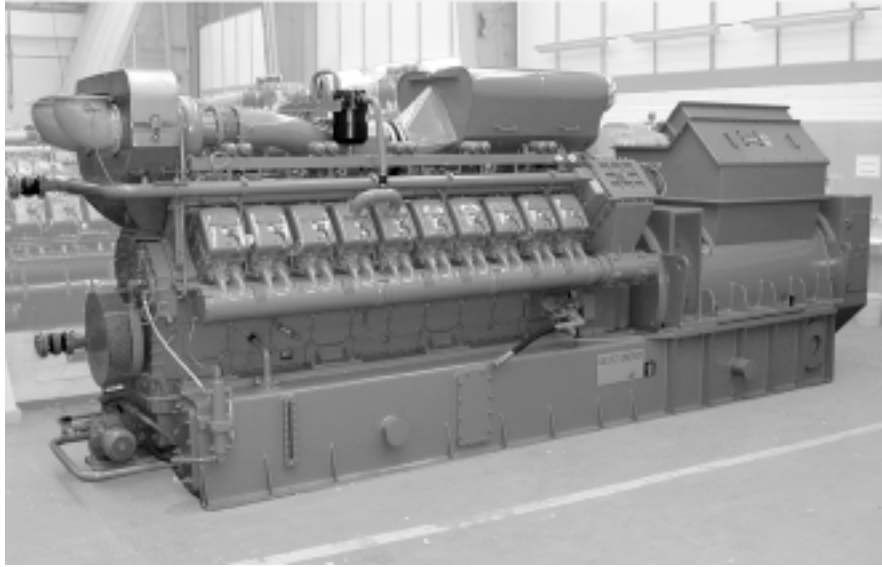

A 2-7 83831-1 V20 engine

V16 engine, left side

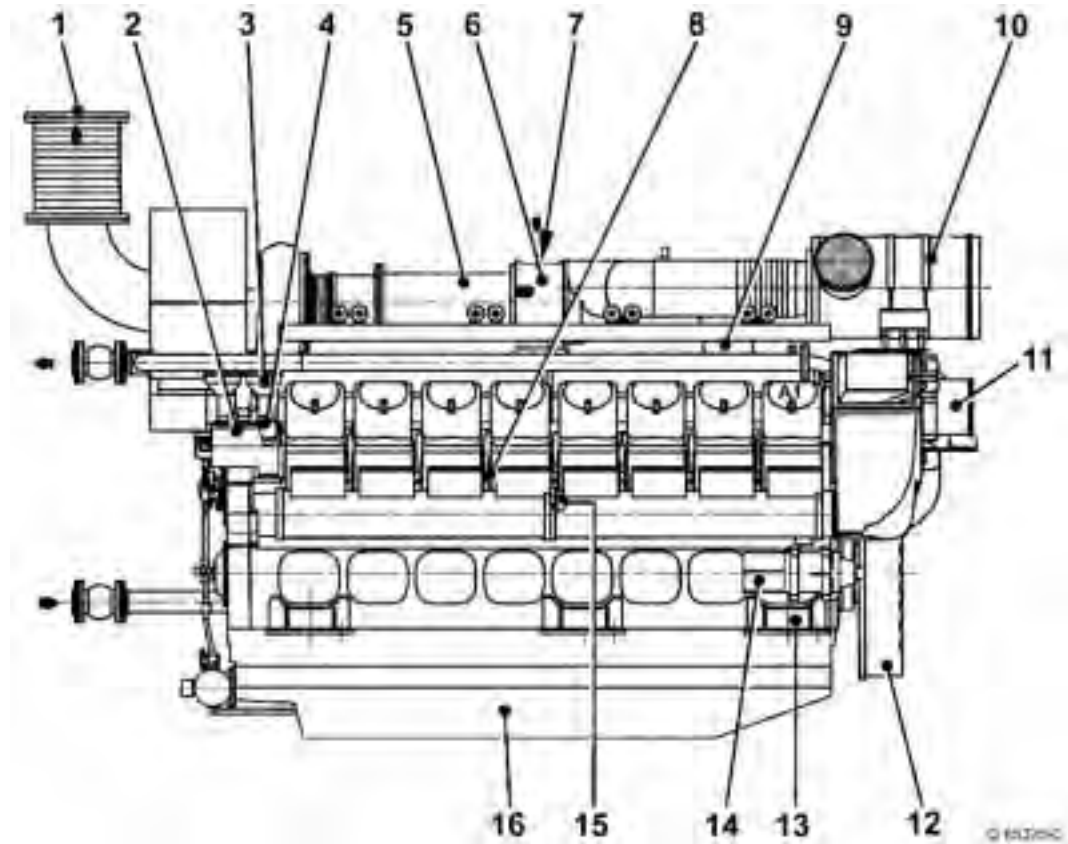

- 1 Exhaust pipe after TC
- 2 Crankcase bleed valve
- 3 Oil separator
- 4 Oil filler neck
- 5 Gas mixing pipe
- 6 Mixer valve
- 7 Gas inlet gas mixer valve
- 8 Oil dipstick
- 9 Speed governor
- 10 Air filter
- 11 Ignition system
- 12 Flywheel
- 13 Engine mounting
- 14 Starter
- 15 Engine centre of gravity
- 16 Oil pan

V16 engine, drive side

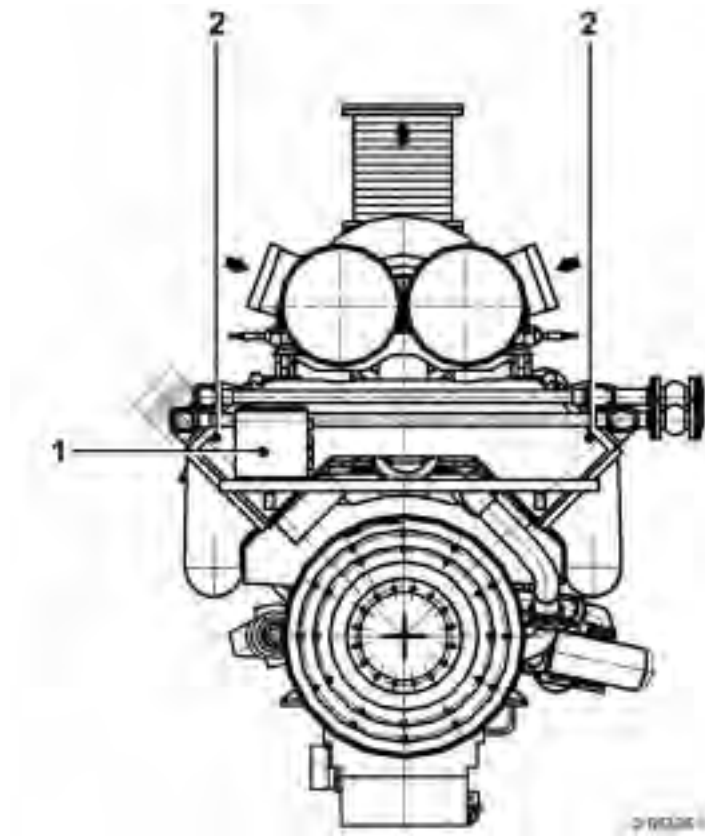

A 2-8

- 1 Ignition system
- 2 Intercooler

V16 engine, right side

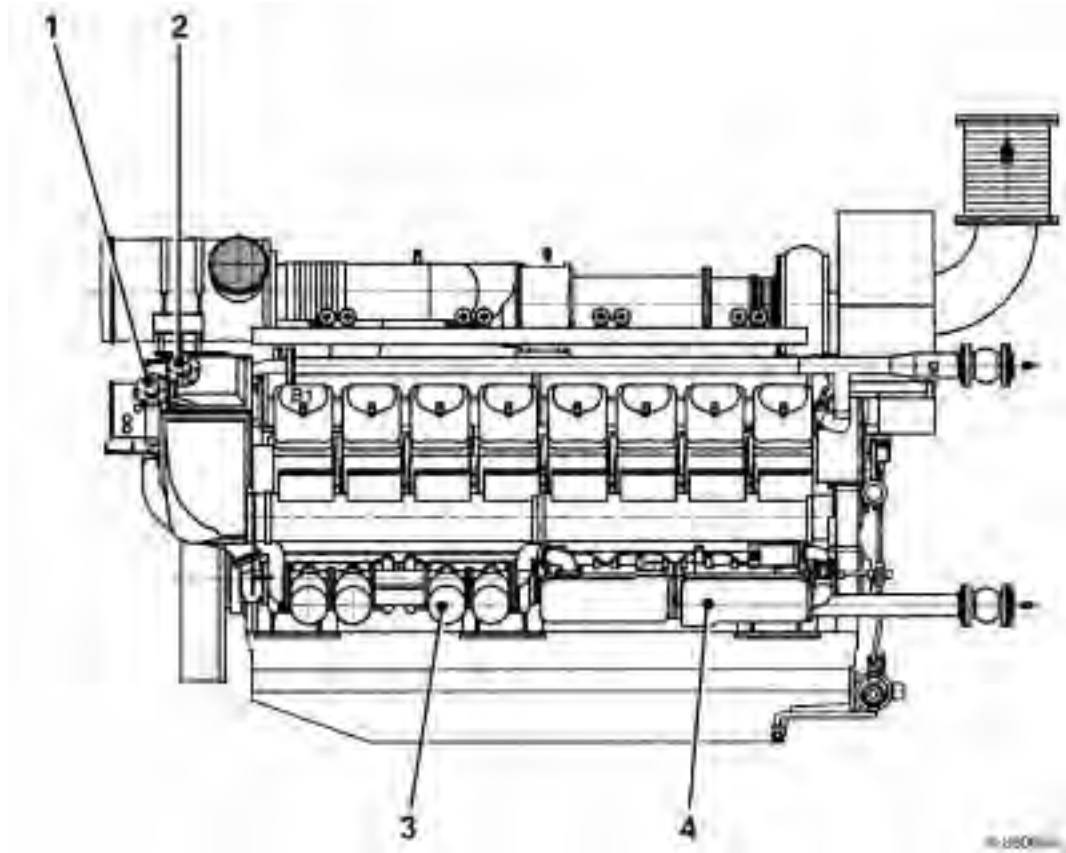

A 2-9

- 1 Feed to intercooler (low temperature circuit)
- 2 Flow from intercooler (low temperature circuit)
- 3 Lube oil filter
- 4 Lube oil cooler

V16 engine, free side

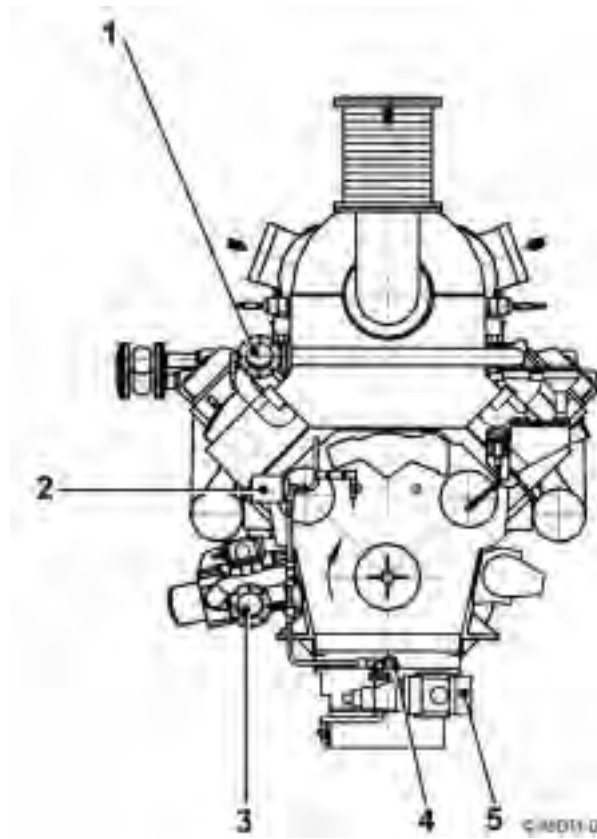

A 2-10

- 1 Coolant drain
- 2 Lube oil filter
- 3 Coolant feed
- 4 Pressure pipe from pre-lube pump
- 5 Pre-lube pump electric

V16 engine, top

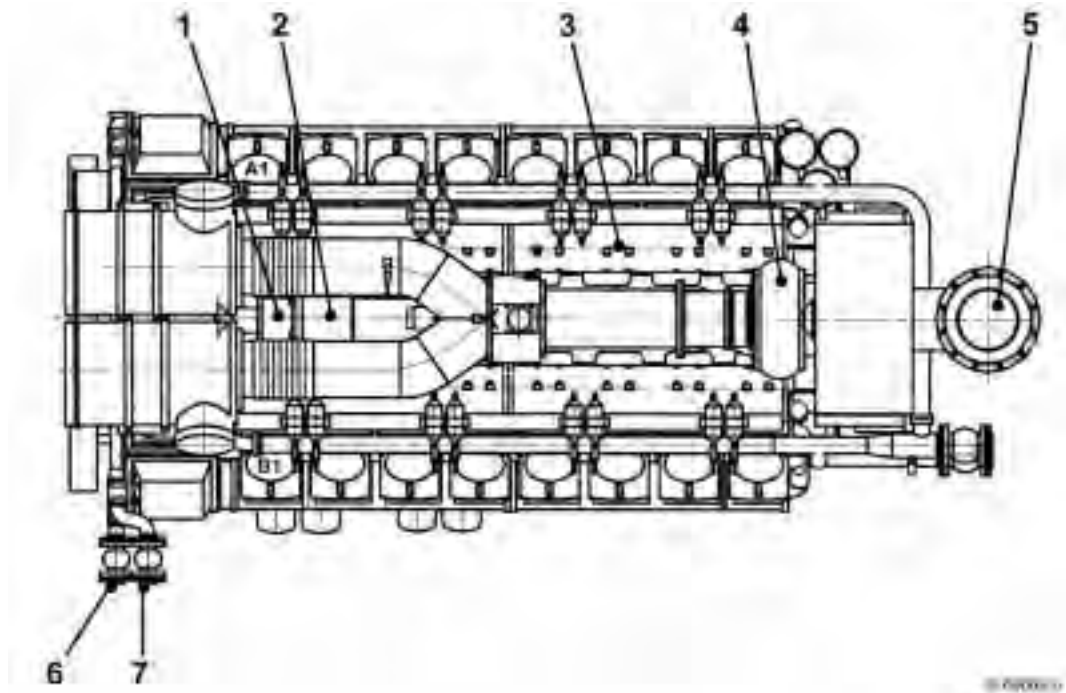

- 1 Gas throttle
- 2 Speed governor
- 3 Exhaust manifold (A-side)
- 4 Turbocharger
- 5 Exhaust pipe after TC
- 6 Feed to intercooler (low temperature circuit)
- 7 Flow from intercooler (low temperature circuit)

Design and function

Cylinder head

The cylinder heads are made from a special alloyed casting like the crankcase. One single cylinder head is installed per cylinder. Thanks to the excellent access and optimized design, the single cylinder head can be replaced in a very short time.

The cylinder heads are liquid-cooled and integrated into the engine cooling system.

The cylinder heads are multi-valve heads, i.e. two inlet valves per cylinder ensure optimum filling and two outlet valves for fast exhaust discharge. The high heat-proof valves are located in the pressed-in and therefore easily replaceable valve seat rings. The valves are controlled by a proven valve bridge technique. The valve bridge control operates with particularly low wear and is very maintenance-friendly.

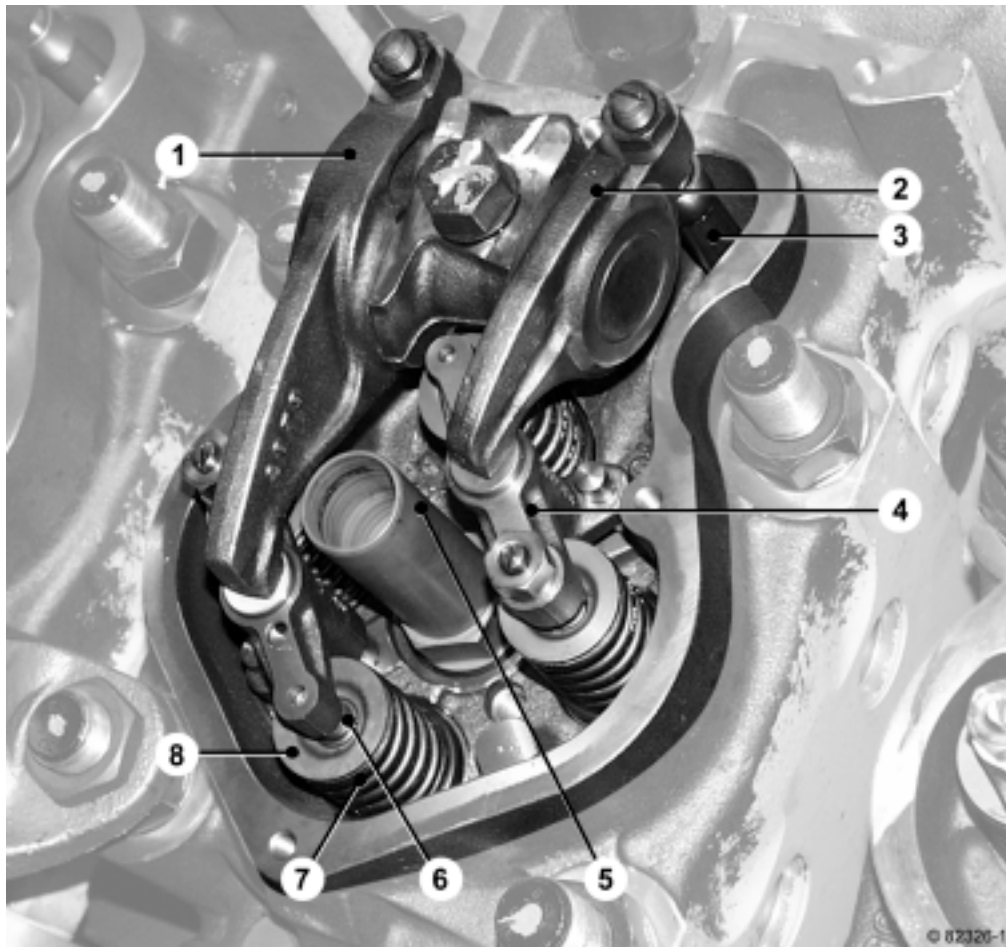

A 2-11 Cylinder head

- 1 Rocker arm (inlet)
- 2 Rocker arm (outlet)
- 3 Stop rod
- 4 Valve bridge
- 5 Spark-plug shaft
- 6 Valve
- 7 Valve spring
- 8 Valve head

Channel guide

The channel guide is based on the cross current principle. The cylinder heads are supplied with the combustion gas through the charge mixture pipe from the one side. The two inlet channels 2 and 3 have different manifolds in the cylinder heads. They are divided into a filling channel 2 and a twist channel 3. These ensure, by their shape, a combustion gas flow into the combustion chamber which greatly improves the filling. The outlet channels 1 end in the exhaust system in which the exhaust gas energy is not lost but recycled.

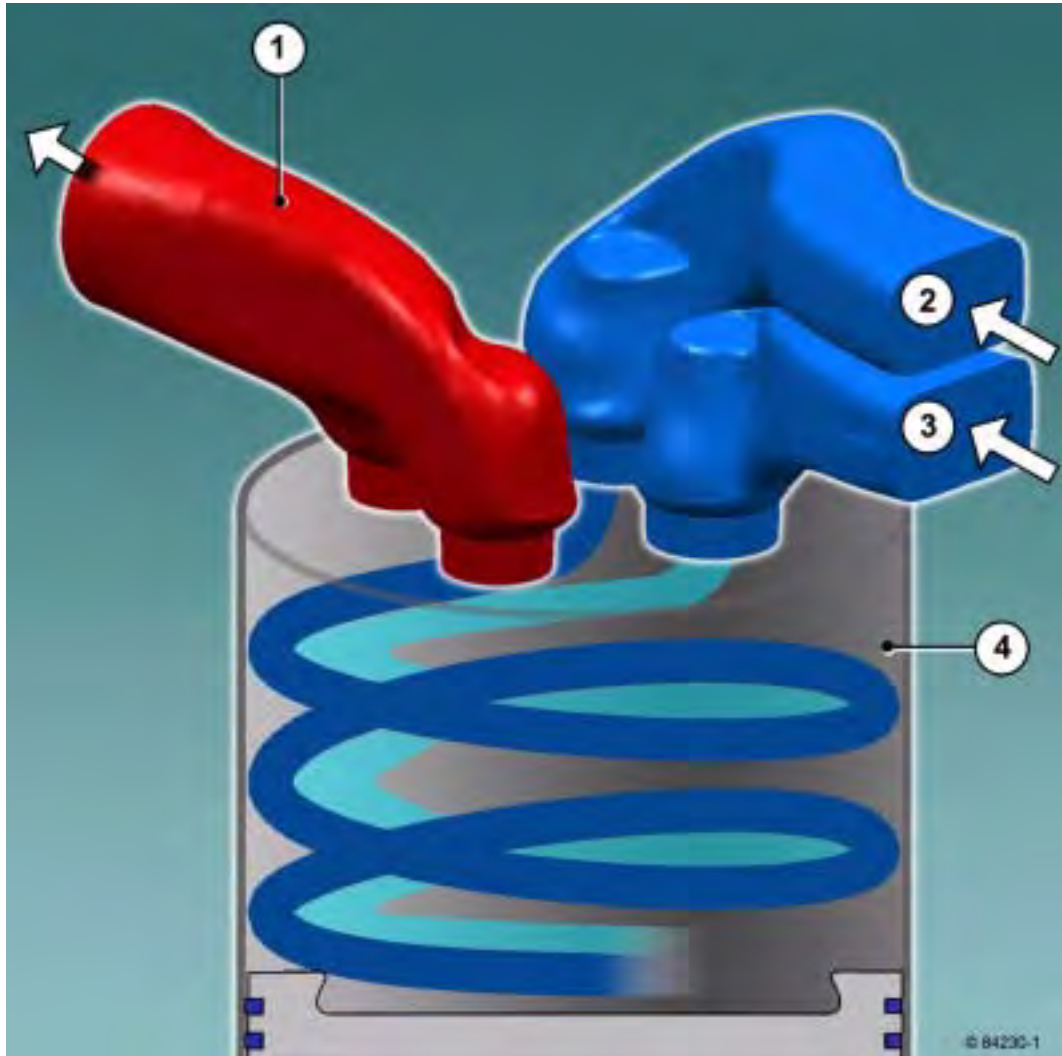

A 2-12 Channel guide

Drive system

The machined crankshaft with bolted on counterweights is suspended in the crankcase. The bearing covers are held vertically by two studs and are fastened horizontally by two additional screws for cross bracing. The engine has forged light metal pistons which are cooled by lube-oil injection nozzles and double T-shank con-rods. The lube oil supply to the main bearing and con-rod bearing is provided by a lube oil pump which sucks the lube oil from the oil pan.

Crankcase

The crankcase is made of a specially alloyed casting. Torsional strength, breaking strain and casting tightness which enables a low weight and compactness distinguish this manufacturing method. The side walls of the crankcase are pulled down to below the center of the crankshaft and therefore guarantee additional torsional strength. The small cylinder enable a narrow design which is required in many applications.

Engine control and wheel drive



A 2-13 Wheel drive

- 1 Toothed wheel crankshaft (59 teeth)
- 2 Intermediate wheel (59 teeth)
- 3 Intermediate wheel (33 teeth)
- 4 Camshaft toothed wheel, B-side (66 teeth)
- 5 Camshaft toothed wheel, A-side (66 teeth)
- 6 Intermediate wheel to the lube oil pump (52 teeth)
- 7 Toothed wheel lube oil pump drive (40 teeth)

Speed control

The speed controller controls the performance of the engine by adjusting the throttle valve position. This control takes place electronically via the TEM system. During electronic speed control the actual speed is picked up by a magnetic pulse sensor (pickup). The pick-up signal is transferred to the TEM system and compared with the reference speed. In case of deviations, the actuator is controlled by the TEM system. The actuator is connected with the throttle valve and can adjust it.

In the V12 and V16 engines the actuator is connected to the throttle by the regulating lever and a linkage.

The V20 engine is equipped with two actuators whose output shafts act directly on the rotary disk valves.

Actuator

The V12 and V16 engines are equipped with the actuator StG 30, two actuators StG 2080 are fitted to the V20 engine.

The actuators are distinguished by:

- high adjustment forces acting in both directions
- low power consumption
- Insensitivity at slow voltage change in the power supply, sudden changes lead to controller faults.

V12 and V16 engine with StG 30

A DC motor transfers the torque to the controller output shaft via intermediate gearing. Setting of the controller output shaft is achieved by the return probe, which carries out non-contact sampling of the return cams and passes the information to the TEM system.

On reaching the stop, current limitation is implemented after approx. 20 seconds, which reduces the actuator current to such an extent that no damage is suffered by the actuator.

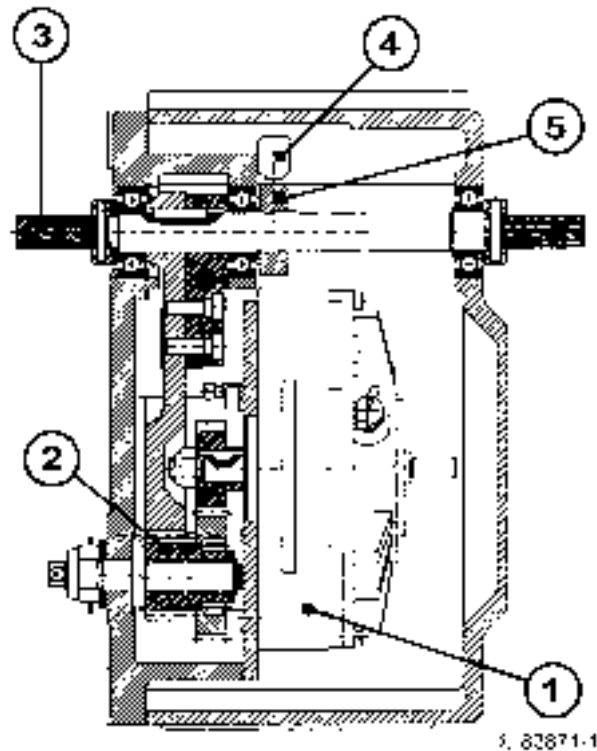

A 2-14 Actuator, Heinzmann StG 30

- 1 DC motor
- 2 Gearbox
- 3 Output shaft
- 4 Probe
- 5 Return cams

V20 engine with StG 2080

On the shaft of the actuator is a multi-pole permanent magnet. Opposite the permanent magnet is a coil body on which a working coil is mounted. If the working coils conduct, torque occurs in one direction, the reversal of the current provides torque in the opposite direction.

A return spring is attached to the controller output shaft, the force of which is normally sufficient to pull the actuator to the stop position in the event of a power failure. Setting of the controller output shaft is achieved by the return probe, which carries out non-contact sampling of the return cams and passes the information to the TEM system.

On reaching the stop, current limitation is implemented after approx. 20 seconds, which reduces the actuator current to such an extent that no damage is suffered by the actuator.

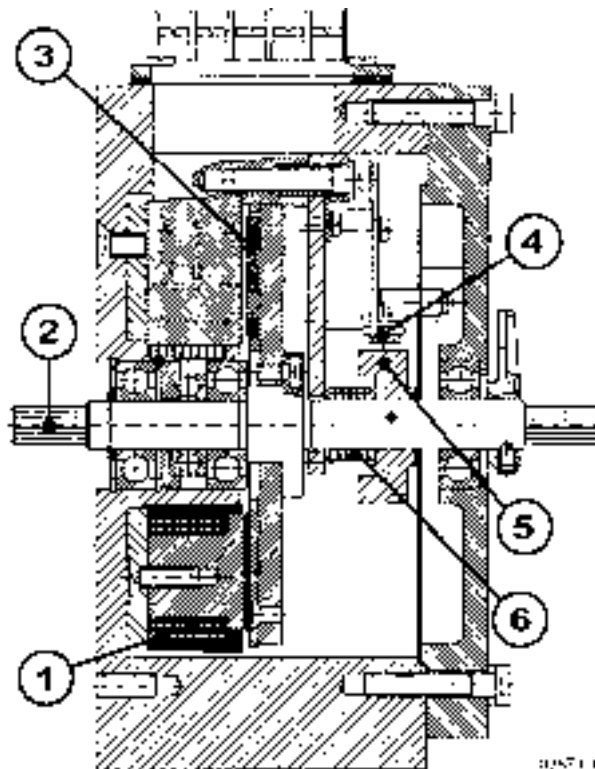

A 2-15 Actuator, Heinzmann StG 2080

- 1 Working coil
- 2 Output shaft
- 3 Permanent magnet
- 4 Probe
- 5 Return cams
- 6 Return spring

Installation location

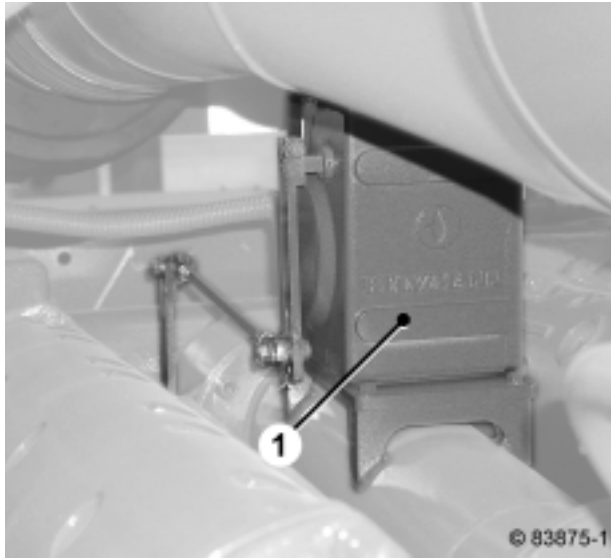

A 2-16 Actuator StG 30; V12 and V16 engine

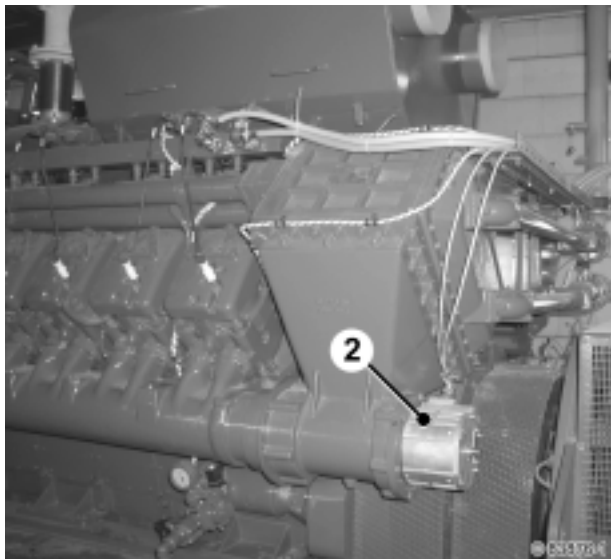

A 2-17 Actuator StG 2080; V20 engine

Charging

The engine is equipped with a turbocharger and a liquid-cooled mixture cooler. The engine achieves a higher performance with simultaneous reduction of the pollutant emissions due to the mixture charging.

Schematic diagram of turbocharging

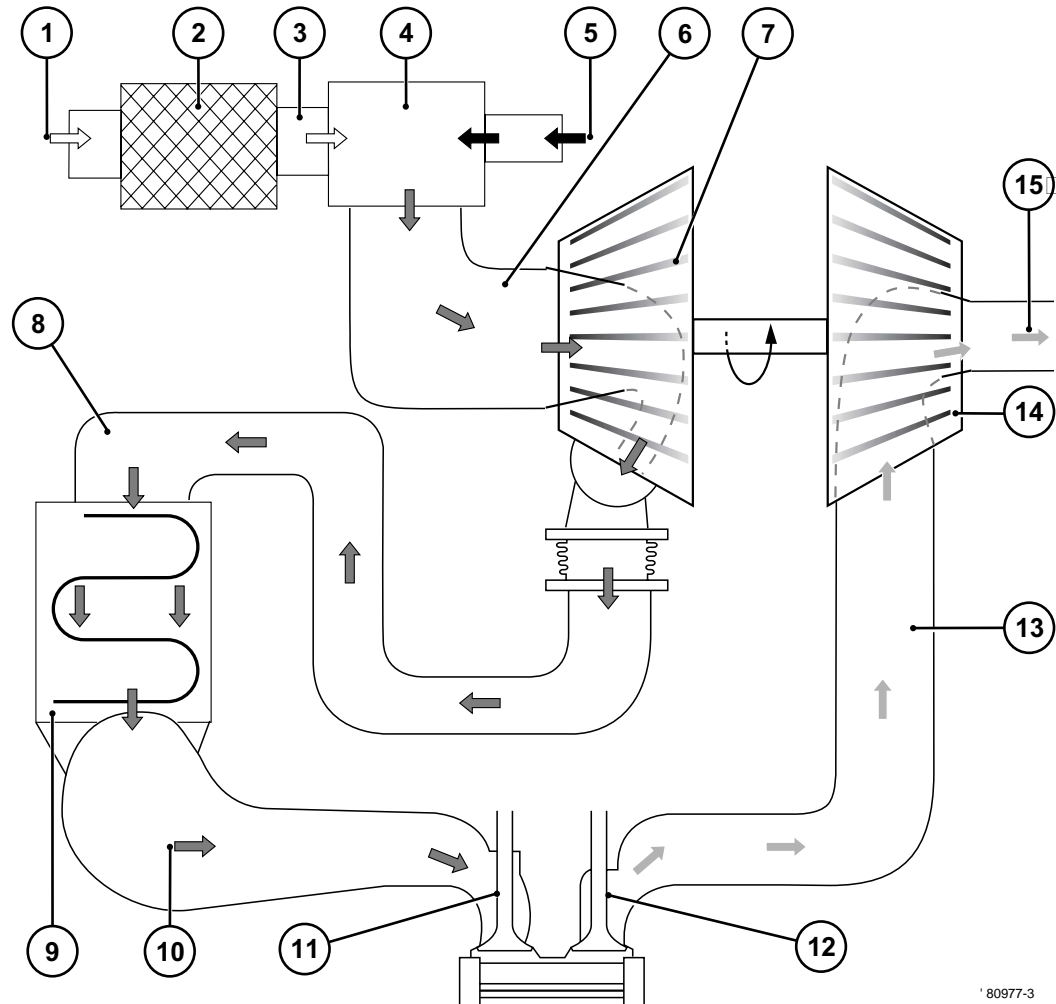

A 2-18 Charging schematic

' 80977-3

- | | | | |
|---|-----------------------------------|----|----------------------------|
| 1 | Intake air | 9 | Mixture cooler |
| 2 | Air filter | 10 | Cooled mixture |
| 3 | Filtered air | 11 | Inlet valve |
| 4 | Gas / air carburettor | 12 | Outlet valve |
| 5 | Gas | 13 | To the exhaust gas turbine |
| 6 | Mixture to the compressor | 14 | Turbine wheel |
| 7 | Compressor wheel | 15 | To the silencer |
| 8 | From compressor to mixture cooler | | |

Compressor bypass

When adapting the turbocharger, the combustion behaviour of the gas (energy content, combustion speed etc.) must be taken into account. Methane or sewage gas may vary greatly in composition. This results in great changes in the combustion behaviour. At decreasing heat value and high inert gas content the combustion speed is reduced which leads to a higher exhaust gas temperature. This on the other hand leads to a higher charging pressure at the same performance and the compressor of the turbocharger begins "pumping". An adjustable compressor bypass on the turbocharger avoids the need for another turbocharger specification according to the gas composition. An optimum adaptation to the existing gas quality is possible at any time without conversions. For two-gas operation, i.e. alternative operation with natural gas or dump/sewage gas, the compressor bypass with solenoid valve is provided. The turbocharger is optimized for the natural gas operation (solenoid valve closed). For operation with methane/sewage gas the bypass is released by opening the solenoid valve. Additionally a setting option for adapting to the dump gas quality is available. The bypass is set in commissioning and when required (e.g. very great variation in the gas quality at dumps) by DEUTZ service personnel.

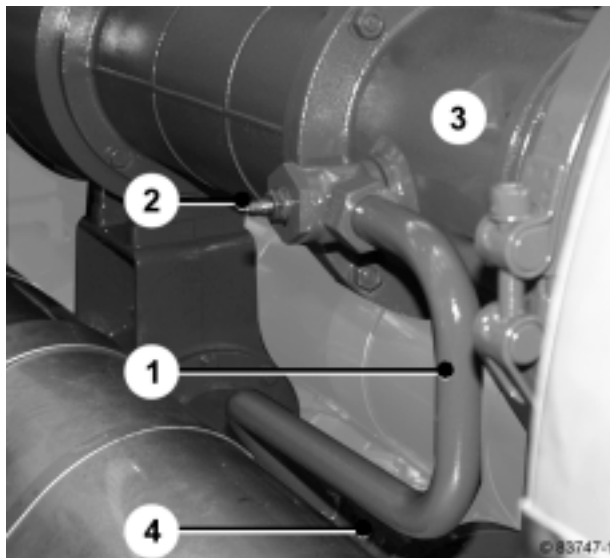

- 1 Bypass pipe
- 2 Setting screw
- 3 Mixture pipe before turbocharger
- 4 Mixture pipe after turbocharger



A 2-19 Compressor bypass (two-gas operation)

- 1 Bypass pipe
- 2 Setting screw
- 3 Mixture pipe before turbocharger
- 4 Mixture pipe after turbocharger
- 5 Solenoid valve closed: Natural gas operation
open: Sewage/methane gas operation

Gas system

Gas control line

Structure and function (♥ DIN EN 676; DIN 33831, Part 2)

The control and safety systems incorporated in the gas regulator line ensure that the gas engine can be operated safely and reliably. The gas pressure regulator adapts the mains side gas pressure to the requirements of the gas engine.



Improper installation, adjustment, modification, operation or maintenance can cause injury or damage.

Installation, wiring, adjustment and maintenance may only be performed by authorized and qualified personnel.

Read the instructions for installation and use.

The equipment must be installed according to applicable regulations.

The local regulations of electricity and gas boards must be observed.

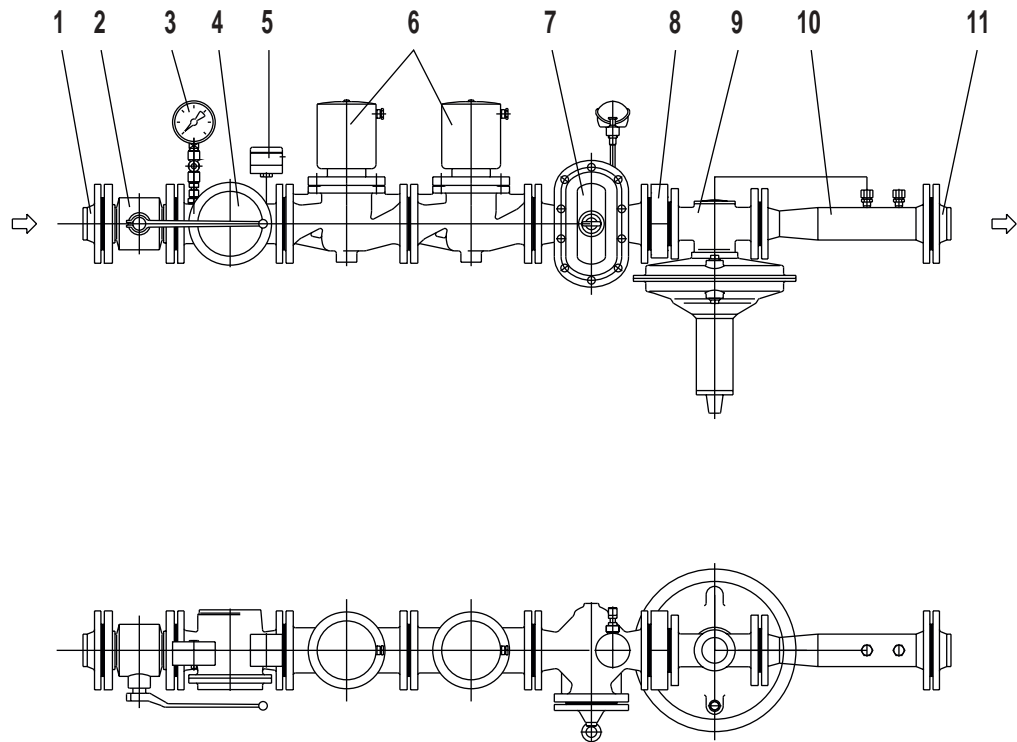

A 2-20 80321-2 Figure Gas regulator line

Components of the gas control system- all DVGW tested!

- 1 Flange
- 2 Shut-off device (ballcock) - hand-operated shut-off of the gas supply for repair work within the gas regulator line and with the unit shut down. When the whole gas control system is disconnected the closed
- 3 pressure gauge with pushbutton tap stays at the control system output for checking the gas pressure
- 4 Gas filter
- 5 Gas pressure gauge (electr. pulse transmitter) - Automatic monitoring of the minimum admissible gas pressure upstream of the gas pressure regulator
- 6 Solenoid valves - with measurement connection
- 7 Flame flashover protection (gas group 2 only)
- 8 Reducer
- 9 Gas pressure regulator - The pressure regulator reduces the gas pressure at the input of the gas regulator line to the gas pressure required in the engine.
- 10 Outlet pipe
- 11 Flange

Automatic shutoff process

To purge the engine when shutting off, the gas supply line must be closed before the ignition is interrupted. This is part of the automatic process carried out by the TEM system.

Assembly and testing

G 600 (DVGW-TRGI), G 490 and G 495 installation regulations apply for the intake up to the customer's on site shut-off device.

The components of the gas regulator line are tested by the manufacturer for strength and leaks. The fully assembled plant must be subjected to a final leak test with air or inert gas with 1.2 times the maximum permissible operating pressure (set output pressure at the regulator) but at least 150 mbar.

- The pressure in the input chamber (mains side) must always be equal to or greater than the pressure in the outlet chamber (engine side).
- Pressure build-up always before the input side, pressure release always before the output side (change pressure slowly!).
- The gas regulator line may only be attached horizontally.
- The gas regulator line must be protected against careless damage, especially if situated low down.
- No vibrations may be transmitted from the engine to the gas pipe.
- The ballcock and pushbutton tap must be operable by hand (max. attachment height 2,100 mm!).
- The pressure gauges must be easy to read.

Instructions for installation

Depending on the gas type, the engine requires the appropriate gas control line.

Nonferrous metals (brass) may not be used for gas-carrying parts when using aggressive gases.

The gas control line must be installed in the same room as the gas engine. This ensures that the gas control line is subjected to the same air pressure conditions as the engine.

Exhaust gas lines must be directed into atmosphere with sufficient cross-section.

Pressure regulators, monitoring devices and pipes must be installed without bracings. Pressure regulators and monitoring devices are always to be fitted according to the manufacturer's instructions. The direction of flow must be followed.

The gas control line must be installed as close to the engine as possible. The distance between the gas control line outlet and the gas mixer inlet must be max. 3 m in length and with max. three 90° curves.

Flame flashovers can occur with fuel gas mixtures whose components may also contain oxygen. The gas control lines contain endurance burning flame flashover protection devices with temperature monitoring to prevent flashovers in the gas-carrying line. For this, a distance of maximum 40 times the pipe diameter of the gas line is permitted between the engine and gas control line. For larger distances, an endurance burning detonation arrester must be provided instead of the flame flashover protection.

Example:	Pipe diameter	= 100 cm
	40 x 100 cm	= 4000 cm
	max. permissible distance	= 4 m

Gas / air mixer, mixture formation

The gas and air are blended to form a combustible mixture in the carburettor immediately upstream of the turbocharger.

The carburettor is in the form of a Venturi tube, i.e. a pipe with a converging section to channel flow which gradually diverges again. The design means that the flow has only a minimum pressure drop and therefore only minimum filling losses in the cylinders. The highest flow rate occurs at the most constricted section. The gas is mixed with the core flow radially from outside at this location via an annular gap using the resulting vacuum. This mixing mode has the advantage that the volume ratio of gas to air remains almost constant even in the case of great fluctuations in the sucked mixture and deviates only slightly from the so-called lambda window in which the safe and cost-effective operating range of the engine is contained.

The adjustable gas gap is used to set the gas-air mixture. The mixture volume is regulated by means of the throttle.

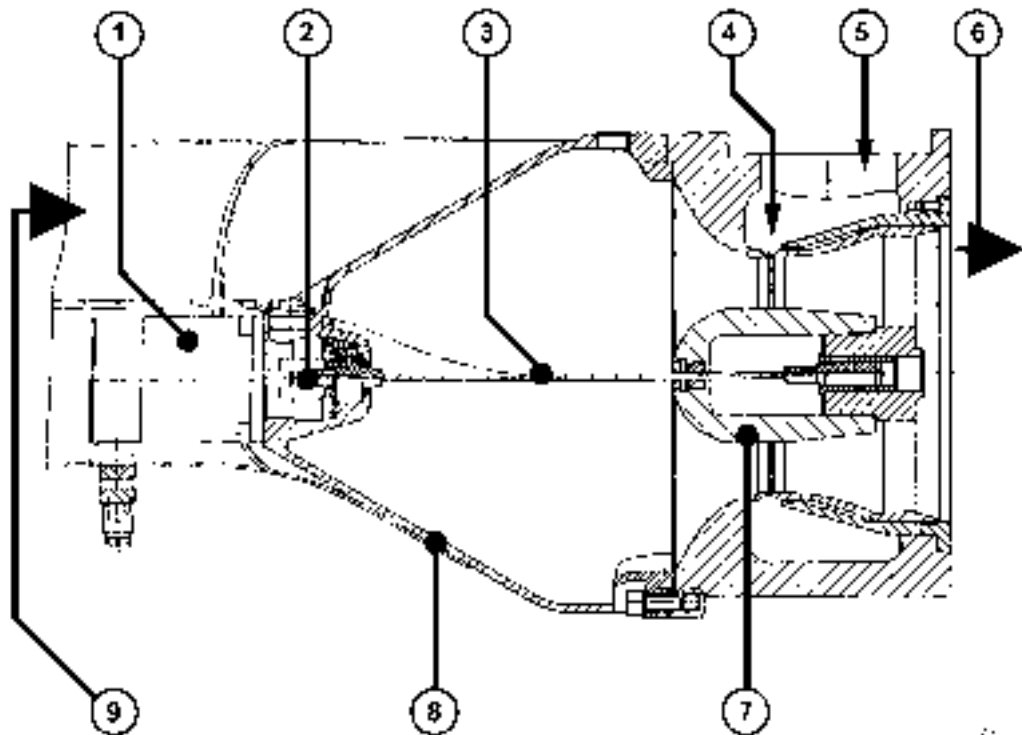

A 2-21 Schematic multi-gas mixer

- 1 Servomotor
- 2 Coupling
- 3 Adjustment spindle
- 4 Adjustable gas gap
- 5 Gas inlet
- 6 Fuel-air mixture
- 7 Venturi nozzle
- 8 Air line
- 9 Air from filter

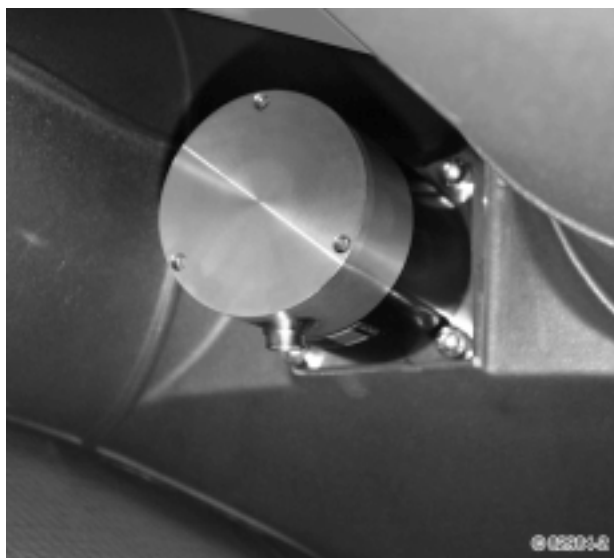

A 2-22 Servomotor

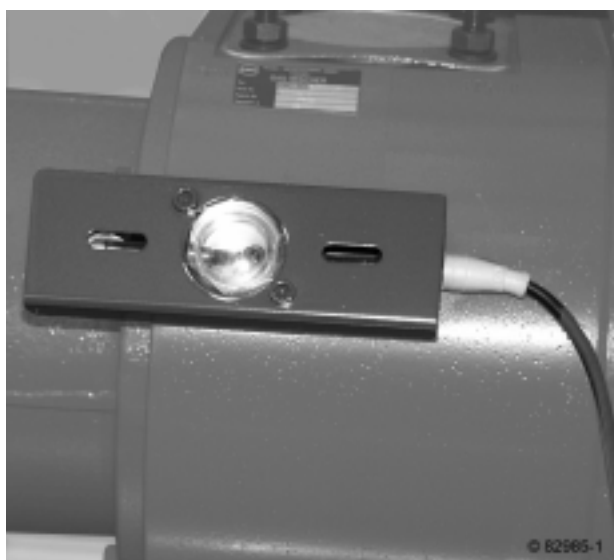

A 2-23 Proximity switch, lean mixture

Lube oil system

The lube oil reduces friction of the components which rub against each other and dissipates heat from the rubbing positions, the piston head and the turbocharger. A film of lube oil on the cylinder surfaces reduces the gliding friction of the piston and piston rings. The lube oil also captures impurities within a suspension and transports them to the lube oil filter. The lube oil pump sucks the lube oil from the oil tray, feeds it through the lube oil cooler and the lube oil filter into the lube oil circuit of the engine. The lube oil pressure in the engine circuit is set by a lube oil pressure regulating valve. The bypass valve is installed to avoid the flow of lube oil being interrupted when the lube oil filter is dirty. If the lube oil pressure gets so high that the lube oil pump is at risk, the safety valve opens and allows the excess lube oil to flow back into the oil tray.

Lube oil level switch

The engine is equipped with a lube oil level switch. It transfers various information about the lube oil level in the engine to the TEM system.

The lube oil refilling process therefore runs fully automatically through the TEM system. If there should still be a lack of oil, the engine is shut down by the TEM system.

The lube oil change is also automated by the lube oil level switch in connection with the TEM system. The lube oil level switch reports the different oil levels (oil tray empty or full) to the TEM system which then switches the pre-lube pump on or off accordingly.

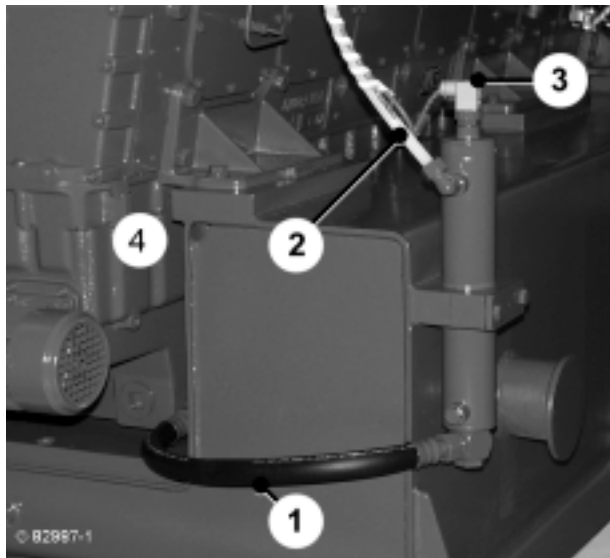

A 2-24 Lube oil level switch

- 1 Connecting line to the oil pan
- 2 Vent line
- 3 Connector
- 4 Oil pan

Crankcase bleed valve

Model AS 500 - Dynapure

The crankcase bleed valve is equipped with an oil mist trap. The sucked in air/oil mixture is spun and accelerated in the oil mist trap by a rotating drum so strongly that the micro-fine oil mist particles form small droplets and are separated from the air in the rotating filter drum by the sieving and inertia effect. The oil gained in this way flows back into the oil pan through the drain.

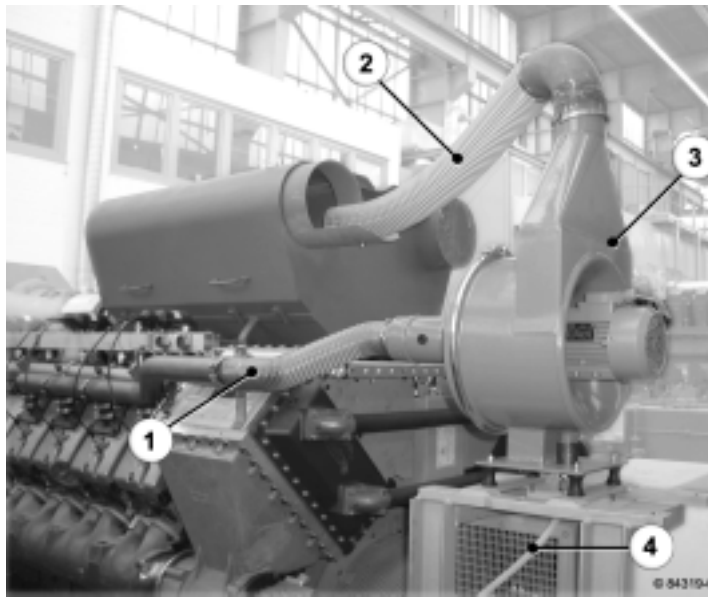

A 2-25 Crankcase bleed valve

- | | | | |
|---|-----------------------------------|---|---------------|
| 1 | Intake pipe | 3 | Oil mist trap |
| 2 | Air return line to the air filter | 4 | Drain line |

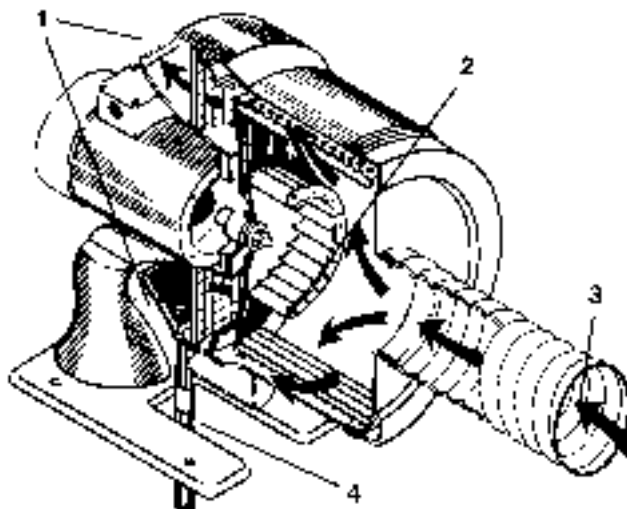

A 2-26 Schematic oil mist trap

- | | |
|---|---|
| 1 | Air outlet, the cleaned air is returned |
| 2 | rotating filter drum with turbo wheel |
| 3 | Intake elbow |
| 4 | Drain for trapped oil |

Cooling system

The chemical energy in the gas is converted into heat energy during combustion. The engine can only partly convert this into mechanical energy. The remaining heat is dissipated mainly with the exhaust gas and the coolant.

The engine has a two circuit cooling system. The lube oil cooler, mixture cooler, water-cooled exhaust pipe and cylinder cooler are integrated in the engine cooling circuit. The low temperature mixture cooler is cooled by a separate cooling circuit. In this way it is possible to reduce the mixture temperature and increase the engine performance. The coolant temperature is controlled and monitored automatically. The engine is switched off by the TEM system at temperatures above the set maximum values.

Compressed air system

Compressed air starter

The V20 engine is equipped with a compressed air starter or an electric starter depending on the version.

The compressed air starter generates a sufficiently high starting speed for ignition through the flywheel.

Triggered by the TEM system control air presses the starter pinion into the flywheel ring gear, the operating air then rotates the engine up to starting speed. When the engine has fired, the TEM system tracks out the starter and blocks further starts when the machine is running.

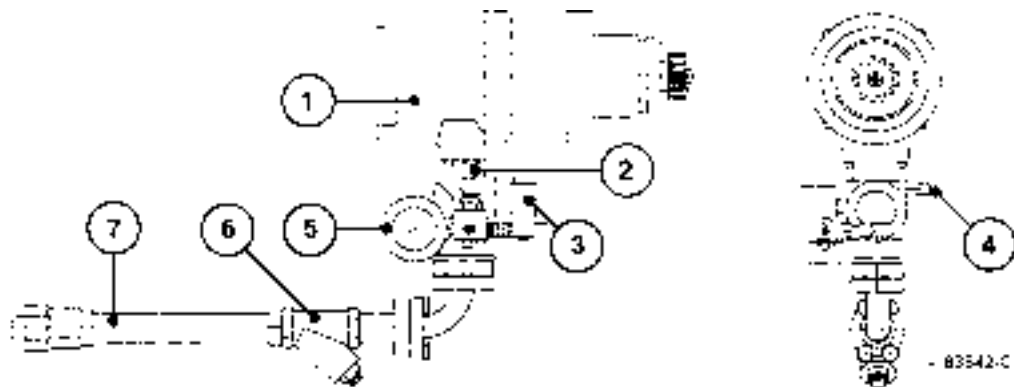

A 2-27 83843-0 Schematic diagram compressed air starter with air control system

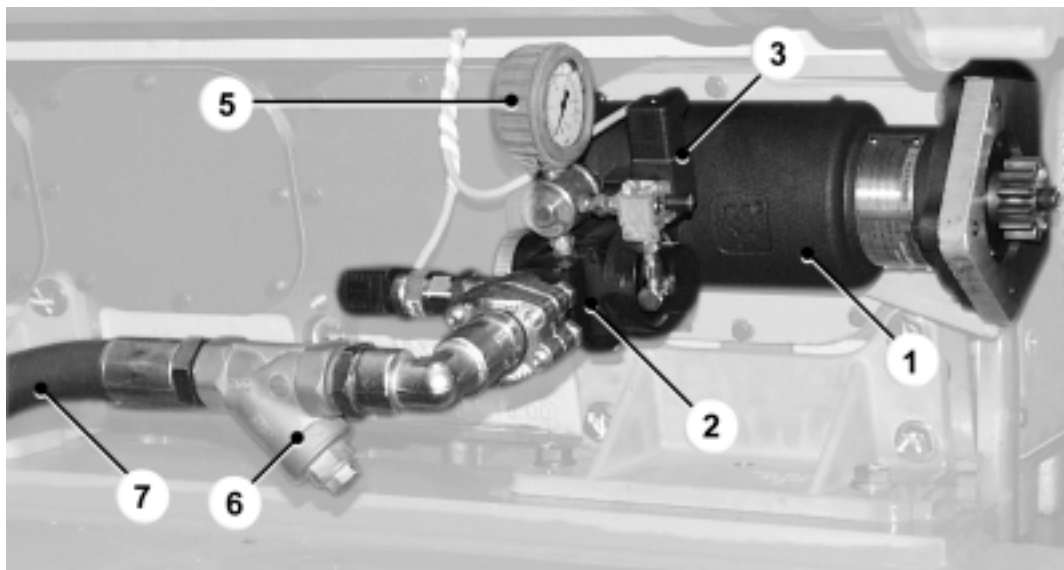

A 2-28 83843-1 Compressed air starter with air control system

- 1 Compressed air starter
- 2 Pressure reducing starter valve - Input pressure: max. 30 bar
- backpressure : 1...10 bar
- 3 Solenoid valve 24V
- 4 Safety valve - Pressure setting: 12 bar
- 5 Pressure gauge
- 6 Dirt trap
- 7 High-pressure hose (air supply)

Electrical system

Ignition system

The engine is equipped with a TEM-ZS3 microprocessor-controlled ignition system which is supplied by the TEM system with a voltage of 24 V. A toothed gear on the flywheel is scanned by an electronic sensor and enables the exact crank angle time to be determined. The right process phase for the ignition spark in the four-stroke technique is selected by an additional sensor on the camshaft. The electronic control device sends medium voltage pulses to the ignition coils assigned to every cylinder. From there a high voltage cable leads to each spark plug. An extremely fast voltage rise guarantees a powerful and short ignition spark with a gentle effect on the spark plug electrodes. Settings on the ignition device are made exclusively by DEUTZ service personnel. Some examples are adjustment of the ignition time to adapt to the gas quality, or the selection of two different ignition times in two-gas operation. For work on the ignition system such as changing parts, e.g. spark plugs, ignition cables and ignition coils, the ignition no longer needs to be switched off because the TEM system has switched off the ignition safely when at a standstill.



A 2-29 Ignition system

Electrical starter

The engine is equipped with an electrical starter. The starter accelerates the engine crankshaft to ignition speed.

An electric motor is fitted to the flywheel housing which drives the flywheel via the starter pinion.

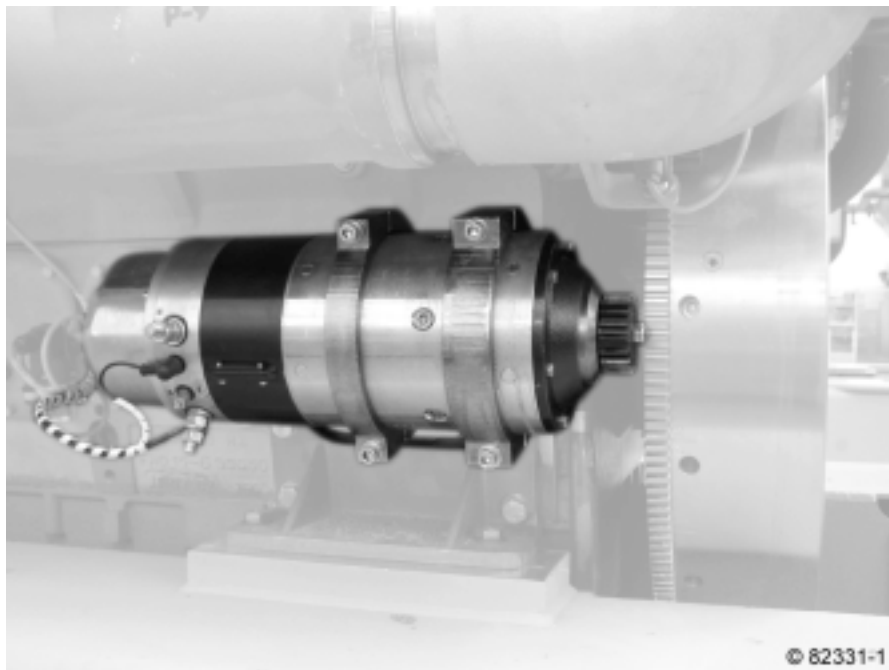

A 2-30 Electrical starter

Terminal assignment plans TEM Evolution

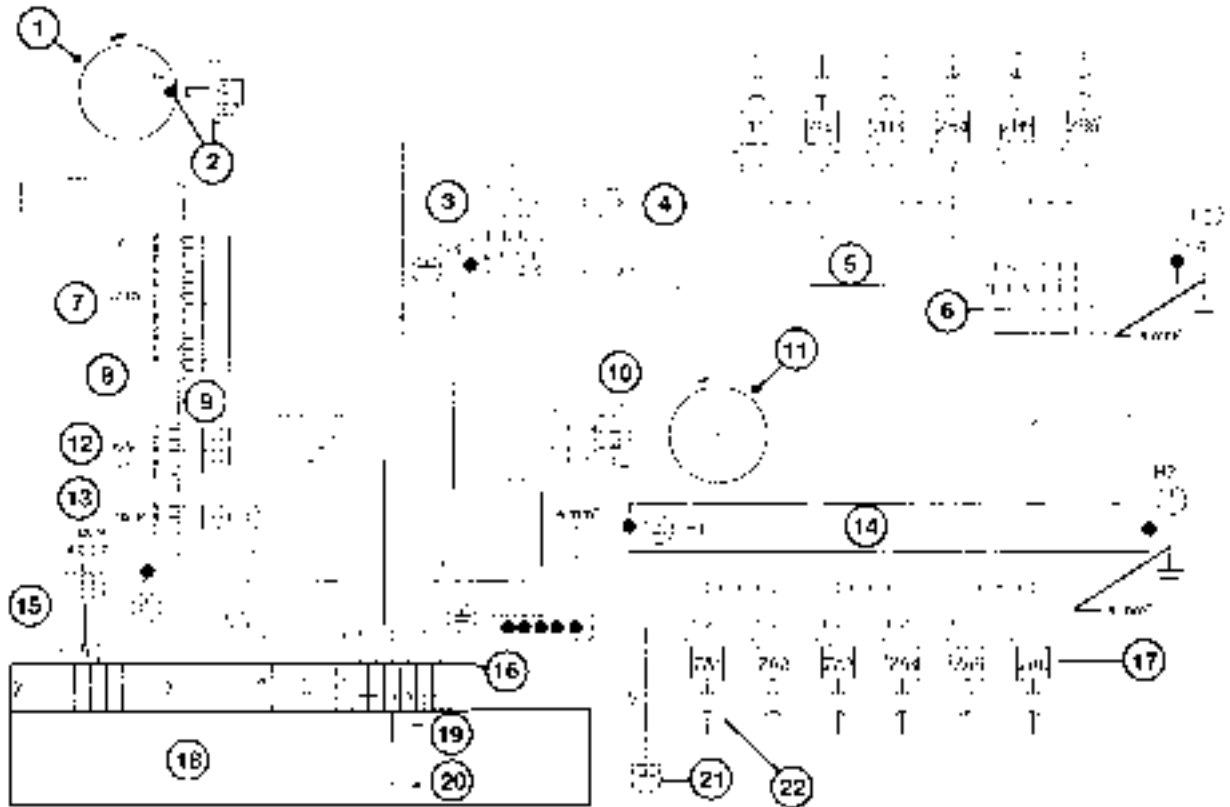

A 2-31 Terminal assignment plan TEM Evolution (V12 engine)

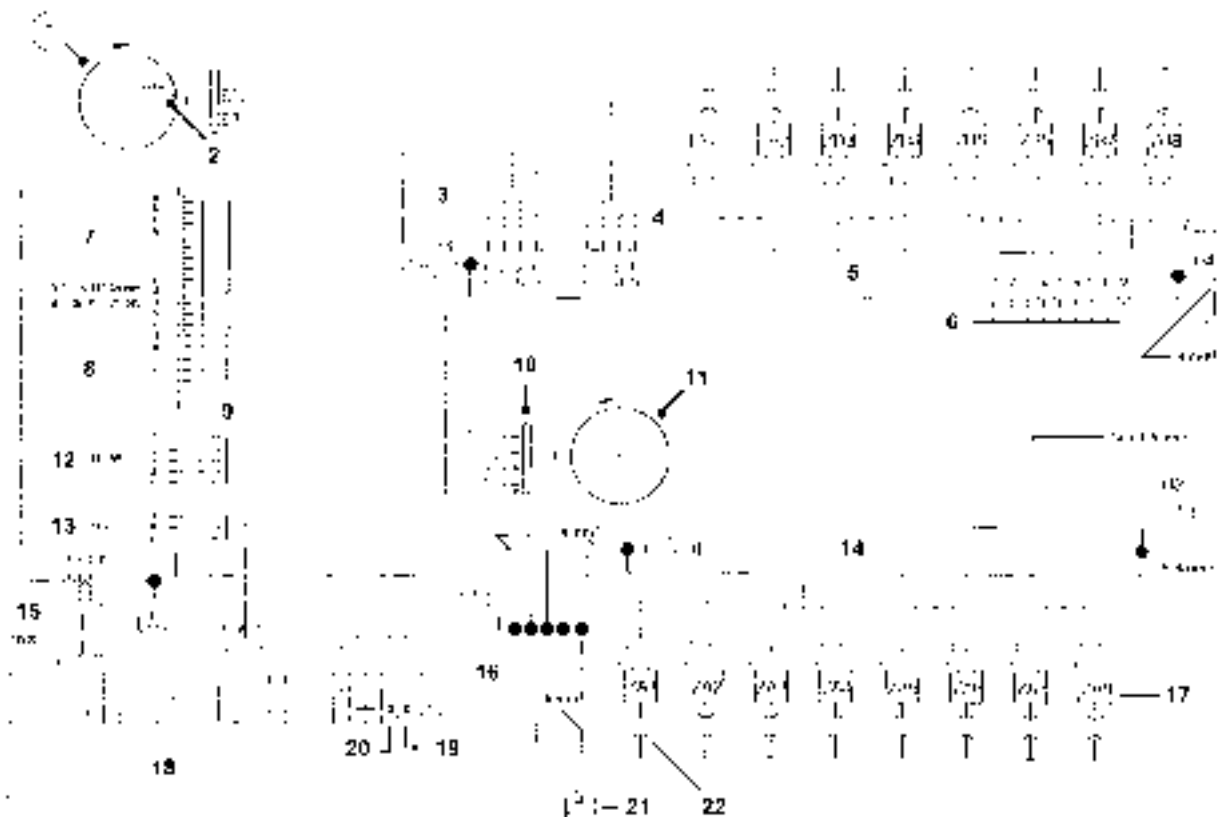

A 2-32 Terminal assignment plan TEM Evolution (V16 engine)

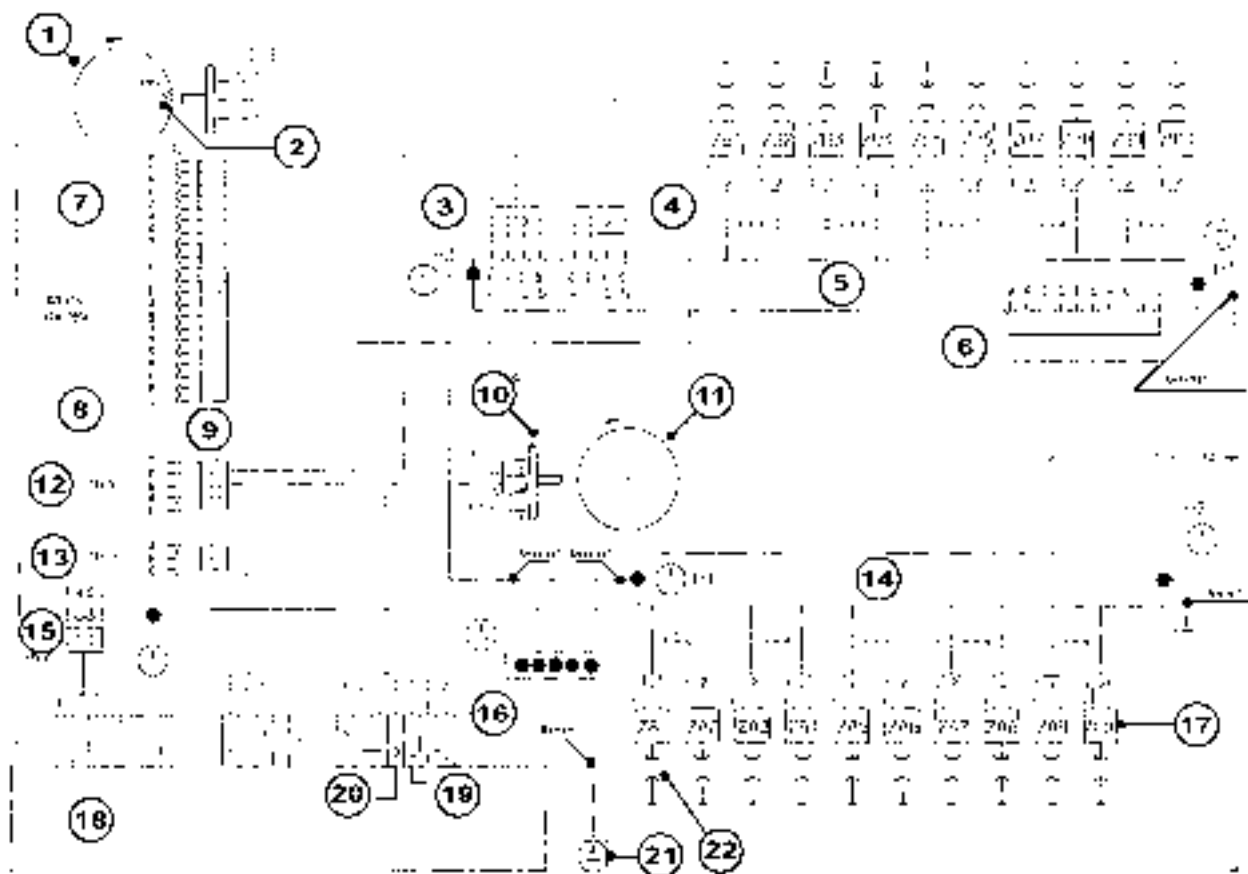

A 2-33 Terminal assignment plan TEM Evolution (V20 engine)

- 1 Direction of rotation of camshaft
- 2 Pickup index camshaft toothed wheel
- 3 Connector O
- 4 Connector M
- 5 Multi-function rail cylinder row B
- 6 Plug F
- 7 Plug
- 8 Ignition system TEM-ZS3
- 9 Plug P1
- 10 Pickup on the flywheel
- 11 Direction of rotation of flywheel
- 12 Plug
- 13 Plug
- 14 Multi-function rail cylinder row A
- 15 Plug
- 16 Ground point on the crankcase
- 17 Ignition coils
- 18 TEM Evolution
- 19 Ring gear crankshaft
- 20 Camshaft
- 21 Earthing of the switching system
- 22 Spark plug

Electrical components

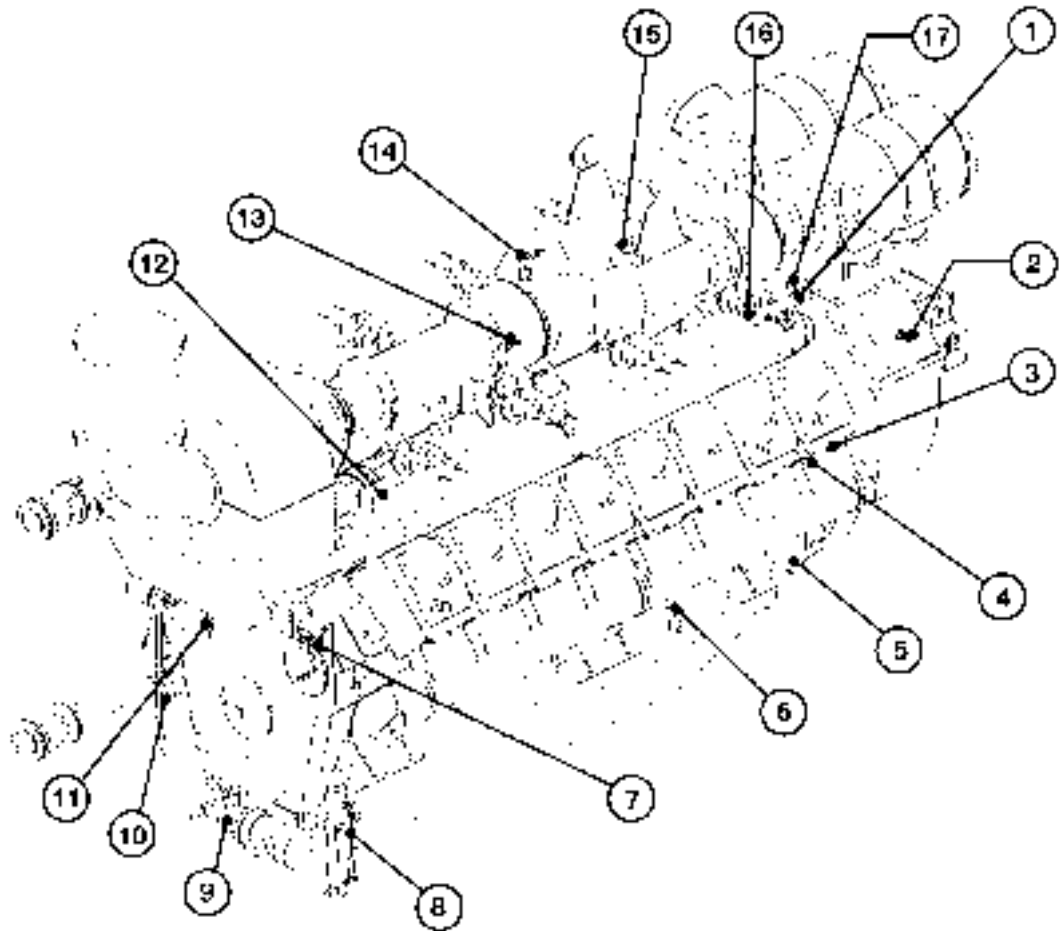

A 2-34 Electrical components (example V16 engine)

- 1 Plug C
- 2 Coolant temperature sensor before intercooler (202)
- 3 Knocking sensor (241...246)
- 4 Thermocouple (461...466)
- 5 Starter (7.5.1)
- 6 Starter relay VK1
- 7 Crankcase - overpressure (145)
- 8 Lube oil level (234)
- 9 Electric motor for pre-lube pump (2.5.1)
- 10 Lube oil pressure switch (196)
- 11 Camshaft pickup (319)
- 12 Multi-function rail (cylinder row A)
- 13 Inductive proximity switch (159)
- 14 Sensor for aspirated air temperature V16 engine (159)
- 15 Sensor for aspirated air temperature V12 engine (203)
- 16 Plug G
- 17 Plug N

The data in brackets refer to the terminal assignment plan

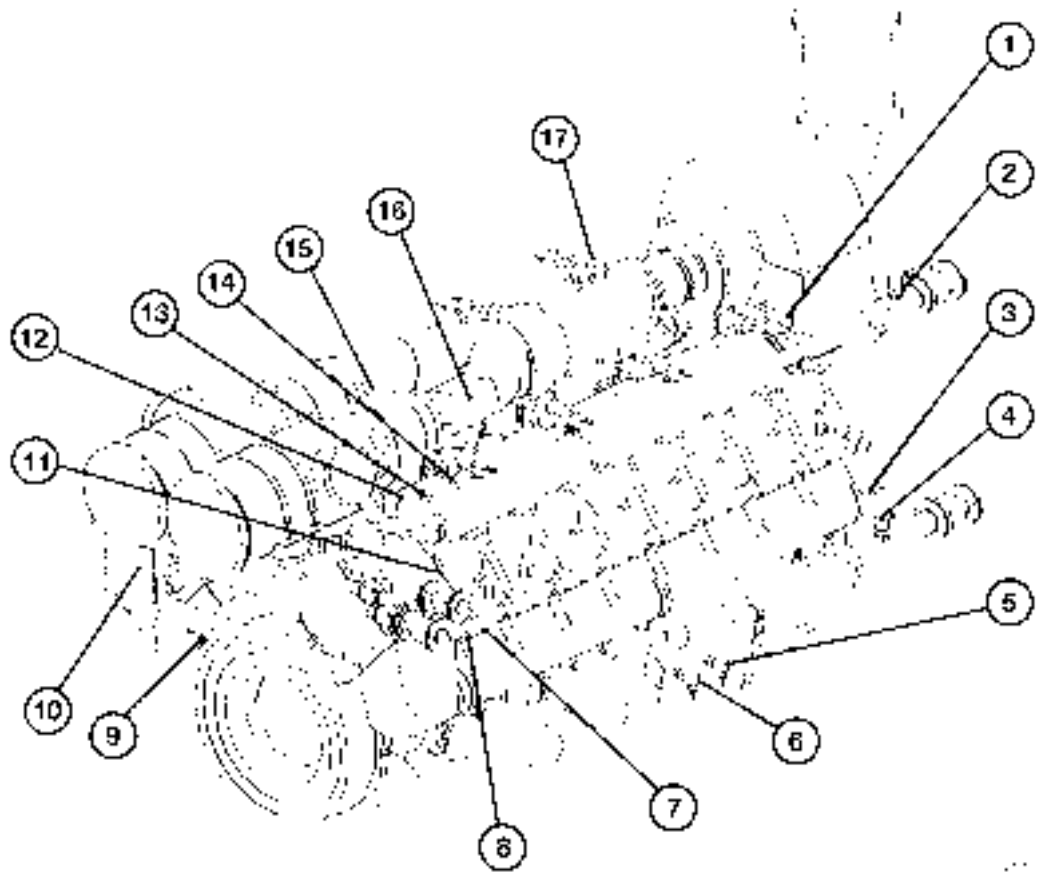

A 2-35 Electrical components (example V16 engine)

- 1 Multi-function rail (cylinder row B)
- 2 Coolant temperature sensor engine outlet (206)
- 3 Temperature sensor (201)
- 4 Coolant temperature sensor engine inlet (207)
- 5 Lube oil temperature sensor (208)
- 6 Lube oil pressure transmitter before filter (196)
- 7 Knocking sensor (251...256)
- 8 Thermocouple (471...476)
- 9 Pickup on the flywheel (200)
- 10 Ignition system TEM-ZS2 / ZS3
- 11 Earthing rail
- 12 Plug F
- 13 Plug E
- 14 Plug H
- 15 Stepper motor (1.5.16)
- 16 Actuator (STG 30)
- 17 Ignition coil

The data in brackets refer to the terminal assignment plan.

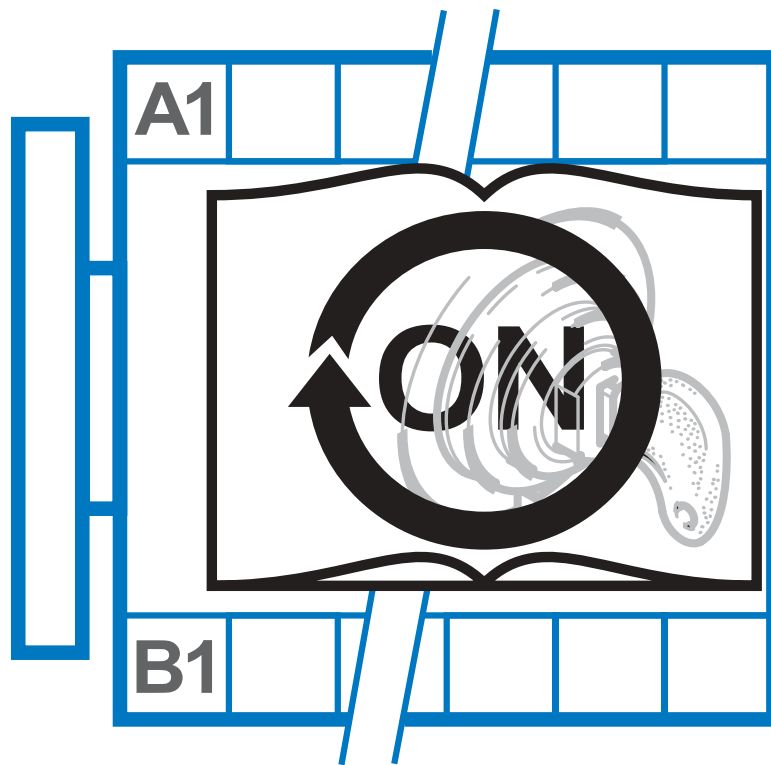



Operation

Work prior to first commissioning and after every inspection

General

The following should be carried out before commissioning, after the engine has been out of operation for a long period and after maintenance and repair work:

- Check all lines and connections for leaks of the following media:
 - Gas
 - Lube oil
 - Coolant
 - Intake air
 - Exhaust gas
- Check linkage of the speed governor for easy action. Check operation of monitoring, shut-off and remote control systems.
- Check the control cable and the sensor with the TEM system self-test.

Filling of coolant

The coolant is filled through the filling nozzle according to operating materials specification with supplements. The coolant chambers are bled by a bleeding line with the coolant pump running. Then check the coolant level again and add coolant if necessary.

Filling of lube oil

The lube oil level is monitored during operation by the TEM system. The approximate lube oil level can be checked with the oil dipstick or is visible in the sight glass. When filling up with lube oil, this should be done in connection with the TEM system.

Too low a level of lube oil leads to non-release or switching off of the engine via monitoring of the lube oil level and the lube oil pressure.

Pre-lubrication

The engine is lubricated by the electric lubrication pump for constant standby at regular intervals. Pre-lubrication must have taken place before the engine has started.

Gas supply



Caution, explosion hazard !

The ventilation system should be switched on before carrying out any work on the gas line.

Smoking and the use of naked flames is prohibited.

Clean the whole line leading to the engine internally (incl. desulphurising system, gas compressor, cooler, gas pressure regulator and shut-off systems). All parts of the line must be dry, clean and free of welding beads, scales and other dirt particles. The joints should be checked for leaks using soapy water, by applying , for example, nitrogen at overpressure.

Note for all heat transformers

Before the insulation is closed, all the screws on pipe and connecting flanges in the exhaust gas system must be tightened. This measure is necessary because of "settling" of the seals.

It is essential to tighten them once more after approx. 100 operating hours or after 14 days.

Failure to do so will result in the manufacturer disclaiming responsibility for leaking seals and escaping exhaust gases.

When filling the water side, bleed constantly (failure to bleed air sufficiently leads to gas accumulations which could damage the boiler).

Particular attention must be paid to contamination of the heating water. Sludge and corrosion products from older heating water circuits and rolling and welding residue can accumulate and cause overheating, voltage peaks and material breakage for example due to local insulation effects.

The heating water side must therefore be checked after the first 10 hours and after a further 100 hours and, if necessary, be cleaned to remove sludge. Sludge drains and filters make this job easier.

Exhaust side

The exhaust gas parts resulting from engine combustion can deposit residue on the smoke pipes.

Although this tendency is only very slight in three-way catalysts, coating on the walls at the transmission surfaces cannot be ruled out over long operating periods. This coating can be removed mechanically or wet chemically.

Note for oxidation catalyst

In systems with an oxidation catalyst the catalyst no longer needs to be removed for commissioning.

Commissioning / Starting

Starting

The values for the suction intake air temperature must be maintained (see chapter 8, Technical data).

The following functions are performed automatically one after the other by the system management TEM system when starting.

- 1 Set the gas cross section at the mixer to start position for the gas type concerned.
- 2 Check that all module components are ready for starting.
- 3 Switch on the starter
- 4 Scavenge air and exhaust gas system
- 5 Switch on the ignition
- 6 Open the gas valve → engine runs up
- 7 Switch off the starter when the speed is high enough and disengage
- 8 Engine accelerates up to rated speed and is ready for synchronisation

Warming up

The engines can be kept constantly at standby temperature by a separate coolant heating (resistance heating or heating by pump operation) even at standstill.

After starting, the engines generally run up quickly to operating temperature, i.e. the set heating lead temperature, by return flow of the heating water. This is independent of the temperature of the heating system. The automatic load connection leads to a reduction in the drop in temperature.

Room ventilation

In the case of engines installed in enclosed spaces, a check must be carried out after start-up as to whether the automatic inlet and outlet air shutters have opened and the fans have started up.

Inadequate engine room ventilation results in excessive room temperatures and a corresponding reduction in output by the engine and generator protection systems in the TEM system.

Lube oil system

The lube oil pressure is monitored and recorded in the TEM system and normally does not need to be checked by the operator again.

Regular checking of the lube oil level and the lube oil supply in the day tank is very important. It should be checked during the inspections with the engine at a standstill. Inspect every 24 h in continuous operation. In case of low lube oil levels the engine is switched off automatically and must be unlocked manually on the switching system after filling with lube oil.

Monitoring operation

System monitoring

All important system parameters of the engine, the generator and the connected heat utilisation system are constantly monitored by the TEM system.

The operating values of the systems must be checked against the recordings made by the TEM system at regular operating intervals (daily in the case of continuous operation). A log is best kept by continuously saving all data to a central PC.

In case of irregularities, defects and faults must be documented by printing out the last 24 h on the system PC printer and by recording them in the operating log. The causes of the fault must then be eliminated.

Engine Peripheral Systems

The temperatures, pressures and other relevant states are monitored automatically, the operating values saved continuously in the module control of the TEM system. If the set maximum values are reached, a warning is issued in the first instance. Then, if exceeded again, the engine is shut off (fault indication).

Coolant circuit



Filling up coolant while the engine is running is prohibited!

Small quantities may be topped up after the engine has been switched off. When filling frequently, make sure that the anti-corrosive content is observed.

Batteries

If the engine has an electric starter, the appropriate batteries and chargers must be checked weekly. The voltage given off by the backup battery of the TEM system is monitored automatically. This serves to back up data in the event of a power failure.



Please note:

The operating manual for the TEM system is available as a separate document and must be ordered separately.

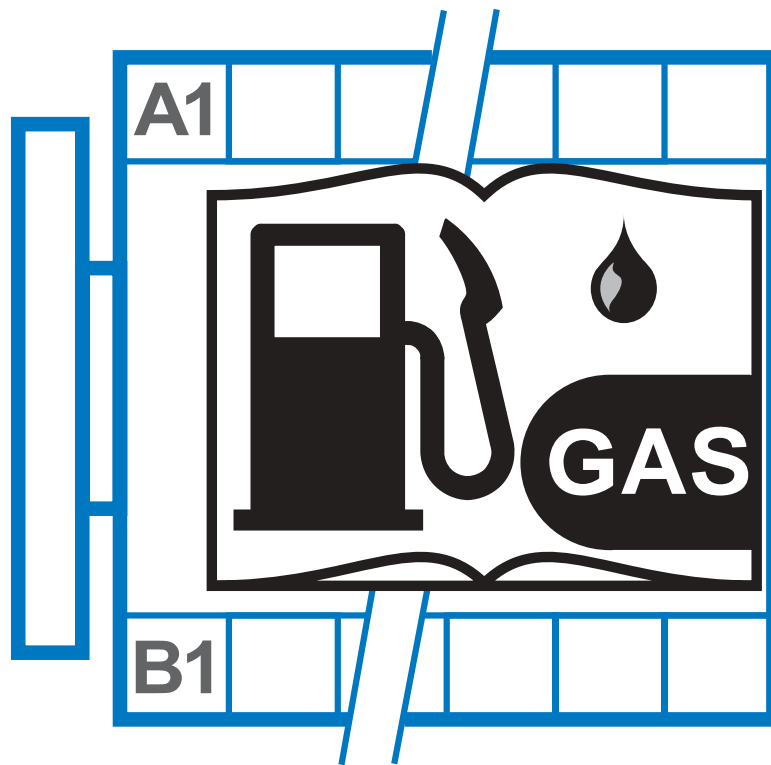



Operating media

General

Guarantee

If unsuitable operating media are used or if no proof can be brought that the used operating media meet the requirements, the engine manufacturer cannot guarantee trouble-free operation. This also applies for defective maintenance of the engines and the operating media.

The most important operating media for gas engine systems are listed in the enclosed operating media specifications. The values specified therein are binding unless specified otherwise in the engine or system-specific contracts.

Product selection

Due to the large number of products in national and international quality and availability and as a result of the constant further development, it is not possible for us to test all suitable products and to name them, we therefore cannot accept any responsibility for these products.

The supplier of the operating materials is solely responsible for the world-wide consistent quality of the products listed here and for products not listed here additionally for meeting the listed requirements for operating media and their operational safety. This also applies for the event that the manufacturer develops the listed products further.

The operating media (reference products) listed here are just a selection of a few manufacturers and their products. Other operating media not listed here can be used if they meet the necessary requirements, i.e. are at least equal in all criteria. The operating media named in this specification are to be used as reference products for comparison. The respective operating media suppliers can provide information about this and should confirm the suitability accordingly.

Mixability

Mixing different expendable types together, e.g. different lube oils with each other, different coolant additives with each other, may lead to malfunctions.

In any case the product supplier's consent must be obtained before mixing and he must take over the responsibility. This also applies for other additives to the operating media.

Fuel gas

see technical circular TR 0199-99-3017.

Lube oil

see technical circular TR 0199-99-2105.

Engine coolant

see technical circular TR 0199-99-2091.

Aids

Sealants and Locking Agents

- Observe storage stability, if any, given on the package!
- Upon transport, storage and disposing of the above-mentioned items, observe chapter 1, Regulations of the operating manual, if no according information is given on the package.

Material designation	Type	Standards and specifications	Characteristics	Application examples
DEUTZ DW 43	Sealant		Solvent-free, rubber base soft elastic hardening, fast skin formation, temperature range 30 °C to 100 °C	Sealing of small joints
DEUTZ DW 47	Sealant	LV 0161 9672 FV 0160 9610	Silicone rubber, tenacious elastic, easily removable, temperature range max. 180 °C, oil max. 150 °C	Sealing of rough and uneven surfaces
DEUTZ DW 48	Sealant	LV 0161 9572 FV 0160 9610	Silicone rubber, tenacious elastic high adhesion strength, temperature range -65 °C to 265 °C	Sealing of rough and uneven surfaces
DEUTZ DW 49	Sealant	LV 0161 9571 FV 0160 9607	Mixed polymerisate of vinyl- und and acryl compounds, high adhesion strength and permanent elasticity, temperature range -40 °C to 130 °C	Sealing of core hole plugs
DEUTZ DW 50	Sealant		Liquid, hardening artificial resin, compatible with flat gaskets temperature range -40 °C to 180 °C	Sealing of housings
DEUTZ DW 51	Sealant	LV 0161 9573	Physically dry artificial resin, permanent elastic and vibration-free temperature range -30 °C to 150 °C	Sealing of surfaces
DEUTZ DW 55	Locking agent	FV 0160 9605	Anaerobic solvent-free single-component substance hardening upon metal contact when excluding oxygen, high strength, fluid, temperature range —55 °C to 150 °C	Securing and sealing of threads up to M12; joints up to max. gap width of 0.15 mm
DEUTZ DW 56	Locking agent	FV 0160 9605	Anaerobic solvent-free single-component substance hardening upon metal contact when excluding oxygen, high strength, viscous, temperature range —55 °C to 150 °C	Securing and sealing of threads up to R2"
DEUTZ DW 57	Locking agent	FV 0160 9605	Anaerobic solvent-free single-component substance hardening upon metal contact when excluding oxygen, low strength, fluid, temperature range —55 °C to 150 °C	Securing and sealing of threads up to M12;
DEUTZ DW 59	Locking agent	FV 0160 9605	Anaerobic solvent-free single-component substance hardening upon metal contact when excluding oxygen, high strength, medium viscous, temperature range —55 °C to 150 °C	Securing and sealing of threads up to M20; joints up to max. gap width of max. 0.15 mm

Material designation	Type	Standards and specifications	Characteristics	Application examples
DEUTZ DW 60	Locking agent	FV 0160 9605	Anaerobic solvent-free single-component substance hardening upon metal contact when excluding oxygen, medium strength, fluid, temperature range —55 °C to 150 °C	Securing and sealing of threads up to M56 or R2"
DEUTZ DW 61	Activator	FV 0160 9605	Accelerates and permits the complete hardening of anaerobic substances with passive materials	Only for passive materials
DEUTZ DW 62	Locking agent	FV 0160 9605	Anaerobic solvent-free single-component substance hardening upon metal contact when excluding oxygen, high strength, medium viscous, thixotropic, temperature range —55 °C to 175 °C	Joints up to a gap width of max. 0.12 mm
DEUTZ DW 63	Sealant	FV 0160 9605	Anaerobic solvent-free single-component substance hardening upon metal contact when excluding oxygen, low strength, viscous, thixotropic, temperature range —55 °C to 150 °C	Sealing of surfaces up to a gap width of max. 0.10 mm
DEUTZ DW 64	Locking agent	FV 0160 9605	Anaerobic solvent-free single-component substance hardening upon metal contact when excluding oxygen, high strength, medium viscous, temperature range —55 °C to 150 °C	Securing and sealing of threads up to M80 or R3"
DEUTZ DW 65	Locking agent	FV 0160 9605	Anaerobic solvent-free single-component substance hardening upon metal contact when excluding oxygen, high strength, viscous, temperature range —55 °C to 150 °C	Joints up to a gap width of max. 0.25 mm
DEUTZ DW 66	Locking agent	FV 0160 9605	Anaerobic solvent-free single-component substance hardening upon metal contact when excluding oxygen, low strength, viscous, temperature range —55 °C to 150 °C	Securing and sealing of threads up to R3"
DEUTZ DW 67	Sealant	FV 0160 0040	Anaerobic solvent-free single-component substance hardening upon metal contact when excluding oxygen, high strength, viscous, temperature range —55 °C to 150 °C	Sealing of surfaces up to a gap width of max. 0.50 mm
DEUTZ DW 68	Sealant	FV 0160 0039	Anaerobic solvent-free single-component substance hardening upon metal contact when excluding oxygen, low strength, viscous, thixotropic, temperature range —55 °C to 150 °C	Sealing of surfaces up to a gap width of max. 0.50 mm, securing and sealing of threads R2"

Material designation	Type	Standards and specifications	Characteristics	Application examples
DEUTZ DW 69	Locking agent	FV 0160 9605	Anaerobic solvent-free single-component substance hardening upon metal contact when excluding oxygen, low strength, fluid, temperature range —55 °C to 150 °C	Securing and sealing of threads up to M36
DEUTZ DW 70	Locking agent	FV 0160 9605	Anaerobic solvent-free single-component substance hardening upon metal contact when excluding oxygen, medium strength, fluid, temperature range —55 °C to 150 °C	Securing and sealing of threads up to M12
DEUTZ DW 71	Locking agent	FV 0160 9605	Anaerobic solvent-free single-component substance hardening upon metal contact when excluding oxygen, high strength, medium viscous, temperature range —55 °C to 175 °C	Securing and sealing of threads up to M20; joints up to a gap width of max. 0.15 mm
DEUTZ DW 72	Locking agent	FV 0160 9605	Anaerobic solvent-free single-component substance hardening upon metal contact when excluding oxygen, medium strength, medium viscous, temperature range —55 °C to 150 °C	Securing and sealing of threads up to M36

T 4-1 Sealants and locking agents

Gluing Agents

Material designation	Type	Standards and specifications	Characteristics	Application examples
DEUTZ KL 1	Gluing agent	LV 0161 9633 FV 0160 9608	Two-component, epoxy-resin based, water-, oil- and diesel fuel resistant, admiss. application temperature max. 150 °C	Combines steel, aluminium, brass and plastic materials such as plexiglass, polyethylene and similar, gluing them together or among them
DEUTZ KL 2	Hardening agent	LV 0161 9633 FV 0160 9608	Mixing ratio 1:1, gluing agent DEUTZ KL 1 and hardener DEUTZ KL 2	

T 4-2 Gluing agents

Lubricants

Material designation	Type	Standards and specifications	Characteristics
DEUTZ S1	FV 0160 9537	-180 °C to 1400 °C	Avoids burning in of screw connections in exhaust gas pipes
DEUTZ S2	LV 0161 9734 FV 0160 9506	-25 °C to 450 °C	Spray, reduces friction and wear on sliding surfaces with difficult access Generates an emergency lubrication and avoids sliding back.
DEUTZ S3	LV 0161 9733 FV 0160 9505	-35 °C to 450 °C	Spray for reducing friction and wear. Generates an emergency lubrication and avoids sliding back.
DEUTZ S4	LV 0161 9735	-40 °C to 450 °C	Preferably used for pre-treating components with a high application temperature. After the evaporation of the carrier oil (at 200 °C), an effectively lubricating solid film remains. Compatible with natural rubber and plastic materials.
DEUTZ S5	LV 0161 9738	-30 °C to 130 °C	For the long-term lubrication of antifriction- and slide bearings with high bearing pressures. Water-resistant, good emergency lubrication
DEUTZ S6	LV 0161 9741	-20 °C to 180 °C	For the long-term lubrication of antifriction- and slide bearings with medium bearing pressures and higher temperatures. Water-resistant, good emergency lubrication
Grease	DIN 51825- KP 2 N-30	-30 °C to 140 °C	Consistent grease for lubricating antifriction bearings, slide bearings and sliding surfaces. For example, for filling the spiral-toothed coupling between the injection pumps.

T 4-3 Lubricants

Other Aids

Please find below a reference list for the auxiliary materials used with which the best results have been achieved. Equivalent products can also be used; in this case, the supplier must guarantee the suitability of the product for the application.

When using the following products it is important to follow the supplier's specifications regarding

- safety instructions,
- personal safety equipment,
- proper use,
- proper disposal

must be observed.

Product group	Application	Product name	Supplier
Cleaning agent for engine components		P3 Cold cleaner (liquid)	Henkel KGAA 40191 Düsseldorf
		Vecom B 24 B (liquid)	Vecom GmbH 21107 Hamburg
		Carbon remover or Ameroid ACC-9 (liquid)	Drew Ameroid Deutschland GmbH 21107 Hamburg
for engine cooling system		P3 T 288 (powder)	Henkel KGAA 40191 Düsseldorf
		P3 Standard (powder)	
		Vecom BA-S (powder)	Vecom GmbH 21107 Hamburg
		Vecom BA-30 (liquid)	
		SAF-Acid (powder)	Drew Ameroid Deutschland GmbH 21107 Hamburg
		HDE-777 (liquid)	
for charge air cooler (water side) and raw water circuit		P3 - T1166	Henkel KGAA 40191 Düsseldorf
		P3 - croni	
		(neutraliser)	
		SAF-Acid (only water softener)	Drew Ameroid Deutschland GmbH 21107 Hamburg
		Concentration: 5 %	
		Temperature: 55 °C - 75 °C	
		Porodox	Collardi GmbH 50825 Köln
for charge air cooler (air side)		ACC 9	Drew Ameroid Deutschland GmbH 21107 Hamburg
		Vecom B 85	Vecom GmbH 21107 Hamburg
		P3T-5308	Henkel KGAA 40191 Düsseldorf
for tank plants		Vecom B 24 B (liquid)	Vecom GmbH 21107 Hamburg
		Vecom B 14 (liquid)	
		Tank cleaner No. 4 (liquid)	Drew Ameroid Deutschland GmbH 21107 Hamburg
to remove preservatives		Eskapon S 255	Haug-Chemie GmbH 74889 Sinsheim
Thinners and removers of wax-like preservatives		Reponal B150	Fuchs Europe GmbH, 68169 Mannheim

Product group	Application	Product name	Supplier
Preservants	Preserving oil for preserving the lube oil system and as a 15% additive for the distillate fuel for fuel systems	Run-in oil SAE30W-30	BP
		BP-MEK 30	Hamburg
	for preserving the coolant system	Puriton 3956	Kuhbier
			Chemie GmbH, 58566 Kierspe
		ODACON Z	Reicon Chemie, 04103 Leipzig
	for preserving bare external surfaces and parts (wax-like)	Gerserol Super	Deutsche Castrol, 76829 Landau
Protective grease for controller linkage and joints	Renolit MP2	Fuchs Europe, 68169 Mannheim	
for rubber parts	fine talcum, white	Silbermann GmbH & Co.KG	
		86456 Gablingen	
Watertreatment agent	Hardness determination for cooling water	Aquamerck Art. No. 11129	E. Merck KGAA 64293 Darmstadt
		DEUTZ ordering no. 1215 8292	
	Cooling water hardening	Vecom CN (powder)	Vecom GmbH 21107 Hamburg
Cooling water softening	Trisodiumphosphate (powder)	Benckiser GmbH, 67001 Ludwigshafen	

T 4-4 Other aids

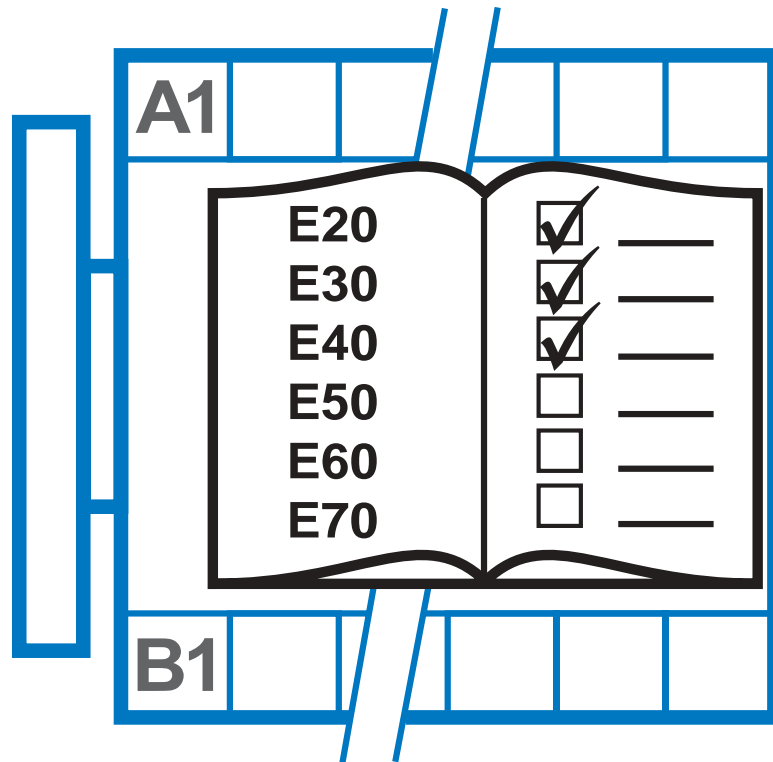



Maintenance



Please bear in mind that the following maintenance schedules are **Scheduled Maintenance Plans**.

It is not possible to make a firm definition of the maintenance intervals for all applications due to the numerous different relationships between ambient conditions, operating mode and quality of fuels.

It may be necessary to shorten the specified maintenance intervals under harsher operating conditions. The scheduled maintenance plan must then be revised completely. Generally the on-site operating conditions are already defined in the planning phase.

Critical operation conditions are for example:

- Contamination of the combustion gases by ingredients which promote wear, e.g. silicon, sulphur, chlorine, ...
- Frequent cold starts
- Increased dust contamination of the suction intake air

Ask your service partner if in doubt.

Continuous supervision

The normal care of your engine comprises a daily visual inspection by technically skilled persons. The appropriate activities are listed in job card B 0-1-5.

Maintenance schedule

General

The maintenance schedule lists the measures for maintaining the nominal condition and thus the operational reliability of the engine and the appropriate maintenance intervals. The maintenance work procedures are described in the specified job cards (AK).

- ‘ The intervals prescribed in the maintenance schedule are maximum values and assume that installation, purpose and operating conditions comply with specifications. It must be ensured that all operating media such as combustion gas, lube oil and coolant are of the prescribed quality. You will find information about this in Chapter 4, Operating Media.



In particular it must be ensured that the gas quality meets the minimum requirements in accordance with TR 0199 - 99 - 3017 to avoid malfunctions and/or premature wear of the engine.

- ‘ This maintenance schedule only applies for the engine itself and the parts attached to the engine. System parts must be serviced at the intervals and according to the instructions specified by the manufacturer. You will find the appropriate information in the enclosed **manufacturer documents** (marked "MD" in the maintenance schedule).
- ‘ The work described must be performed by technically skilled persons or authorised specialists. The competencies are listed in the table of Deutz maintenance and service schedules.

Selection and structure



On reaching the specified intervals of time (months or operating hours), the activities specified in the maintenance schedule must be carried out.

Always use the job card (JC) referred to in the maintenance schedule.

Depending on the speed and gas group, the engine is assigned an appropriate maintenance schedule.

The maintenance schedule consists of several sections which should be used in parallel.

- The maintenance measures independent of operating hours.
The activities to be carried out after reaching the specified time intervals in months are listed here.
- The maintenance measures dependent on operating hours.
The activities to be carried out after reaching the specified time intervals in operating hours (Deutz maintenance and service schedules) are listed here.
- Maintenance measures outside the DEUTZ maintenance and service schedules
The activities for which the time intervals are determined by analysis are listed here.
- The copy forms for proof of maintenance carried out.

Deutz maintenance and service schedules

Maintenance work dependent on operating hours is classified according to Deutz maintenance and service schedules. All the work listed must be performed carefully according to the maintenance schedule determined specifically for the engine.

Deutz maintenance and service schedules		Executed by
E10	each due once after commissioning and after E50, E60 and E70	technically skilled persons
E20	daily check	
E30	periodic maintenance (small scope)	
E40	periodic maintenance (medium scope)	
E50	periodic maintenance (extended scope)	authorised specialists
E60	intermediate overhaul	
E70	complete overhaul	

T 5-1 Deutz maintenance and service schedules



Please note that DEUTZ maintenance and service schedules may be added or omitted depending on the speed and gas group.

- Make sure to observe the due dates for Deutz maintenance and service schedules according to the number of hours your engine has been in operation.
- Arrange the necessary appointment with your responsible service partner in good time. Report any irregularities of your engine when you arrange the appointment.
- Sign a service contract with your service partner if necessary. All the due maintenance work including repairs if agreed is then planned and expertly performed by the service

partner according to the contract. Your service partner will be glad to give you the details.

Definition of activities in the maintenance schedule

Adjust	Adjust torques, dimensions, pressures etc.; extra work may be necessary to renew parts.
Drain water	Drain condensed water for example.
Renew	Renew parts, function groups and liquids.
Recondition	Material removal within the permitted tolerances to reinstate a nominal condition.
Check	Check according to criteria in the job card. If not all criteria are fulfilled, the cause must be found and the nominal condition reinstated.
Clean	Cleaning by hand or machine (automatic), renewal of cleaning parts (e.g. air filters) may be necessary.
Visual inspection	Visual inspection according to criteria in the job card. If not all criteria are fulfilled, the cause must be found and the nominal condition reinstated.
Overhaul	Check function groups, rework or renew parts.
Maintain	Maintain according to job card. Checking of functions; reworking or renewal of parts may be necessary.
Change	Change lube oil for example.

T 5-2 Definition of activities

Gas groups

The maintenance intervals also depend on the quality of the combustion gases.

The combustion gases are divided into two groups according to their wear properties for which different scheduled maintenance plans apply, see also Chapter 4, Technical Circular 0199 - 99 - 3017.



Use the maintenance schedule corresponding to the type of gas used in the system as a basis for the maintenance work.

Gas group 1	Gas group 2 (bio-gases)
Natural gas	Sewage gas
Pit gas	Landfill gas
Liquid gas - propane, butane, LNG (liquid natural gas)	Wood gas
Petroleum gas	Other bio-gases
Gases with a hydrogen content of H ₂ > 30 Vol%, (e.g. coke oven gas)	

T 5-3 Gas groups



The worst determined gas quality is essentially binding for defining the maintenance intervals. Please consult your service partner.

Silicon content



When using combustion gases with a silicon content $> 10 \text{ mg/m}_n^3 \text{ CH}_4$ the TBOs (TBO = Time between overhaul) must be reduced in any case because of the strongly abrasive effect of silicon.

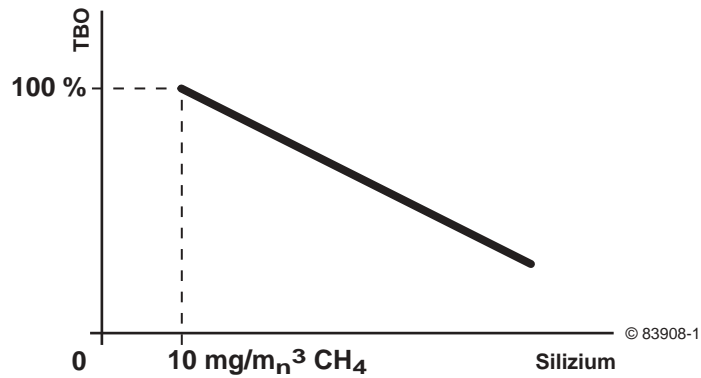

A 5-1 Dependence: Silicon content-TBO

To guarantee the necessary life cycles, the silicon content of critical gases (gas-group 2, bio-gases) must be determined regularly at least 3x a year in the course of extensive gas analyses and the maintenance intervals may have to be shortened accordingly.

Overview of specific maintenance schedules

This engine is built exclusively for the purpose intended according to the scope of delivery as defined by the equipment manufacturer (use for the intended purpose). Depending on its intended purpose the engine is identified by a performance code or an abbreviations for the gas type which is punched into the rating plate. The rating plate is described in detail in chapter 2.

Maintenance schedule 1

Valid for:	Engine type:	V12-, V16- and V20-engine
	Speed:	n = 1,500 rpm (50 Hz applications)
	Fuel gas :	Gas group 1
	Performance code:	ICN
	Type of application:	Current generators

The following activities must be carried out according to the maintenance intervals

Maintenance work independent of operating hours

- as required
- monthly
- after every 4 months
- after every 6 months
- after every 12 months
- after every 24 months

Maintenance work depending on operating hours

E 10	Maintenance	once in special cases
E 20	Inspection	daily
E 30	Maintenance (small scope)	after every 1,500 oh
E 40	Maintenance (medium scope)	after every 3,000 oh
E 50	Maintenance (extended scope)	after every 12,000 oh
E 60	intermediate overhaul	after every 24,000 oh
E 70	complete overhaul	after every 48,000 oh

Maintenance work dependent on operating hours outside the DEUTZ maintenance and service schedule

Lube oil analysis; Initial analysis after 300 op. hrs
according to TR 0199 - 99 - 2105

All other lube oil changes and analyses are to be agreed between the owner and the lab on the basis of the results of the analysis.

Maintenance schedule 2

Valid for:	Engine type:	V12-, V16- and V20-engine
	Speed:	n = 1,500 rpm (50 Hz applications)
	Fuel gas :	Gas group 2
	Performance code:	ICN
	Type of application:	Current generators

The following activities must be carried out according to the maintenance intervals

Maintenance work independent of operating hours

as required
monthly
after every 4 months
after every 6 months
after every 12 months
after every 24 months

Maintenance work depending on operating hours

E 10	Maintenance	once in special cases
E 20	Inspection	daily
E 30	Maintenance (small scope)	after every 1,500 oh
E 40	Maintenance (medium scope)	after every 3,000 oh
E 50	Maintenance (extended scope)	after every 12,000 oh
E 60	intermediate overhaul	after every 24,000 oh
E 70	complete overhaul	after every 48,000 oh

Maintenance work dependent on operating hours outside the DEUTZ maintenance and service schedule

Lube oil analysis; according to TR 0199 - 99 - 2105	Initial analysis after 100 op. hrs
All other lube oil changes and analyses are to be agreed between the owner and the lab on the basis of the results of the analysis.	

Maintenance schedule 3

Valid for:	Engine type :	V12- and V16- engine
	Speed:	n = 1,800 rpm (60 Hz applications)
	Fuel gas :	Gas group 1
	Performance code:	ICN
	Type of application:	Current generators

The following activities must be carried out according to the maintenance intervals

Maintenance work independent of operating hours

as required
monthly
after every 4 months
after every 6 months
after every 12 months
after every 24 months

Maintenance work depending on operating hours

E 10	Maintenance	once in special cases
E 20	Inspection	daily
E 30	Maintenance (small scope)	after every 1,000 oh
E 40	Maintenance (medium scope)	after every 2,000 oh
E 50	Maintenance (extended scope)	after every 10,000 oh
E 60	intermediate overhaul	after every 20,000 oh
E 70	complete overhaul	after every 40,000 oh

Maintenance work dependent on operating hours outside the DEUTZ maintenance and service schedule

Lube oil analysis; according to TR 0199 - 99 - 2105	Initial analysis after 300 op. hrs
All other lube oil changes and analyses are to be agreed between the owner and the lab on the basis of the results of the analysis.	

Maintenance schedule 4

Valid for:	Engine type :	V12- and V16- engine
	Speed:	n = 1,800 rpm (60 Hz applications)
	Fuel gas :	Gas group 2
	Performance code:	ICN
	Type of application:	Current generators

The following activities must be carried out according to the maintenance intervals

Maintenance work independent of operating hours

as required
monthly
after every 4 months
after every 6 months
after every 12 months
after every 24 months

Maintenance work depending on operating hours

E 10	Maintenance	once in special cases
E 20	Inspection	daily
E 30	Maintenance (small scope)	after every 1,000 oh
E 40	Maintenance (medium scope)	after every 2,000 oh
E 50	Maintenance (extended scope)	after every 10,000 oh
E 60	intermediate overhaul	after every 20,000 oh
E 70	complete overhaul	after every 40,000 oh

Maintenance work dependent on operating hours outside the DEUTZ maintenance and service schedule

Lube oil analysis;
according to TR 0199 - 99 - 2105

Initial analysis after 100 op. hrs

All other lube oil changes and analyses are to be agreed between the owner and the lab on the basis of the results of the analysis.

Maintenance schedule 1

Valid for: Engine type: V12-, V16- and V20-engine
 Speed: n = 1,500 rpm (50 Hz applications)
 Fuel gas : Gas group 1

Maintenance work independent of operating hours

as required						Description	Job card 
	monthly	after every 4 months	after every 6 months	after every 12 months	after every 24 months		
x						Check suction air intake filter, renew if necessary; according to E50, but earlier if the maintenance indicator is showing "RED"	B 6-3-6
x						Maintain crankcase vent; according to E40, but earlier if the maintenance indicator is showing "RED"	B 3-1-9
x						Trial run after maintenance work ¹⁾	---
x						Run in engine; after maintenance work such as changing bearings, piston, cylinder liner ²⁾	W 0-1-3
x						Clean the engine	B 0-3-6
	x					Trial run ³⁾	---
	x					Maintaining the battery; according to E30, but monthly if ³⁾ is applicable	B 13-4-1
		x				Gas analysis	---
			x			Check percentage of corrosion protection agent or antifreeze in the coolant	B 9-1-1
			x	x		Inspect pressure drop in gas filter	MD
				x		Renew gas filter insert	B 7-21-1
				x		Gas pressure sensor, check set gas pressure	MD
				x		Check gas pressure regulator	MD
				x		Check shutoff valves of the gas control system	MD
				x		Check the entire gas control system for leaks	MD
				x		Lube oil change ⁴⁾	B 8-1-2
				x		Renew lube oil filter cartridge ⁴⁾	B 8-10-4
					x	Renew the coolant	B 9-0-4

1) To be performed by maintenance officers

2) To be performed by authorised experts

3) This activity must be performed when the engine on standby has not been operated for longer than one month. The engine must be preserved during long periods out of action, e.g. over the winter - see chapter 7.

4) The lube oil must be changed if the maintenance intervals determined in the lube oil analysis are not reached within 12 months. The lube oil filter cartridge must be used.

Maintenance work depending on operating hours

E10	E20	E30	E40	E50	E60	E70	Description	Job card
1x after 50 oh	after every 24 hrs (daily)	after every 1,500 oh	after every 3,000 oh	after every 12,000 oh	after every 24,000 oh	after every 48,000 oh		
x	x	x	x	x	x	x	Visual inspection of the system	B 0-1-5
x		x	x	x	x	x	Test and function run	TEM
x		x	x				Checking valve clearance	B 1-1-1
		x	x	x	x	x	Maintaining battery ¹⁾	B 13-4-1
		x	x	x	x	x	Checking speed governor linkage	B 5-4-2
		x	x	x	x	x	Maintaining crankcase bleed valve (Racor model) ¹⁾	B 3-1-9
				x	x	x	Renewing crankcase bleed valve (Mann model) ¹⁾	B 3-1-6
		x					Checking spark plugs, renewing if necessary	B 13-5-4
			x	x	x	x	Renewing spark plugs	B 13-5-4
x ²⁾			x	x	x	x	Renewing lube oil filter cartridge ³⁾	B 8-10-4
			x	x	x	x	Checking ignition time	B 13-5-3
			x	x	x	x	Auxiliary unit test using the TEM System	B 0-1-6
				x	x	x	Renewing suction air intake filter, cleaning suction air filter housing	B 6-3-6
				x	x	x	Checking engine fastening	W 3-7-1
				x	x	x	Checking starter pinion and ring gear	W 12-6-4
				x	x	x	Renewing or overhauling cylinder heads	W 1-4-4
				x			Cleaning combustion chambers	---
				x			Checking cylinder liners	W 3-3-1
					x	x	Renewing cylinder liners	W 3-3-2
				x			Checking and endoscoping intercooler	W 6-4-11
					x	x	Cleaning intercooler	W 6-4-4
				x			Checking and cleaning turbocharger ⁴⁾	MD
					x	x	Renewing or overhauling turbocharger ⁴⁾	MD
				x	x		Cleaning gas mixer	W 7-22-2
						x	Renewing gas mixer	W 7-22-1
					x		Checking rubber compensators	W 12-3-1
						x	Renewing rubber compensators	W 12-3-1

1) For engines with this equipment

2) Only 50 oh as per E50 to E70

3) For other lube oil filter changes, see TC 0199 - 99 - 2105

4) Maintenance intervals, see manufacturer documentation (MD)

E10	E20	E30	E40	E50	E60	E70	Description	Job card
1x after 50 oh	after every 24 hrs (daily)	after every 1,500 oh	after every 3,000 oh	after every 12,000 oh	after every 24,000 oh	after every 48,000 oh		
					x	x	Checking hose pipes, vibration dampers and flexible lines	---
					x	x	Checking engine side fittings and control instruments	---
					x	x	Renew viscosity torsional vibration dampers ¹⁾	---
					x		Checking crankshaft axial clearance	W 2-1-4
					x		Checking camshaft axial clearance	W 4-1-4
					x		Checking valve tappet	W 4-2-1
						x	Renewing valve tappet	W 4-2-1
					x		Checking con rod liners	W 2-3-3
					x	x	Renewing con rod bearings	W 2-5-1
					x		Checking piston	W 2-9-7
						x	Renewing piston	W 2-9-3
					x		Checking piston pin	W 2-12-4
					x		Renewing piston rings	W 2-10-1
					x	x	Checking camshaft	W 4-5-1
						x	Renewing camshaft bearing	W 4-1-1
						x	Renewing con rods	W 2-3-6
						x	Renewing drive side crankshaft sealing ring	W 2-2-2
						x	Renewing free side crankshaft sealing ring ¹⁾	W 2-2-4
						x	Measuring crankshaft, checking for tears, polishing	W 2-1-7
						x	Checking and cleaning wheel drive and control	W 4-4-1
						x	Renewing main bearing and axial bearing	W 2-7-3
						x	Renewing or overhauling lube oil pump	W 8-4-5
						x	Renewing or overhauling pressure limiting valve	---
						x	Renewing exhaust gas compensators	---

1) For engines with this equipment

2) Only 50 oh as per E50 to E70

3) For other lube oil filter changes, see TC 0199 - 99 - 2105

4) Maintenance intervals, see manufacturer documentation (MD)

T 5-1 Maintenance work depending on operating hours

Maintenance work dependent on operating hours outside the DEUTZ maintenance and service schedules

Description	Job card 
Lube oil analysis (according to TR 0199 - 99 - 2105) Initial analysis after 300 op. hrs All other lube oil changes and analyses are to be agreed between the owner and the lab on the basis of the results of the analysis.	---

T 5-2 Maintenance work outside the DEUTZ maintenance and service schedules



We recommend you to record the proper execution of the work in the enclosed maintenance tables.

Proof of maintenance performed

Copy form for maintenance work independent of operating hours

Date	Activity	Signature

Table for maintenance work dependent on operating hours

Hours	Deutz maintenance and service schedule						Date	Signature
	E10	E30	E40	E50	E60	E70		
50	1							
1.500		1						
3.000			1					
4.500		2						
6.000			2					
7.500		3						
9.000			3					
10.500		4						
12.000				1				
12.050	2							
13.500		5						
15.000			4					
16.500		6						
18.000			5					
19.500		7						
21.000			6					
22.500		8						
24.000					1			
24.050	3							
25.500		9						
27.000			7					
28.500		10						
30.000			8					
31.500		11						
33.000			9					
34.500		12						
36.000				2				
36.050	4							
37.500		13						
39.000			10					
40.500		14						
42.000			11					
43.500		15						
45.000			12					
46.500		16						

Hours	Deutz maintenance and service schedule						Date	Signature
	E10	E30	E40	E50	E60	E70		
48.000						1		

Number of Deutz maintenance and service schedules up to and including complete overhaul

Total	4	16	12	2	1	1
-------	---	----	----	---	---	---

Maintenance schedule 2

Valid for: Engine type: V12-, V16- and V20-engine
 Speed: n = 1,500 rpm (50 Hz applications)
 Fuel gas : Gas group 2

Maintenance work independent of operating hours

as required						Description	Job card 
	monthly	after every 4 months	after every 6 months	after every 12 months	after every 24 months		
x						Check suction air intake filter, renew if necessary; according to E50, but earlier if the maintenance indicator is showing "RED"	B 6-3-6
x						Maintain crankcase vent; according to E40, but earlier if the maintenance indicator is showing "RED"	B 3-1-9
x						Trial run after maintenance work ¹⁾	---
x						Run in engine; after maintenance work such as changing bearings, piston, cylinder liner ²⁾	W 0-1-3
x						Clean the engine	B 0-3-6
	x					Trial run ³⁾	---
	x					Maintaining the battery; according to E30, but monthly if ³⁾ is applicable	B 13-4-1
		x				Gas analysis	---
			x			Check percentage of corrosion protection agent or antifreeze in the coolant	B 9-1-1
			x	x		Inspect pressure drop in gas filter	MD
				x		Renew gas filter insert	B 7-21-1
				x		Gas pressure sensor, check set gas pressure	MD
				x		Check gas pressure regulator	MD
				x		Check shutoff valves of the gas control system	MD
				x		Check the entire gas control system for leaks	MD
				x		Lube oil change ⁴⁾	B 8-1-2
				x		Renew lube oil filter cartridge ⁴⁾	B 8-10-4
					x	Renew the coolant	B 9-0-4

1) To be performed by maintenance officers

2) To be performed by authorised experts

3) This activity must be performed when the engine on standby has not been operated for longer than one month. The engine must be preserved during long periods out of action, e.g. over the winter - see chapter 7.

4) The lube oil must be changed if the maintenance intervals determined in the lube oil analysis are not reached within 12 months. The lube oil filter cartridge must be used.

Maintenance work depending on operating hours

E10	E20	E30	E40	E50	E60	E70	Description	Job card
1x after 50 oh	after every 24 hrs (daily)	after every 1,500 oh	after every 3,000 oh	after every 12,000 oh	after every 24,000 oh	after every 48,000 oh		
x	x	x	x	x	x	x	Visual inspection of the system	B 0-1-5
x		x	x	x	x	x	Test and function run	TEM
x		x	x				Checking valve clearance	B 1-1-1
		x	x	x	x	x	Maintaining battery ¹⁾	B 13-4-1
		x	x	x	x	x	Checking speed governor linkage	B 5-4-2
		x	x	x	x	x	Maintaining crankcase bleed valve (Racor model) ¹⁾	B 3-1-9
				x	x	x	Renewing crankcase bleed valve (Mann model) ¹⁾	B 3-1-6
		x					Checking spark plugs, renewing if necessary	B 13-5-4
			x	x	x	x	Renewing spark plugs	B 13-5-4
x ²⁾			x	x	x	x	Renewing lube oil filter cartridge ³⁾	B 8-10-4
			x	x	x	x	Checking ignition time	B 13-5-3
			x	x	x	x	Auxiliary unit test using the TEM System	B 0-1-6
				x	x	x	Renewing suction air intake filter, cleaning suction air filter housing	B 6-3-6
				x	x	x	Checking engine fastening	W 3-7-1
				x	x	x	Checking starter pinion and ring gear	W 12-6-4
				x	x	x	Renewing or overhauling cylinder heads	W 1-4-4
				x			Cleaning combustion chambers	---
				x			Checking cylinder liners	W 3-3-1
					x	x	Renewing cylinder liners	W 3-3-2
				x			Checking and endoscoping intercooler	W 6-4-11
					x	x	Cleaning intercooler	W 6-4-4
				x			Checking and cleaning turbocharger ⁴⁾	MD
					x	x	Renewing or overhauling turbocharger ⁴⁾	MD
				x	x		Cleaning gas mixer	W 7-22-2
						x	Renewing gas mixer	W 7-22-1
					x		Checking rubber compensators	W 12-3-1
						x	Renewing rubber compensators	W 12-3-1

1) For engines with this equipment

2) Only 50 oh as per E50 to E70

3) For other lube oil filter changes, see TC 0199 - 99 - 2105

4) Maintenance intervals, see manufacturer documentation (MD)

E10	E20	E30	E40	E50	E60	E70	Description	Job card
1x after 50 oh	after every 24 hrs (daily)	after every 1,500 oh	after every 3,000 oh	after every 12,000 oh	after every 24,000 oh	after every 48,000 oh		
					x	x	Checking hose pipes, vibration dampers and flexible lines	---
					x	x	Checking engine side fittings and control instruments	---
					x	x	Renew viscosity torsional vibration dampers ¹⁾	---
					x		Checking crankshaft axial clearance	W 2-1-4
					x		Checking camshaft axial clearance	W 4-1-4
					x		Checking valve tappet	W 4-2-1
						x	Renewing valve tappet	W 4-2-1
					x		Checking con rod liners	W 2-3-3
					x	x	Renewing con rod bearings	W 2-5-1
					x		Checking piston	W 2-9-7
						x	Renewing piston	W 2-9-3
					x		Checking piston pin	W 2-12-4
					x		Renewing piston rings	W 2-10-1
					x	x	Checking camshaft	W 4-5-1
						x	Renewing camshaft bearing	W 4-1-1
						x	Renewing con rods	W 2-3-6
						x	Renewing drive side crankshaft sealing ring	W 2-2-2
						x	Renewing free side crankshaft sealing ring ¹⁾	W 2-2-4
						x	Measuring crankshaft, checking for tears, polishing	W 2-1-7
						x	Checking and cleaning wheel drive and control	W 4-4-1
						x	Renewing main bearing and axial bearing	W 2-7-3
						x	Renewing or overhauling lube oil pump	W 8-4-5
						x	Renewing or overhauling pressure limiting valve	---
						x	Renewing exhaust gas compensators	---

- 1) For engines with this equipment
- 2) Only 50 oh as per E50 to E70
- 3) For other lube oil filter changes, see TC 0199 - 99 - 2105
- 4) Maintenance intervals, see manufacturer documentation (MD)

T 5-1 Maintenance work depending on operating hours

Maintenance work dependent on operating hours outside the DEUTZ maintenance and service schedules

Description	Job card 
Lube oil analysis (according to TR 0199 - 99 - 2105) Initial analysis after 100 op. hrs All other lube oil changes and analyses are to be agreed between the owner and the lab on the basis of the results of the analysis.	---

T 5-2 Maintenance work outside the DEUTZ maintenance and service schedules



We recommend you to record the proper execution of the work in the enclosed maintenance tables.

Table for maintenance work dependent on operating hours

Hours	Deutz maintenance and service schedule						Date	Signature
	E10	E30	E40	E50	E60	E70		
50	1							
1.500		1						
3.000			1					
4.500		2						
6.000			2					
7.500		3						
9.000			3					
10.500		4						
12.000				1				
12.050	2							
13.500		5						
15.000			4					
16.500		6						
18.000			5					
19.500		7						
21.000			6					
22.500		8						
24.000					1			
24.050	3							
25.500		9						
27.000			7					
28.500		10						
30.000			8					
31.500		11						
33.000			9					
34.500		12						
36.000				2				
36.050	4							
37.500		13						
39.000			10					
40.500		14						
42.000			11					
43.500		15						
45.000			12					
46.500		16						

Hours	Deutz maintenance and service schedule						Date	Signature
	E10	E30	E40	E50	E60	E70		
48.000						1		

Number of Deutz maintenance and service schedules up to and including complete overhaul

Total	4	16	12	2	1	1
-------	---	----	----	---	---	---

Maintenance schedule 3

Valid for: Engine type : V12- and V16- engine
 Speed: n = 1,800 rpm (60 Hz applications)
 Fuel gas : Gas group 1

Maintenance work independent of operating hours

as required						Description	Job card 
	monthly	after every 4 months	after every 6 months	after every 12 months	after every 24 months		
x						Check suction air intake filter, renew if necessary; according to E50, but earlier if the maintenance indicator is showing "RED"	B 6-3-6
x						Maintain crankcase vent; according to E40, but earlier if the maintenance indicator is showing "RED"	B 3-1-9
x						Trial run after maintenance work ¹⁾	---
x						Run in engine; after maintenance work such as changing bearings, piston, cylinder liner ²⁾	W 0-1-3
x						Clean the engine	B 0-3-6
	x					Trial run ³⁾	---
	x					Maintaining the battery; according to E30, but monthly if ³⁾ is applicable	B 13-4-1
		x				Gas analysis	---
			x			Check percentage of corrosion protection agent or antifreeze in the coolant	B 9-1-1
			x	x		Inspect pressure drop in gas filter	MD
				x		Renew gas filter insert	B 7-21-1
				x		Gas pressure sensor, check set gas pressure	MD
				x		Check gas pressure regulator	MD
				x		Check shutoff valves of the gas control system	MD
				x		Check the entire gas control system for leaks	MD
				x		Lube oil change ⁴⁾	B 8-1-2
				x		Renew lube oil filter cartridge ⁴⁾	B 8-10-4
					x	Renew the coolant	B 9-0-4

1) To be performed by maintenance officers

2) To be performed by authorised experts

3) This activity must be performed when the engine on standby has not been operated for longer than one month. The engine must be preserved during long periods out of action, e.g. over the winter - see chapter 7.

4) The lube oil must be changed if the maintenance intervals determined in the lube oil analysis are not reached within 12 months. The lube oil filter cartridge must be used.

Maintenance work depending on operating hours

E10	E20	E30	E40	E50	E60	E70	Description	Job card
1x after 50 oh	after every 24 hrs (daily)	after every 1,000 oh	after every 2,000 oh	after every 10,000 oh	after every 20,000 oh	after every 40,000 oh		
x	x	x	x	x	x	x	Visual inspection of the system	B 0-1-5
x		x	x	x	x	x	Test and function run	TEM
x		x	x				Checking valve clearance	B 1-1-1
		x	x	x	x	x	Maintaining battery ¹⁾	B 13-4-1
		x	x	x	x	x	Checking speed governor linkage	B 5-4-2
		x	x	x	x	x	Maintaining crankcase bleed valve (Racor model) ¹⁾	B 3-1-9
				x	x	x	Renewing crankcase bleed valve (Mann model) ¹⁾	B 3-1-6
		x					Checking spark plugs, renewing if necessary	B 13-5-4
			x	x	x	x	Renewing spark plugs	B 13-5-4
x ²⁾			x	x	x	x	Renewing lube oil filter cartridge ³⁾	B 8-10-4
			x	x	x	x	Checking ignition time	B 13-5-3
			x	x	x	x	Auxiliary unit test using the TEM System	B 0-1-6
				x	x	x	Renewing suction air intake filter, cleaning suction air intake filter housing	B 6-3-6
				x	x	x	Checking engine fastening	W 3-7-1
				x	x	x	Checking starter pinion and ring gear	W 12-6-4
				x	x	x	Renewing or overhauling cylinder heads	W 1-4-4
				x			Cleaning combustion chambers	---
				x			Checking cylinder liners	W 3-3-1
					x	x	Renewing cylinder liners	W 3-3-2
				x			Checking and endoscoping intercooler	W 6-4-11
					x	x	Cleaning intercooler	W 6-4-4
				x			Checking and cleaning turbocharger ⁴⁾	MD
					x	x	Renewing or overhauling turbocharger ⁴⁾	MD
				x	x		Cleaning gas mixer	W 7-22-2
						x	Renewing gas mixer	W 7-22-1
					x		Checking rubber compensators	W 12-3-1
						x	Renewing rubber compensators	W 12-3-1

1) For engines with this equipment

2) Only 50 oh as per E50 to E70

3) For other lube oil filter changes, see TC 0199 - 99 - 2105

4) Maintenance intervals, see manufacturer documentation (MD)

E10	E20	E30	E40	E50	E60	E70	Description	Job card
1x after 50 oh	after every 24 hrs (daily)	after every 1,000 oh	after every 2,000 oh	after every 10,000 oh	after every 20,000 oh	after every 40,000 oh		
					x	x	Checking hose pipes, vibration dampers and flexible lines	---
					x	x	Checking engine side fittings and control instruments	---
					x	x	Renewing viscosity torsional vibration dampers ¹⁾	---
					x		Checking crankshaft axial clearance	W 2-1-4
					x		Checking camshaft axial clearance	W 4-1-4
					x		Checking valve tappet	W 4-2-1
						x	Renewing valve tappet	W 4-2-1
					x		Checking con rod liners	W 2-3-3
					x	x	Renewing con rod bearings	W 2-5-1
					x		Checking piston	W 2-9-7
						x	Renewing piston	W 2-9-3
					x		Checking piston pin	W 2-12-4
					x		Renewing piston rings	W 2-10-1
					x	x	Checking camshaft	W 4-5-1
						x	Renewing camshaft bearing	W 4-1-1
						x	Renewing con rods	W 2-3-6
						x	Renewing drive side crankshaft sealing ring	W 2-2-2
						x	Renewing free side crankshaft sealing ring ¹⁾	W 2-2-4
						x	Measuring crankshaft, checking for tears, polishing	W 2-1-7
						x	Checking and cleaning wheel drive and control	W 4-4-1
						x	Renewing main bearing and axial bearing	W 2-7-3
						x	Renewing or overhauling lube oil pump	W 8-4-5
						x	Renewing or overhauling pressure limiting valve	---
						x	Renewing exhaust gas compensators	---

1) For engines with this equipment

2) Only 50 oh as per E50 to E70

3) For other lube oil filter changes, see TC 0199 - 99 - 2105

4) Maintenance intervals, see manufacturer documentation (MD)

T 5-1 Maintenance work depending on operating hours

Maintenance work dependent on operating hours outside the DEUTZ maintenance and service schedules

Description	Job card 
Lube oil analysis (according to TR 0199 - 99 - 2105) Initial analysis after 300 op. hrs All other lube oil changes and analyses are to be agreed between the owner and the lab on the basis of the results of the analysis.	---

T 5-2 Maintenance work outside the DEUTZ maintenance and service schedules



We recommend you to record the proper execution of the work in the enclosed maintenance tables.

Table for maintenance work dependent on operating hours

Hours	Deutz maintenance and service schedule						Date	Signature
	E10	E30	E40	E50	E60	E70		
50	1							
1.000		1						
2.000			1					
3.000		2						
4.000			2					
5.000		3						
6.000			3					
7.000		4						
8.000			4					
9.000		5						
10.000				1				
10.050	2							
11.000		6						
12.000			5					
13.000		7						
14.000			6					
15.000		8						
16.000			7					
17.000		9						
18.000			8					
19.000		10						
20.000					1			
20.050	3							
21.000		11						
22.000			9					
23.000		12						
24.000			10					
25.000		13						
26.000			11					
27.000		14						
28.000			12					
29.000		15						
30.000				2				
30.050	4							
31.000		16						

Hours	Deutz maintenance and service schedule						Date	Signature
	E10	E30	E40	E50	E60	E70		
32.000			13					
33.000		17						
34.000			14					
35.000		18						
36.000			15					
37.000		19						
38.000			16					
39.000		20						
40.000						1		

Number of Deutz maintenance and service schedules up to and including complete overhaul

Total 4 20 16 2 1 1

Maintenance schedule 4

Valid for: Engine type : V12- and V16- engine
 Speed: n = 1,800 rpm (60 Hz applications)
 Fuel gas : Gas group 2

Maintenance work independent of operating hours

as required						Description	Job card 
	monthly	after every 4 months	after every 6 months	after every 12 months	after every 24 months		
x						Check suction air intake filter, renew if necessary; according to E50, but earlier if the maintenance indicator is showing "RED"	B 6-3-6
x						Maintain crankcase vent; according to E40, but earlier if the maintenance indicator is showing "RED"	B 3-1-9
x						Trial run after maintenance work ¹⁾	---
x						Run in engine; after maintenance work such as changing bearings, piston, cylinder liner ²⁾	W 0-1-3
x						Clean the engine	B 0-3-6
	x					Trial run ³⁾	---
	x					Maintaining the battery; according to E30, but monthly if ³⁾ is applicable	B 13-4-1
		x				Gas analysis	---
			x			Check percentage of corrosion protection agent or antifreeze in the coolant	B 9-1-1
			x	x		Inspect pressure drop in gas filter	MD
				x		Renew gas filter insert	B 7-21-1
				x		Gas pressure sensor, check set gas pressure	MD
				x		Check gas pressure regulator	MD
				x		Check shutoff valves of the gas control system	MD
				x		Check the entire gas control system for leaks	MD
				x		Lube oil change ⁴⁾	B 8-1-2
				x		Renew lube oil filter cartridge ⁴⁾	B 8-10-4
					x	Renew the coolant	B 9-0-4

1) To be performed by maintenance officers

2) To be performed by authorised experts

3) This activity must be performed when the engine on standby has not been operated for longer than one month. The engine must be preserved during long periods out of action, e.g. over the winter - see chapter 7.

4) The lube oil must be changed if the maintenance intervals determined in the lube oil analysis are not reached within 12 months. The lube oil filter cartridge must be used.

Maintenance work depending on operating hours

E10	E20	E30	E40	E50	E60	E70	Description	Job card
1x after 50 oh	after every 24 hrs (daily)	after every 1,000 oh	after every 2,000 oh	after every 10,000 oh	after every 20,000 oh	after every 40,000 oh		
x	x	x	x	x	x	x	Visual inspection of the system	B 0-1-5
x		x	x	x	x	x	Test and function run	TEM
x		x	x				Checking valve clearance	B 1-1-1
		x	x	x	x	x	Maintaining battery ¹⁾	B 13-4-1
		x	x	x	x	x	Checking speed governor linkage	B 5-4-2
		x	x	x	x	x	Maintaining crankcase bleed valve (Racor model) ¹⁾	B 3-1-9
				x	x	x	Renewing crankcase bleed valve (Mann model) ¹⁾	B 3-1-6
		x					Checking spark plugs, renewing if necessary	B 13-5-4
			x	x	x	x	Renewing spark plugs	B 13-5-4
x ²⁾			x	x	x	x	Renewing lube oil filter cartridge ³⁾	B 8-10-4
			x	x	x	x	Checking ignition time	B 13-5-3
			x	x	x	x	Auxiliary unit test using the TEM System	B 0-1-6
				x	x	x	Renewing suction air intake filter, cleaning suction air intake filter housing	B 6-3-6
				x	x	x	Checking engine fastening	W 3-7-1
				x	x	x	Checking starter pinion and ring gear	W 12-6-4
				x	x	x	Renewing or overhauling cylinder heads	W 1-4-4
				x			Cleaning combustion chambers	---
				x			Checking cylinder liners	W 3-3-1
					x	x	Renewing cylinder liners	W 3-3-2
				x			Checking and endoscoping intercooler	W 6-4-11
					x	x	Cleaning intercooler	W 6-4-4
				x			Checking and cleaning turbocharger ⁴⁾	MD
					x	x	Renewing or overhauling turbocharger ⁴⁾	MD
				x	x		Cleaning gas mixer	W 7-22-2
						x	Renewing gas mixer	W 7-22-1
					x		Checking rubber compensators	W 12-3-1
						x	Renewing rubber compensators	W 12-3-1

1) For engines with this equipment

2) Only 50 oh as per E50 to E70

3) For other lube oil filter changes, see TC 0199 - 99 - 2105

4) Maintenance intervals, see manufacturer documentation (MD)

E10	E20	E30	E40	E50	E60	E70	Description	Job card
1x after 50 oh	after every 24 hrs (daily)	after every 1,000 oh	after every 2,000 oh	after every 10,000 oh	after every 20,000 oh	after every 40,000 oh		
					x	x	Checking hose pipes, vibration dampers and flexible lines	---
					x	x	Checking engine side fittings and control instruments	---
					x	x	Renewing viscosity torsional vibration dampers ¹⁾	---
					x		Checking crankshaft axial clearance	W 2-1-4
					x		Checking camshaft axial clearance	W 4-1-4
					x		Checking valve tappet	W 4-2-1
						x	Renewing valve tappet	W 4-2-1
					x		Checking con rod liners	W 2-3-3
					x	x	Renewing con rod bearings	W 2-5-1
					x		Checking piston	W 2-9-7
						x	Renewing piston	W 2-9-3
					x		Checking piston pin	W 2-12-4
					x		Renewing piston rings	W 2-10-1
					x	x	Checking camshaft	W 4-5-1
						x	Renewing camshaft bearing	W 4-1-1
						x	Renewing con rods	W 2-3-6
						x	Renewing drive side crankshaft sealing ring	W 2-2-2
						x	Renewing free side crankshaft sealing ring ¹⁾	W 2-2-4
						x	Measuring crankshaft, checking for tears, polishing	W 2-1-7
						x	Checking and cleaning wheel drive and control	W 4-4-1
						x	Renewing main bearing and axial bearing	W 2-7-3
						x	Renewing or overhauling lube oil pump	W 8-4-5
						x	Renewing or overhauling pressure limiting valve	---
						x	Renewing exhaust gas compensators	---

1) For engines with this equipment

2) Only 50 oh as per E50 to E70

3) For other lube oil filter changes, see TC 0199 - 99 - 2105

4) Maintenance intervals, see manufacturer documentation (MD)

T 5-1 Maintenance work depending on operating hours

Maintenance work dependent on operating hours outside the DEUTZ maintenance and service schedules

Description	Job card 
Lube oil analysis (according to TR 0199 - 99 - 2105) Initial analysis after 100 op. hrs All other lube oil changes and analyses are to be agreed between the owner and the lab on the basis of the results of the analysis.	---

T 5-2 Maintenance work outside the DEUTZ maintenance and service schedules



We recommend you to record the proper execution of the work in the enclosed maintenance tables.

Table for maintenance work dependent on operating hours

Hours	Deutz maintenance and service schedule						Date	Signature
	E10	E30	E40	E50	E60	E70		
50	1							
1.000		1						
2.000			1					
3.000		2						
4.000			2					
5.000		3						
6.000			3					
7.000		4						
8.000			4					
9.000		5						
10.000				1				
10.050	2							
11.000		6						
12.000			5					
13.000		7						
14.000			6					
15.000		8						
16.000			7					
17.000		9						
18.000			8					
19.000		10						
20.000					1			
20.050	3							
21.000		11						
22.000			9					
23.000		12						
24.000			10					
25.000		13						
26.000			11					
27.000		14						
28.000			12					
29.000		15						
30.000				2				
30.050	4							
31.000		16						

Hours	Deutz maintenance and service schedule						Date	Signature
	E10	E30	E40	E50	E60	E70		
32.000			13					
33.000		17						
34.000			14					
35.000		18						
36.000			15					
37.000		19						
38.000			16					
39.000		20						
40.000						1		

Number of Deutz maintenance and service schedules up to and including complete overhaul

Total 4 20 16 2 1 1

Operating check log

Keep an operating check log! A copy form is provided on the next page. Please not down all irregularities (warnings, faults) and maintenance work in this log. This means you always have a good idea when maintenance work is due, and you can document all irregularities for our service personnel. If you have connected a printer to your TEM system, print out a copy of the measured values in the event of warnings or faults.



Danger of destruction !

Further operation of the engine in the case of a warning or restarting after a fault without eliminating the cause can lead to total engine failure.

Operating check log (form for copying)



**Do not reset any warning/fault messages before you have ascertained the cause.
Please see the notes in the operating manual.**

Enclosures:		Engine type:	Page:
Date Time	Module Operating hours	Event Measure	Signature / Printer doc. no.

T 5-1 Operating check log (form for copying)

Tools for competence class 1

Order address

The tools can be ordered from your DEUTZ Power Systems Service.

Tools sorted according to order numbers

Name	Figure
1 Description / Use	(The illustrations are examples)
2 Module	
3 Competence class	
4 Order number / Order from ...	

Torque wrench

- 1 Measuring range 0-21 Nm (0-2.1 kpm)
- 2 00 General
- 3 (1)
- 4 1203 0350 / Service Partner



Name	Figure
1 Description / Use	(The illustrations are examples)
2 Module	
3 Competence class	
4 Order number / Order from ...	

Tool kit

- 1 Standard set
- 2 00 General
- 3 (1)
- 4 1212 8419 / Service Partner



comprising:

- Tool case
- Open-end spanner 46
- Open-end spanner 36 x 41 DIN 3110
- Socket 22 x 12.5 DIN 3124
- Socket 24 x 20 DIN 3124
- Socket 27 x 20 DIN 3124
- Socket 30 x 20 DIN 3124
- Socket 32 x 20 DIN 3124
- Socket key size 36, extra deep
- Socket key, inside size 17
- Slider CH 1772/39
- Extension CH 1772/38
- Extension D 601/602
- Adapter A 20 x 12.5 DIN 3123
- Torque wrench 0-210 Nm (0-21 kpm)
- Extension for torque wrench
- Turning bar extension
- Ratchet 1/2"
- Ratchet 3/4"
- Extension for 3/4" slider
- Right angle screwdriver 5 DIN 911
- Right angle screwdriver, gunmetal 5 DIN 911

Right angle screwdriver 6 DIN 911
Right angle screwdriver 8 DIN 911
Right angle screwdriver 10 DIN 911
Right angle screwdriver 12 DIN 911
Pin wrench 3/16"
Pliers A 10 DIN 5254
Pliers A 19 DIN 5254
Pliers C 40 DIN 5254
Brush
Handle
Feeler gauge 0.05 - 0.5 mm
Extractor device 401
Pin for loosening the retaining bolts
Ring spanner size 22
Extension for brushes for pipe cooler
Round brush CH 1988/2
Round brush CH 1988/4
Wrench (starter wrench) 27

Name	Figure
1 Description / Use	(The illustrations are examples)
2 Module	
3 Competence class	
4 Order number / Order from ...	

Test case for lube oil and coolant

- 1 Equipment and aids for the lube oil and coolant properties tests
- 2 00 General
- 3 (1)
- 4 1213 0382 / Service Partner



Comprising:	1213 0403	Case (without contents)
		For coolant test
	1213 0395	Test rods for pH value
	1213 0396	Test material for total hardness
	1213 0397	Test material for carbonate hardness
	1213 0398	Test material for chloride content
	1213 0399	Test rod for sulphate content
		For lube oil test
	1213 0384	Complete set, consisting of:
		1213 0385 Instrument for testing water content
		1213 0386 Measuring cylinder
		1213 0387 Suction measuring instrument
		1213 0388 Float vessels (test water content)
		1213 0389 Spare gasket
		1213 0390 Tweezers
		1213 0391 Pipette
	1213 0393	Test tube A (check water content)
	1213 0394	Test tube B (check water content)
	1213 0400	Glass rods for drip sample
	1213 0401	Filter paper for drip sample
	1213 0402	Instrument for viscosity comparison

Name	Figure
1 Description / Use	(The illustrations are examples)
2 Module	
3 Competence class	
4 Order number / Order from ...	

Tool kit

- 1 Standard set
- 2 00 General
- 3 (1)
- 4 1215 0000 / Service Partner

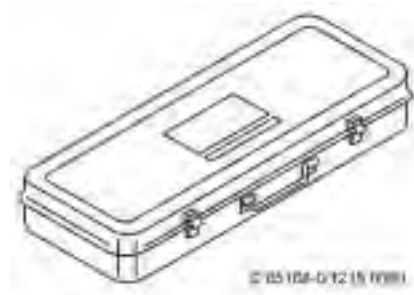

Comprising:	1215 8074	Tool case
	0115 4248	Open end spanner 8 x 10 DIN 3110
	0115 4250	Open end spanner 12 x 14 DIN 3110
	0115 4251	Open end spanner 13 x 17 DIN 3110
	0115 4252	Open end spanner 14 x 15 DIN 3110
	0115 4254	Open end spanner 19 x 22 DIN 3110
	0115 4255	Open end spanner 24 x 27 DIN 3110
	0703 8432	Open end spanner 30 x 32 DIN 3110
	0112 4755	Ring spanner 13 x 17 DIN 838
	0115 4230	Ring spanner 19 x 22 DIN 838
	0115 4231	Ring spanner 24 x 27 DIN 838
	0115 4367	Set of feeler gauges 0.2 – 0.45
	0710 9764	Socket 10 x 12.5 DIN 3124
	0710 9767	Socket 13 x 12.5 DIN 3124
	0110 3966	Socket 14 x 12.5 DIN 3124
	0110 3967	Socket 17 x 12.5 DIN 3124
	0110 3968	Socket 19 x 12.5 DIN 3124
	0110 2416	Socket 22 x 12.5 DIN 3124
	0115 2905	T-handle A 12.5 DIN 3122
	0110 2415	Extension B 12.5 x 250 DIN 3123
	0115 4232	Universal joint C 12.5 DIN 3123
	0110 3385	Screwdriver A 0.8 x 4.0 DIN 5265
	0110 4281	Screwdriver A 1 x 5.5 DIN 5265

Name	Figure
1 Description / Use	(The illustrations are examples)
2 Module	
3 Competence class	
4 Order number / Order from ...	

Acid tester

- 1 For checking the battery fluid density
- 2 13 Electrical system
- 3 (1)
- 4 1215 7944 / Service Partner



Lube oil filter key

- 1 For loosening the lube oil filter cartridge
- 2 08 Lube oil system
- 3 (1)
- 4 1215 8153 / Service Partner

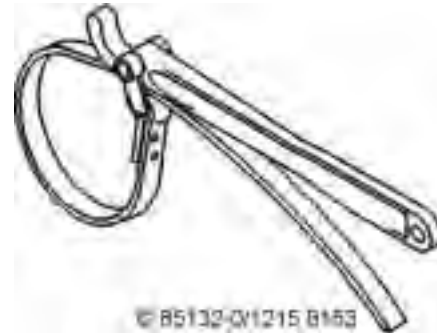

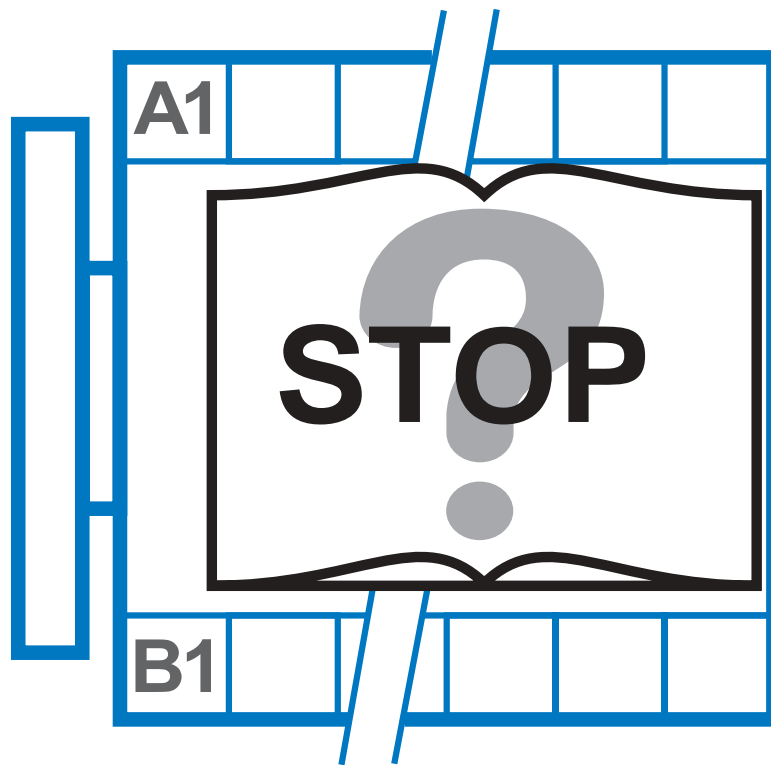



Troubleshooting

The following table is a list of faults which may occur during engine operation and their possible causes. It does not claim to be a full list.

The causes of the faults are listed in ascending order of effort required to localise them.

The tables listed below contain measures which may help to eliminate the fault. If the fault persists even after carrying out the measures, please contact your Service Partner.

Fault table

Fault	Page
Engine fails to start	6 / 4
Engine does not reach the specified output or speed	6 / 4
Engine fires irregularly	6 / 4
Engine "knocks" and runs intermittently.	6 / 5
Engine stops suddenly or is switched off by TEM after a fault	6 / 5
Engine gets too hot or TEM indicates "lack of coolant"	6 / 6
Lube oil pressure too low / TEM "Lube oil pressure too low" or "Lube oil level too low"	6 / 6
Coolant in lube oil	6 / 6
Lube oil in coolant	6 / 7

Troubleshooting remedies

Engine fails to start

TEM message	Possible cause	Remedy
Engine fails to start	Battery flat or defective	Check battery, recharge / renew if necessary
	Starter defective	Check starter, renew if necessary
	Power supply to unit terminal box interrupted	Check cable harness and repair / renew if necessary
	Ignition system defective	Check the ignition system
	Gas stop valves closed	Open gas stop valves
	Gas pipe not bled	Bleed gas line

Engine does not reach the specified output or speed

TEM message	Possible cause	Remedy
Gas pressure	Gas stop valves not fully open	Open the gas stop valves fully / check gas filter and renew if necessary
	too little gas	Check gas pressure
	Air filter soiled	Check air filter, renew if necessary
Gas mixer stop	Gas-air mixture defective (too lean / too rich)	Check regulation of the gas mixer
	No valve clearance	Setting valve clearance

Engine fires irregularly

TEM message	Possible cause	Remedy
Engine misfiring ¹⁾	Ignition control unit defective	Check ignition control unit, renew if necessary
	Ignition coils defective	Check ignition coils, renew if necessary
	Electrode spacing at spark plug too great	Check spark plug, adjust / renew if necessary
	Spark plugs defective	Check spark plugs, renew if necessary
	Pickup (camshaft or control shaft) gap too great / near limit	Check gap and set if necessary

1) The smooth running detector of the TEM system can be used to detect misfiring.

Engine "knocks" and runs intermittently.

TEM message	Possible cause	Remedy
Engine fails to start	Ignition cable defective	Check ignition cable, renew if necessary
	Ignition coils defective	Check ignition coils, renew if necessary
	Pickup (camshaft or control shaft) gap too great / or near limit	Check gap and set if necessary
	Gas pipe not bled	Bleed gas line
	Inlet or outlet valves leaking	Check valves, grind if necessary
	Oil carbon residue on pistons or outlet valves	Clean components

Engine stops suddenly or is switched off by TEM after a fault

TEM message	Possible cause	Remedy
	Ignition failed (cable break)	Check cable harness and repair / renew if necessary
	Ignition control unit defective	Check ignition control unit, renew if necessary
	Pickup (camshaft or control shaft) gap too great / or near limit	Check gap and set if necessary
	Gas supply interrupted	Check gas pipe
	Gas pressure regulator jams	Check gas pressure regulator and repair / renew if necessary
Gas mixer stop lean	Gas pressure too high	Check gas pressure, correct gas pressure at the gas pressure regulator
Overspeed	Speed governor defective	Check speed governor, repair if necessary ¹⁾
Fault cooling water pump	Coolant pump defective (pump shaft broken, bearing defective)	Check coolant pump and repair / renew if necessary
Overtemperature cooling water	Coolant channels in the engine sludged or blocked by scale	Clean the coolant system
Low cooling water	Too little coolant	Check / correct coolant level, find reason for loss of coolant and repair
	Coolant pump losing too much coolant	Check axial sealing rings of the coolant pump, renew if necessary
Lube oil level too low / over-temperature lube oil	Lube oil level too low	Check / correct lube oil level

1) only by authorised experts

Engine gets too hot or TEM indicates "lack of coolant"

TEM message	Possible cause	Remedy
Fault cooling water pump	Coolant pump defective (pump shaft broken, bearing defective)	Check coolant pump and repair / renew if necessary
Overtemperature cooling water	Coolant channels in the engine sludged or blocked by scale	Clean the coolant system
Low cooling water	Too little coolant	Check / correct coolant level, find reason for loss of coolant and repair
	Coolant pump losing too much coolant	Check axial sealing rings of the coolant pump, renew if necessary
	Three-way valve secondary heating circuit defective	Check three-way valve secondary heating circuit, renew if necessary
	Heat transmission primary to secondary poor	Clean sludged elements of the heat transformer

Lube oil pressure too low / TEM "Lube oil pressure too low" or "Lube oil level too low"

TEM message	Possible cause	Remedy
Lube oil filter soiled	Lube oil filter soiled	Replace filter
Lube oil level too low / overtemperature lube oil	Lube oil level too low	Check / correct lube oil level
Lube oil pressure too low	Manifold to lube oil pump soiled	Clean manifold
	Lube oil pump heavily worn	Check lube oil pump, renew if necessary
	Safety valve on the lube oil pump leaking	Check safety valve and repair / renew if necessary
	Lube oil pressure gauge defective	Check lube oil pressure gauge, renew if necessary
	Regulating valve defective	Check regulating valve, repair if necessary*
	Bearing clearance of the crankshaft and con-rod bearings too great (wear)	Check bearing clearances, reposition components if necessary

Coolant in lube oil

TEM message	Possible cause	Remedy
	Cylinder liner seal in crankcase leaking	Remove cylinder liner and reseal, analyse lube oil sample

Lube oil in coolant

TEM message	Possible cause	Remedy
	Lube oil cooler leaking	Check lube oil cooler, renew if necessary

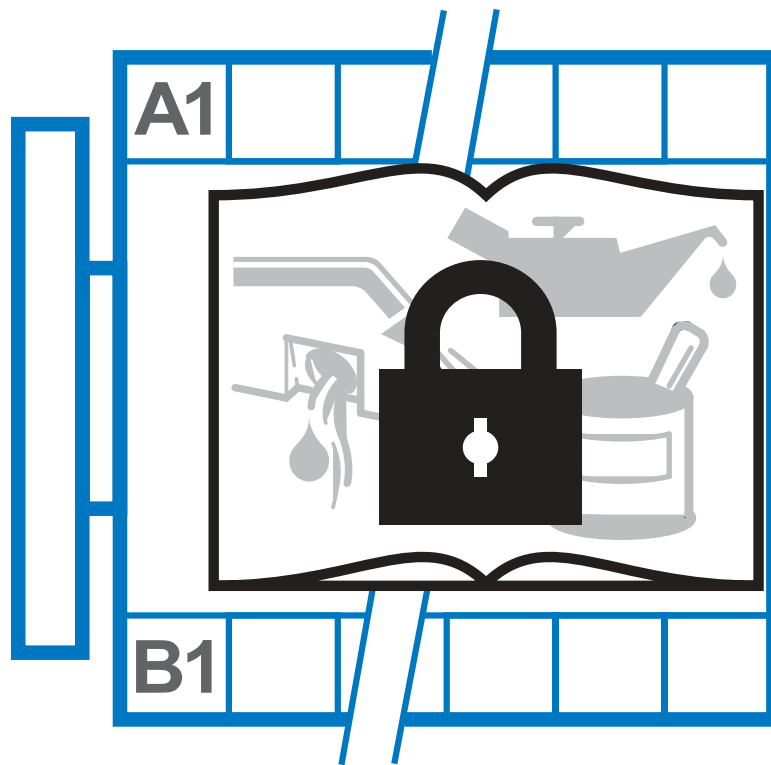



Preservation

Technical Circular TC 0199-99-2116

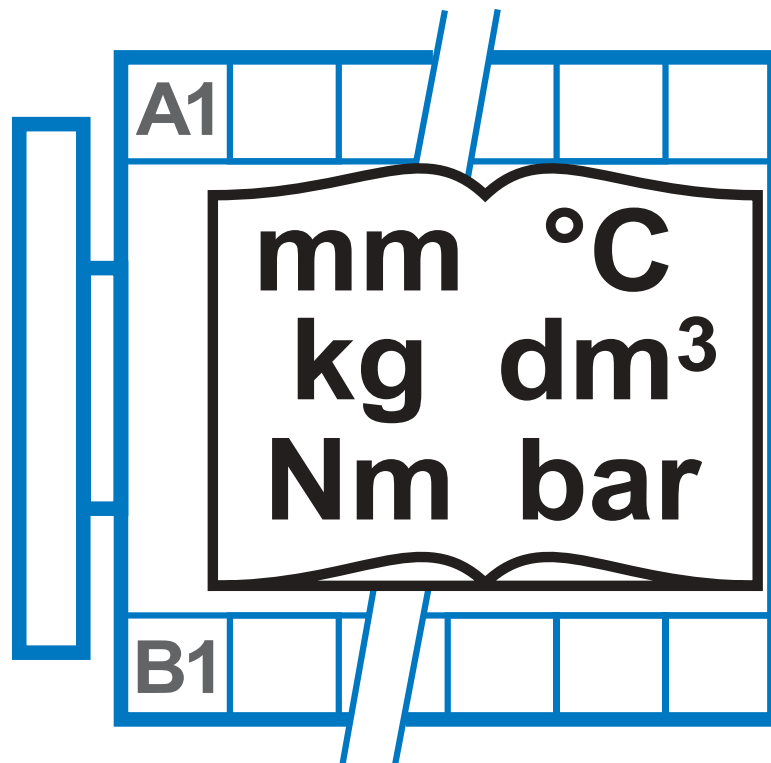



Specifications

Test and setting values

General				
Work procedure	Otto four-stroke engine with four-valve technology			
Mixture charging	Turbocharging with mixture cooling Liquid-cooled mixture cooler			
Cylinder arrangement	V-engine with 90° cylinder angle			
No. of cylinders	12, 16 and 20			
Actuator	V12 and V16 engine	Heinzmann StG 30 - 01		
	V20 engine	Heinzmann StG 2080 - 01		
Combustion gas type	V12 and V16 engine	Gases of gas group 1 and 2		
	V20 engine	Gases of gas group 1		
Efficiency	Gas group 1 - 50Hz	V12 engine	85,5 %	
		V16 engine	85,8 %	
		V20 engine	84,7 %	
	Gas group 2 - 50Hz	V12 engine	87,2 %	
		V16 engine	87,2 %	
		V20 engine	84,9 %	
	Gas group 1 - 60Hz	V12 engine	85,7 %	
		V16 engine	85,8 %	
	Gas group 2 - 60Hz	V12 engine	86,8 %	
		V16 engine	86,9 %	
	Speeds	at 50 Hz		1500 rpm
		at 60 Hz		1800 rpm
Power	Gas group 1 - 50Hz	V12 engine	1050 kW	
		V16 engine	1400 kW	
		V20 engine	2000 kW	
	Gas group 2 - 50Hz	V12 engine	970 kW	
		V16 engine	1294 kW	
		V20 engine	1750 kW	
	Gas group 1 - 60Hz	V12 engine	1050 kW	
		V16 engine	1400 kW	
	Gas group 2 - 60Hz	V12 engine	1050 kW	
		V16 engine	1400 kW	
	Bore	170 mm		
	Stroke	195 mm		

Capacity per cylinder			4.426 dm ³
Total displacement		V12 engine	53.1 dm ³
		V16 engine	70.8 dm ³
		V20 engine	88.5 dm ³
Ignition sequence	V12	A1 B2 A5 B4 A3 B1 A6 B5 A2 B3 A4 B6	
	V16	A1 B2 A6 B5 A8 B7 A3 A7 B6 A4 B8 A2 B3 A5 B1 B4	
	V20	A1 B7 A2 B5 A4 B3 A6 B1 A8 B2 A10 B4 A9 B6 A7 B8 A5 B10 A3 B9	
Dimensions	V12 engine	Length	4,700 mm
		Width	1,800 mm
		Height	2,650 mm
	V16 engine	Length	5,500 mm
		Width	1,800 mm
		Height	2,650 mm
	V20 engine	Length	6,300 mm
		Width	1,750 mm
		Height	2,550 mm
Weights*	V12 engine	Engine	4,200 kg
		Power unit	8,480 kg
	V16 engine	Engine	5,800 kg
		Power unit	10,830 kg
	V20 engine	Engine	7,800 kg
		Power unit	17,580 kg
	Cylinder head, complete		45 kg
	Cylinder liner		16 kg
	Piston, complete		10 kg
	Con rod, complete		15 kg
	Camshaft	V12 engine	44 kg
		V16 engine	56 kg
		V20 engine	48 kg
	Crankshaft with counterweights	V12 engine	511 kg
		V16 engine	452 kg
		V20 engine	611 kg
	Main bearing cover		16 kg
	Oil pan	V12 engine	90 kg
		V16 engine	100 kg
		V20 engine	340 kg
	Flywheel		316 kg
Vibration damper	V20 engine	42 kg	

intercooler without cover	V12 engine	75 kg
	V16 engine	75 kg
	V20 engine	113 kg
Lube oil pump, complete	V12 engine	37 kg
	V16 engine	42 kg
	V20 engine	42 kg

* All data are approximate values

Coolant content	total	V12 engine	139 dm ³
		V16 engine	179 dm ³
		V20 engine	262 dm ³
Coolant temperatures	Engine max.	Inlet / outlet	80 / 92 °C
	with glycol	Inlet / outlet	80 / 92 °C
Intake air temperature	min.		20 °C
	Design		Project-related

Cylinder head

Control times (with valve clearance)	Inlet opens before TDC		12° 45'
	Inlet closes after BDC		26° 45'
	Outlet opens before BDC		49°
	Outlet closes after TDC		13°
Valve clearance compensation		Valve shaft / valve bridge	0.05 mm
Valve clearance	Gas group 1 - 50Hz	Inlet	0.3 mm
		Outlet	0.7 mm
	Gas group 2 - 50Hz	Inlet	0.3 mm
		Outlet	0.9 mm
	Gas group 1 - 60Hz	Inlet	0.3 mm
		Outlet	0.9 mm
	Gas group 2 - 60Hz	Inlet	0.3 mm
		Outlet	1.1 mm

Speed controller

Set Altronic frequency generator for camshaft.

Turn engine until pulse screw is visible.

Turn in frequency generator to stop.

Unscrew 0.75 - 1 turn (270°-360°)

Set Jacquet frequency generator for camshaft.

Turn engine until pulse screw is visible.

Turn in frequency generator to stop.

Turn out 2.25 turns (810°)

Turn out further until the mark is facing in running direction

Set Jacquet frequency generator for flywheel.

Turn in frequency generator to stop.

Turn out 1 turn (360°)

Turn out further until the mark is facing in running direction

Actuator	Heinzmann		Stg 30 - 01
	Control output shaft	Angle of rotation	42 °
		max. torque	28 Nm
		Holding torque	14 Nm
		Throughput time	170 ms
Power consumption	Steady state		1 A
	at load change		3-4 A
	max. current		4.5 A
	limited current		2.5 A
Storage temperature			-55 to +110
Ambient temperature	Standard		-25 to +90
	Special version		-40 to +90
Air humidity			up to 100 %
Type of protection	Housing		IP 44
Weight			12.3 kg

Actuator	Heinzmann		Stg 2080 - 01
	Control output shaft	Angle of rotation	36 °
		max. torque	11 Nm
		Holding torque	5.5 Nm
		Throughput time	60 ms
	Power consumption	Steady state	1 A
		at load change	3-4 A
		max. current	4.5 A
		limited current	2.5 A
	Storage temperature	-55 to +110	
	Ambient temperature	Standard	-25 to +90
		Special version	-40 to +90
	Air humidity	up to 100 %	
	Type of protection	Housing	IP 44
	Weight	6.6 kg	

Fuel system / gas system

Gas pressure of the gas control line* 20 - 100 mbar

* may deviate from the setpoint depending on the system and gas type

Lube oil system

Lube oil content	V12 engine	205 dm ³
	V16 engine	265 dm ³
	V20 engine	1,080 dm ³

Electrical system

Starter (electric)	Supply voltage	24 V	
	Power consumption	V12 engine	9 kW
		V16 engine	15 kW
		V20 engine	18 kW
Starter (compressed air)	Supply pressure	min.	16 bar
		max.	30 bar
	Contents of air bottle	2,000 dm ³	
Battery	Voltage	12 V	
	Capacity	V12 engine	4 x 143 Ah
		V16 engine	4 x 215 Ah
		V20 engine	6 x 215 Ah

Battery acid density	Charge status	Normal	Tropical
	well charged	1.28 kg/l	1.23 kg/l
	semi-charged (re-charge)	1.20 kg/l	1.12 kg/l
	discharged (recharge, renew if necessary)	1.12 kg/l	1.08 kg/l
Spark plug	Electrode gap		0.25 mm

Tightening specifications

General				
Screw connections base frame		according to manufacturer's specifications		
Engine claw to crankcase		M14 x 45/100-12.9	200 Nm	
		M14 x 140 - 10.9	200 Nm	
Engine mounting on engine claw		M16 x 90 - 10.9	220 Nm	
Engine mounting on crankcase		M14 x 40 - 10.9	160 Nm	
Nuts / bolts		8.8	10.9	12.9
Standard values according to H 0385-1	M4	2,5	3,5	4.5 Nm
Screw connection class II	M5	5,0	7,5	8.5 Nm
	M6	8,5	13	15 Nm
	M8	20	30	36 Nm
	M10	42	60	70 Nm
	M12	70	110	120 Nm
	M14	110	170	200 Nm
	M16	180	260	300 Nm
	M18	260	360	420 Nm
	M20	360	500	600 Nm
	M22	480	700	800 Nm
	M24	600	850	1000 Nm
	M27	900	1300	1500 Nm
M30	1200	1700	2000 Nm	
Vibration dampers on pipes		according to manufacturer's specifications		
Cylinder head				
Valve bridge lock nut		M10x1	40 Nm	
Lock nut on rocker arm		M12x1.5	45 Nm	
Cylinder head hood on cylinder head		M8x55 / 85	25 Nm	
Crankcase				
Hatch cover on the crankcase		25 Nm		
Fuel system / gas system				
Cover for gas filter housing		8 Nm		

Lube oil system			
Lube oil filter on console			25 Nm
Pressure limiting valve pre-lube pump	Cap nut		70 Nm
Cooling system			
Coolant pipes	Cup nut	Pipe-Ø 6 mm	35 Nm
		Pipe-Ø 8 mm	45 Nm
		Pipe-Ø 10 mm	60 Nm
		Pipe-Ø 12 mm	75 Nm
	Hollow screws	M10 x 1	18 Nm
		M12 x 1.5	29 Nm
		M14 x 1.5	39 Nm
		M16 x 1.5	49 Nm
Electrical system			
Spark plug on cylinder head			52 Nm

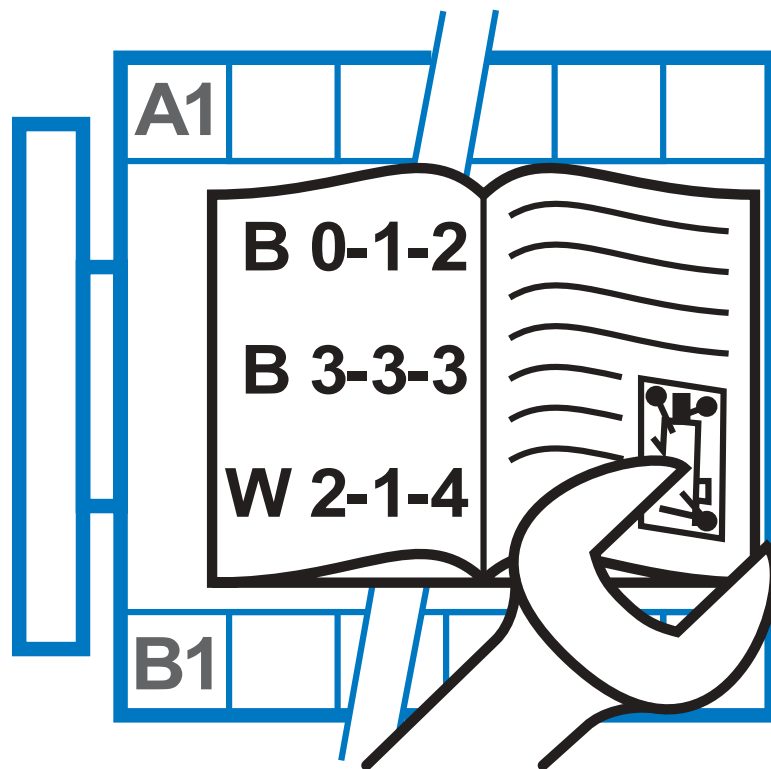



Job cards

Symbol description



Tools

- List of necessary tools and special tools.

**Auxiliary material**

- List of necessary sealing compounds, locking agents, adhesives, lubricants, cleaning agents etc.

**Spare parts**

- List of maintenance and repair parts which must always or sometimes be renewed.

**References**

- List of chapters, job cards, logs etc. to which this job card makes reference.
-



You will find this symbol next to all safety instructions. Follow these meticulously. The attention of operating personnel should be drawn to these safety instructions. In addition, general statutory safety and accident prevention regulations applying in your country must be complied with.



You will find this symbol next to instructions of a general nature.

Follow these meticulously.



Gaskets used in this engine are asbestos-free. Please use appropriate spare parts for maintenance and repair work.

Job card list

The job cards are listed in two lists on the following pages.

- According to job card title
- According to job card number

Auxiliary unit test by means of TEM system (TEM Evolution)	B 0-1-6
Changing lube oil	B 8-1-2
Checking and adjusting inlet and outlet valve clearance	B 1-1-1
Checking percentage of corrosion protection agent or antifreeze in coolant	B 9-1-1
Checking the crankcase pressure	B 3-1-2
Checking the gas pressure of the gas regulating line	B 7-20-1
Checking the speed governor linkage	B 5-4-2
Cleaning the engine	B 0-3-6
Drain water from and fill air bottle (starter air tank)	B 10-7-1
Emptying and filling the cooling system	B 9-0-4
Installing, removing and actuating engine turning gear	B 4-6-1
Lube oil sampling	B 8-1-1
Maintenance crankcase bleeding (Dynapure AS 200 / AS 500 model)	B 3-1-9
Maintenance of crankcase vent (Racor)	B 3-1-9
Overhaul pressure limiting valve of the pre-lube pump	B 8-4-11
Regulations for cutting, grinding, soldering and welding work	B 0-0-4
Removing and installing spark plugs, checking ignition cable	B 13-5-4
Renewing crankcase bleed valve	B 3-1-6
Renewing inspection hole cover gasket	B 3-1-4
Renewing lube oil filter cartridge	B 8-10-4
Renewing the gas filter insert	B 7-21-1
Renewing the suction air intake filter	B 6-3-6
Safety regulations for handling components made of elastomers containing fluoride (e.g. Viton)	B 0-0-3
Servicing the battery	B 13-4-1
Visual inspection of the system	B 0-1-5

B 0-0-3	Safety regulations for handling components made of elastomers containing fluoride (e.g. Viton)
B 0-0-4	Regulations for cutting, grinding, soldering and welding work
B 0-1-5	Visual inspection of the system
B 0-1-6	Auxiliary unit test by means of TEM system (TEM Evolution)
B 0-3-6	Cleaning the engine
B 1-1-1	Checking and adjusting inlet and outlet valve clearance
B 3-1-2	Checking the crankcase pressure
B 3-1-4	Renewing inspection hole cover gasket
B 3-1-6	Renewing crankcase bleed valve
B 3-1-9	Maintenance of crankcase vent (Racor)
B 3-1-9	Maintenance crankcase bleeding (Dynapure AS 200 / AS 500 model)
B 4-6-1	Installing, removing and actuating engine turning gear
B 5-4-2	Checking the speed governor linkage
B 6-3-6	Renewing the suction air intake filter
B 7-20-1	Checking the gas pressure of the gas regulating line
B 7-21-1	Renewing the gas filter insert
B 8-1-1	Lube oil sampling
B 8-1-2	Changing lube oil
B 8-4-11	Overhaul pressure limiting valve of the pre-lube pump
B 8-10-4	Renewing lube oil filter cartridge
B 9-0-4	Emptying and filling the cooling system
B 9-1-1	Checking percentage of corrosion protection agent or antifreeze in coolant
B 10-7-1	Drain water from and fill air bottle (starter air tank)
B 13-4-1	Servicing the battery
B 13-5-4	Removing and installing spark plugs, checking ignition cable

Safety regulations for handling components made of elastomers containing fluoride (e.g. Viton)



References

- Chapter 1, [Rules for disposal](#)
-

General information

Gaskets, round sealing rings and moulded parts are manufactured partly from elastomers containing fluoride (FPM) to withstand high thermal stress.

At unscheduled temperatures above 315°C (caused for example by an engine fire) the material decomposes and forms caustic acids. The residue is tacky and black in appearance.

Proceed as follows if high temperatures have caused damage to gaskets or round sealing rings.

- ‘ Check all gaskets which have suffered from the heat visually.
- ‘ Wear gloves (neoprene).
- ‘ Remove and dispose of residual material
 - see chapter 1, Disposal regulations
- ‘ Destroy clothing which has been contaminated by residue of the gaskets.



Touching the residue material with your hands, even after cooling down, may be damaging to health.

B 0-0-3
TBG 620

Regulations for cutting, grinding, soldering and welding work



References

- Accident prevention regulations

General information

The contractor of cutting, grinding, soldering and welding work must alert the persons enlisted to do the work to the dangers and ensure that the points listed below are observed and complied with.

Persons entrusted with cutting, grinding, soldering and welding work must be familiar with and observe the valid regulations and specifications, especially the rules for accident prevention of the respective national legislations.

The following points must be observed additionally to the specified regulations and specifications.

Electrics / electronics



The following points apply for work where electrical and electronic components may be at risk due to heat or electrical short circuiting.

- Disconnect the battery ground and remove and stow away the battery safely if necessary.
- Pull out the cable set plugs of electrical and electronic components (e.g. TEM switch cabinet, MKS junction box, EMR2-control unit, ignition system, sensors).
- Remove electrical and electronic components in the immediate vicinity of the working area.
- Always connect the ground terminal of the welding gear in the immediate vicinity of the welding point to avoid vagrant currents. Make sure there is a perfect ground connection, remove varnish in the area of the ground terminal if necessary.



Failure to do so can lead to serious damage to the engine electronics.

Sparks / danger of fire

- Keep all inflammable materials away from the danger area.
- Inflammable objects (e.g. cables, compensators) must be covered with non-conductive, non-flammable material or must be removed.
- Sensitive surfaces (e.g. air filter) must be covered with non-conductive and non-flammable material.
- Openings on the engine must be sealed or covered.
- Seal off and cover openings to other work areas.
- Keep a sufficient number of fire extinguishers close by.

Danger of explosion

- Work which could lead to a strong development of heat on gas or fuel pipes and vessels may only be carried out when these have been completely emptied and bled or

flushed.

- Shut off gas pipes and fuel pipes.

Health hazard

- Air well, suck off fumes and dust particles.
- Cordon off the working area during arc welding to protect bystanders against the harmful effects of optical radiation.

Visual inspection of the system



Tools

- Commercially available tools



References

- [B 5-4-2 Checking the speed governor linkage](#)
 - [B 6-3-6 Renewing the suction air intake filter](#)
 - [B 7-20-1 Checking the gas pressure of the gas regulating line](#)
 - [B 7-21-1 Renewing the gas filter insert](#)
 - [B 13-4-1 Servicing the battery](#)
-

General information



Danger of burns !

When working on the hot engine.

The read operating values and liquid levels must be logged with the TEM system.

Daily check

Engine Monitoring System

- Check the display data and control lamps on the switching system.
 - See the operating manual of the engine monitoring system.
- The operating values should be taken from the engine monitoring system and compared with the values in the commissioning log.
 - If values are out of tolerance, find the cause and eliminate it immediately.

Engine

- Check the engine for smooth running and noise.
 - If the engine is not running smoothly or abnormal noise can be heard, the causes must be found and eliminated immediately.

Lube oil circuit

- Check the lube oil circuit and all connected components for leaks.
 - If leaks are detected, find and eliminate the cause immediately.

Coolant circuits

- Check the coolant circuit and all connected components for leaks.
 - If leaks are detected, find and eliminate the cause immediately.

Suction air intake system

- Check the maintenance indicator of the suction intake air filter.

- Renew the suction intake air filter if necessary - see job card B 6-3-6.

Gas system

- Check the gas pressure of the gas control line - see job card B 7-20-1.
 - Renew the gas filter insert if necessary - see job card B 7-21-1.
- Check the gas system and all connected components for leaks.
 - If leaks are detected, find and eliminate the cause immediately.

Compressed air system

- if available - drain water from the air bottle, see job card B 10-7-1.
- Check the compressed air system and all connected components for leaks.
 - If leaks are detected, find and eliminate the cause immediately.

Starter system

- if available - check battery - see job card B 13-4-1.
- Check the electrical component and connectors for corrosion and tight fit.



If the engine is out of operation, the following additional tests can be made.

Speed governor

- Check the easy action of the speed governor, see job card B 5-4-2.

Exhaust gas system

- Check the exhaust gas system and all connected components for firm fit and leaks.
 - Defects which are detected must be eliminated immediately.

Auxiliary unit test by means of TEM system (TEM Evolution)



References

- Operating Manual TEM System

General information



Different test steps of the steps listed below may not be programmed depending on the engine variant and equipment.

The test mode serves for examining the reaction of the aggregate and individual auxiliary aggregates to the commands from the control. It is only possible when the engine is at a standstill and the quick stop is not actuated.

An engine start is not possible in test mode.

The number of auxiliary aggregates offered for testing depends on the engine type and the equipment of the system. Therefore only auxiliary aggregates are offered for testing which have had their parameters released.

If the test result is okay, this is displayed by a green checkmark. If errors occur in the auxiliary aggregate tests (displayed by a red cross) or there is a deviation from the specified values, please contact the DEUTZ Service.

Individual auxiliary aggregates (e.g. starter) can only be activated in touch mode for safety reasons. The auxiliary aggregates only remain switched on for as long as the key is pressed, switching on and off is not possible.

The job can can be used as a copy form.

Conducting the tests

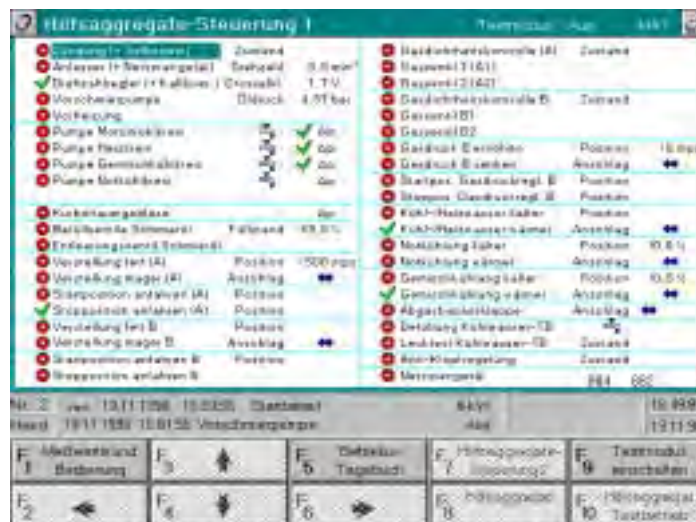

A 1 Mask "Auxiliary unit control 1"

Release auxiliary unit test mode

<ul style="list-style-type: none"> · Switch on manual mode »Measured values and operation« (F1 switch off Auto mode) · Switch on test mode in the mask "Auxiliary aggregates 1" (F9). 					
<p>F8 switch auxiliary unit on and off</p> <p>F10 auxiliary unit touch mode: The auxiliary unit is only switched on for as long as the button is pressed.</p>					
<table border="0" style="width: 100%;"> <tr> <td style="width: 70%;">Test mode</td> <td style="width: 10%; text-align: center;">ok</td> <td style="width: 10%; text-align: center;"><input type="checkbox"/></td> <td style="width: 10%; text-align: center;">nok</td> <td style="width: 10%; text-align: center;"><input type="checkbox"/></td> </tr> </table>	Test mode	ok	<input type="checkbox"/>	nok	<input type="checkbox"/>
Test mode	ok	<input type="checkbox"/>	nok	<input type="checkbox"/>	

Ignition

<ul style="list-style-type: none"> · Switch on ignition (F8) The ignition runs a self-test and reports the result after 10 seconds · Switch off ignition (F8) 					
<p>r red flash Ignition is not OK</p> <ul style="list-style-type: none"> - Check wiring - Check supply to ignition - Check ignition communication - Repeat test <p>U green tick Ignition OK</p>					
<table border="0" style="width: 100%;"> <tr> <td style="width: 70%;">Ignition</td> <td style="width: 10%; text-align: center;">ok</td> <td style="width: 10%; text-align: center;"><input type="checkbox"/></td> <td style="width: 10%; text-align: center;">nok</td> <td style="width: 10%; text-align: center;"><input type="checkbox"/></td> </tr> </table>	Ignition	ok	<input type="checkbox"/>	nok	<input type="checkbox"/>
Ignition	ok	<input type="checkbox"/>	nok	<input type="checkbox"/>	

Speed governor

<ul style="list-style-type: none"> ‘ Switch on speed governor (F8) The speed governor runs a calibration sequence. To do this it runs from 0 % auf 100 % and back. The double valve position is indicated in Volts. ‘ Switch off speed governor (F8) 					
<ul style="list-style-type: none"> ‘ Go to the »Speed governor« mask. Before the final speed governor test: Check the calibration voltage for 0 % and for 100 % (0 % approx. 1.7 V and 100 % approx. 2.9 V) 					
<ul style="list-style-type: none"> ‘ Switch on speed governor test mode (F10) ‘ Set nominal position and check on the actuator (20 %, 50 %, 75 % and 100 %) ‘ Switch off speed governor test mode (F10) ‘ Return to the »Auxiliary units 1« mask 					
<p>Note [V20] Both actuators are calibrated simultaneously in TBG 620 V20.</p>					
<table border="0" style="width: 100%;"> <tr> <td style="width: 70%;">Speed governor</td> <td style="width: 10%; text-align: center;">ok</td> <td style="width: 10%; text-align: center;"><input type="checkbox"/></td> <td style="width: 10%; text-align: center;">nok</td> <td style="width: 10%; text-align: center;"><input type="checkbox"/></td> </tr> </table>	Speed governor	ok	<input type="checkbox"/>	nok	<input type="checkbox"/>
Speed governor	ok	<input type="checkbox"/>	nok	<input type="checkbox"/>	

Pre-lubrication pump engine

<ul style="list-style-type: none"> ‘ Switch on pre-lubrication pump (F8) [TBG 620, TBG 616] pre-lubricate for 20 min [TBG 632] pre-lubricate for 3 min ‘ Check the direction of rotation, ‘ Check oil pressure (1 ... 3 bar) ‘ Leave pre-lubrication pumps switched on 					
<p>Note [632] switch off after 3 min in TBG 632</p>					
<table border="0" style="width: 100%;"> <tr> <td style="width: 70%;">Pre-lubrication pump engine</td> <td style="width: 10%; text-align: center;">ok</td> <td style="width: 10%; text-align: center;"><input type="checkbox"/></td> <td style="width: 10%; text-align: center;">nok</td> <td style="width: 10%; text-align: center;"><input type="checkbox"/></td> </tr> </table>	Pre-lubrication pump engine	ok	<input type="checkbox"/>	nok	<input type="checkbox"/>
Pre-lubrication pump engine	ok	<input type="checkbox"/>	nok	<input type="checkbox"/>	

Pre-lubrication pump generator



The pre-lubrication pump is switched on and off with the menu item »Compartment ventilator colder« Feedback also takes place via this menu item.

- ‘ Switch on pre-lubrication pump (F8)
- ‘ Check the direction of rotation.
- ‘ Check oil pressure.

© 84540-0

X = Holding pressure	Y = Lifting pressure
1 = Pressure set-up for engine start	2 = Start release (approx. 110-120 bar)
3 = Operating pressure (approx. 50-60 bar)	4 = Pressure drop at engine stop

- ‘ Leave pre-lubrication pump switched on

Pre-lubrication pump generator	ok	<input type="checkbox"/>	nok	<input type="checkbox"/>
---------------------------------------	-----------	--------------------------	------------	--------------------------

Starter



Note prior to starter test:

- Ignition switched off
- Pre-lube pump switched on

- ‘ Switch on starter briefly (F10)
- ‘ Check function, speed and oil pressure

In engines with compressed air starter

Set the pre-pressure start air and throttle the starter before actuating it.

Starter	ok	<input type="checkbox"/>	nok	<input type="checkbox"/>
----------------	-----------	--------------------------	------------	--------------------------

Pre-heater

<ul style="list-style-type: none"> • Switch on pre-heater (F8) • Check function • Switch off pre-heater (F8) 					
<p>There is no feedback in the »Auxiliary units 1« mask.</p> <p style="padding-left: 40px;">Bleed the pre-heater first and open all valves</p>					
<table style="width: 100%; border: none;"> <tr> <td style="width: 70%;">Pre-heater</td> <td style="width: 10%; text-align: center;">ok</td> <td style="width: 10%; text-align: center;"><input type="checkbox"/></td> <td style="width: 10%; text-align: center;">nok</td> <td style="width: 10%; text-align: center;"><input type="checkbox"/></td> </tr> </table>	Pre-heater	ok	<input type="checkbox"/>	nok	<input type="checkbox"/>
Pre-heater	ok	<input type="checkbox"/>	nok	<input type="checkbox"/>	

Pump engine cooling circuit

<ul style="list-style-type: none"> • Switch on the engine cooling circuit pump (F8) • Check the direction of rotation. • Observe the differential pressure monitor and set if necessary • Check the differential pressure - wait at least 30 seconds • Switch off the engine cooling circuit pump (F8) 					
<p>r red flash (in front of »Δp« symbol) no differential pressure available</p> <p>U green tick (in front of »Δp« symbol) differential pressure present</p>					
<table style="width: 100%; border: none;"> <tr> <td style="width: 70%;">Differential pressure engine cooling circuit</td> <td style="width: 10%; text-align: center;">ok</td> <td style="width: 10%; text-align: center;"><input type="checkbox"/></td> <td style="width: 10%; text-align: center;">nok</td> <td style="width: 10%; text-align: center;"><input type="checkbox"/></td> </tr> </table>	Differential pressure engine cooling circuit	ok	<input type="checkbox"/>	nok	<input type="checkbox"/>
Differential pressure engine cooling circuit	ok	<input type="checkbox"/>	nok	<input type="checkbox"/>	

Mixture cooling circuit pump

<ul style="list-style-type: none"> • Switch on the mixture cooling circuit pump (F8) • Check the direction of rotation. • Observe the differential pressure monitor and set if necessary • Check the differential pressure - wait at least 30 seconds • Switch off the mixture cooling circuit pump (F8) 					
<p>[MCP]</p> <ul style="list-style-type: none"> • Pump table cooler fan running 					
<p>r red flash (in front of »Δp« symbol) no differential pressure present</p> <p>U green tick (in front of »Δp« symbol) differential pressure present</p>					
<table style="width: 100%; border: none;"> <tr> <td style="width: 70%;">Differential pressure mixture cooling circuit</td> <td style="width: 10%; text-align: center;">ok</td> <td style="width: 10%; text-align: center;"><input type="checkbox"/></td> <td style="width: 10%; text-align: center;">nok</td> <td style="width: 10%; text-align: center;"><input type="checkbox"/></td> </tr> </table>	Differential pressure mixture cooling circuit	ok	<input type="checkbox"/>	nok	<input type="checkbox"/>
Differential pressure mixture cooling circuit	ok	<input type="checkbox"/>	nok	<input type="checkbox"/>	

[HC] heating circuit pump

<ul style="list-style-type: none"> · Switch on the heating circuit pump (F8) · Check the direction of rotation. · Observe the differential pressure monitor and set if necessary · Check the differential pressure - wait at least 30 seconds · Switch off the heating circuit pump (F8) 					
<p>R red flash (in front of »Δp« symbol) no differential pressure present</p> <p>U green tick (in front of »Δp« symbol) differential pressure present</p>					
<table border="0" style="width: 100%;"> <tr> <td style="width: 70%;">Differential pressure heating circuit</td> <td style="width: 10%; text-align: center;">ok</td> <td style="width: 10%; text-align: center;"><input type="checkbox"/></td> <td style="width: 10%; text-align: center;">nok</td> <td style="width: 10%; text-align: center;"><input type="checkbox"/></td> </tr> </table>	Differential pressure heating circuit	ok	<input type="checkbox"/>	nok	<input type="checkbox"/>
Differential pressure heating circuit	ok	<input type="checkbox"/>	nok	<input type="checkbox"/>	

[EC] Emergency cooling circuit pump

<ul style="list-style-type: none"> · Switch on the emergency cooling circuit pump (F8) · Check the direction of rotation. · Observe the differential pressure monitor and set if necessary · Check the differential pressure - wait at least 30 seconds · Switch off the emergency cooling circuit (F8) 					
<p>[ECS]</p> <ul style="list-style-type: none"> · Pump table cooler fan running 					
<p>R red flash (in front of »Δp« symbol) no differential pressure present</p> <p>U green tick (in front of »Δp« symbol) differential pressure present</p>					
<table border="0" style="width: 100%;"> <tr> <td style="width: 70%;">Differential pressure emergency cooling circuit</td> <td style="width: 10%; text-align: center;">ok</td> <td style="width: 10%; text-align: center;"><input type="checkbox"/></td> <td style="width: 10%; text-align: center;">nok</td> <td style="width: 10%; text-align: center;"><input type="checkbox"/></td> </tr> </table>	Differential pressure emergency cooling circuit	ok	<input type="checkbox"/>	nok	<input type="checkbox"/>
Differential pressure emergency cooling circuit	ok	<input type="checkbox"/>	nok	<input type="checkbox"/>	

[only TBG 632] crankcase blower

<ul style="list-style-type: none"> • Switch on crankcase blower (F8) • Check direction of rotation and function • Switch off crankcase blower (F8) 			
<p>LED I/QX...1.12 plug-in card VME 32 I/O does not light</p> <p>»Feedback differential pressure switch crankcase blower« no differential pressure present</p> <p>LED I/QX...1.12 plug-in card VME 32 I/O does not light</p> <p>»Feedback differential pressure switch crankcase blower« differential pressure present</p>			
Differential pressure heating circuit	ok	<input type="checkbox"/>	nok

Filling valves lube oil

<ul style="list-style-type: none"> • Switch on lube oil filling valves briefly (touch mode F10) • Check function 			
<p>Note</p> <p>There is no feedback in the »Auxiliary units 1« mask.</p>			
Filling valves lube oil	ok	<input type="checkbox"/>	nok

[TBG 632] Emptying valve lube oil

<ul style="list-style-type: none"> • Switch on lube oil emptying valves briefly (touch mode F10) • Check function 			
<p>Note</p> <p>There is no feedback in the »Auxiliary units 1« mask.</p>			
Lube oil drain valve	ok	<input type="checkbox"/>	nok

Gas mixer (A)

<ul style="list-style-type: none"> • Switch on the rich setting (F8) <p>If the gas mixer is at the lean stop (indicated by a blue minus sign) the lean stop must disappear after about 50 steps, the number of steps must increase to maximum 3240. Watch the gas mixer to make sure it really does adopt the rich setting</p>					
<ul style="list-style-type: none"> • Switch on the rich setting (F8) • Switch on the lean setting (F8) <p>The number of steps must be reduced until the lean stop is reached (check stop). Watch the gas mixer whether it sets in lean direction.</p>					
<ul style="list-style-type: none"> • Switch off the lean setting (F8) • Go to start position (F8) <p>The gas mixer moves until it has reached the 0 steps position</p>					
<ul style="list-style-type: none"> • Repeat the rich and lean settings • Check the number of steps <p>The same number of steps must be set every time</p>					
<ul style="list-style-type: none"> • Go to stop position (F8) • Go to start position (F8) <p>The gas mixer must adjust in lean direction until it has reached the lean stop (F8). The stepper motor card then calibrates the momentary position to minus start position and then moves the parameterised number of steps to the start position.</p>					
<p>Note</p> <p>The »rich« stop is marked by a blue (+) symbol</p> <p>The »lean« stop is marked by a blue (-) symbol</p> <p>»Intermediate position« is marked by a blue (↔) symbol</p>					
<table border="0" style="width: 100%;"> <tr> <td style="width: 70%;">Gas mixer (A)</td> <td style="width: 10%; text-align: center;">ok</td> <td style="width: 10%; text-align: center;"><input type="checkbox"/></td> <td style="width: 10%; text-align: center;">nok</td> <td style="width: 10%; text-align: center;"><input type="checkbox"/></td> </tr> </table>	Gas mixer (A)	ok	<input type="checkbox"/>	nok	<input type="checkbox"/>
Gas mixer (A)	ok	<input type="checkbox"/>	nok	<input type="checkbox"/>	

Gas mixer (B)

<ul style="list-style-type: none"> • Gas mixer B is tested in the same way as gas mixer A. 					
<table border="0" style="width: 100%;"> <tr> <td style="width: 70%;">Gas mixer (B)</td> <td style="width: 10%; text-align: center;">ok</td> <td style="width: 10%; text-align: center;"><input type="checkbox"/></td> <td style="width: 10%; text-align: center;">nok</td> <td style="width: 10%; text-align: center;"><input type="checkbox"/></td> </tr> </table>	Gas mixer (B)	ok	<input type="checkbox"/>	nok	<input type="checkbox"/>
Gas mixer (B)	ok	<input type="checkbox"/>	nok	<input type="checkbox"/>	

[DK] Gas tightness check (A)

<ul style="list-style-type: none"> • Switch on gas tightness check (A) (F8) • Check function • Switch off gas tightness check (A) (F8) 					
<p>U green tick (after »Status«) in less than 2 seconds Tightness check not successful</p> <p>r red flash (in front of »Δp« symbol) Tightness check not successful</p> <p>U green tick (after »Status«) after 30 seconds Tightness check successful</p>					
<table border="0" style="width: 100%;"> <tr> <td style="width: 70%;">Tightness check</td> <td style="width: 10%; text-align: center;">ok</td> <td style="width: 10%; text-align: center;"><input type="checkbox"/></td> <td style="width: 10%; text-align: center;">nok</td> <td style="width: 10%; text-align: center;"><input type="checkbox"/></td> </tr> </table>	Tightness check	ok	<input type="checkbox"/>	nok	<input type="checkbox"/>
Tightness check	ok	<input type="checkbox"/>	nok	<input type="checkbox"/>	

Gas valve 1 (A1) and 2 (A2)

<ul style="list-style-type: none"> • Switch gas valve 1 (A1) on and off (F10) • Check function 					
<ul style="list-style-type: none"> • Switch gas valve 2 (A2) on and off (F10) • Check function 					
<table border="0" style="width: 100%;"> <tr> <td style="width: 70%;">Gas valve 1 (A1) and 2 (A2)</td> <td style="width: 10%; text-align: center;">ok</td> <td style="width: 10%; text-align: center;"><input type="checkbox"/></td> <td style="width: 10%; text-align: center;">nok</td> <td style="width: 10%; text-align: center;"><input type="checkbox"/></td> </tr> </table>	Gas valve 1 (A1) and 2 (A2)	ok	<input type="checkbox"/>	nok	<input type="checkbox"/>
Gas valve 1 (A1) and 2 (A2)	ok	<input type="checkbox"/>	nok	<input type="checkbox"/>	

[ZG] [DK] Gas tightness check (B)

<ul style="list-style-type: none"> • Switch on gas tightness check (B) (F8) • Check function • Switch off gas tightness check (B) (F8) 					
<p>U green tick (after »Status«) in less than 2 seconds Tightness check not successful</p> <p>r red flash (in front of »Δp« symbol) Tightness check not successful</p> <p>U green tick (after »Status«) after 30 seconds Tightness check successful</p>					
<table border="0" style="width: 100%;"> <tr> <td style="width: 70%;">Gas leak inspection</td> <td style="width: 10%; text-align: center;">ok</td> <td style="width: 10%; text-align: center;"><input type="checkbox"/></td> <td style="width: 10%; text-align: center;">nok</td> <td style="width: 10%; text-align: center;"><input type="checkbox"/></td> </tr> </table>	Gas leak inspection	ok	<input type="checkbox"/>	nok	<input type="checkbox"/>
Gas leak inspection	ok	<input type="checkbox"/>	nok	<input type="checkbox"/>	

Gas valve 1 (B1) and 2 (B2)

·	Switch gas valve 1 (B1) on and off (F10)		
·	Check function		
·	Switch gas valve 2 (B2) on and off (F10)		
·	Check function		
Gas valve 1 (B1) and 2 (B2)		ok	nok

[ZG] Gas pressure regulator B

·	Switch on increase gas pressure B (F8). If the gas pressure regulator is at minus stop (displayed by a blue minus sign), the minus stop must disappear after about 50 steps. The gas pressure regulator then increases the gas pressure until it reaches the plus stop (indicated by a blue plus sign). Watch the gas pressure regulator to make sure it really does set to "higher pressure"		
·	Switch off increase gas pressure B and switch on reduce gas pressure B The number of steps must be reduced until the minus stop is reached (check stop). Watch the gas pressure regulator whether it sets in minus direction.		
·	Switch off reduce gas pressure B and start position gas pressure regulator. Switch on B. The gas pressure regulator B moves until it has reached the 0 steps position		
·	Switch on stop position gas pressure regulator B. The stepper motor card then calibrates the momentary position to minus start position and then moves the parameterised number of steps to the start position.		
Note			
The »minus« stop is marked by a blue (+) symbol			
The »plus« stop is marked by a blue (-) symbol			
»Intermediate position« is marked by a blue (↔) symbol			
Gas pressure regulator B		ok	nok



Test regulating valves

The positioning time of the drive should be within the following limits

DN 32 to 80 = 30 to 60 s

DN ≥ 100 = 40 to 80 s

If the valve runtime deviates too greatly, the regulation may become unstable.

Engine cooling water valve

<ul style="list-style-type: none"> • Switch on the »warmer« setting (F8) Check the setting direction, stop »warm« (–) must be displayed. • Switch off the »warmer« setting (F8) 					
<ul style="list-style-type: none"> • Switch on the »colder« setting (F8) Check the setting direction, stop »cold« (+) must be displayed. • Switch on the »colder« setting (F8) 					
<p>Note</p> <p>After both stops have been moved to, the current valve position in % is displayed</p>					
<p>Note</p> <p>The »warm« stop is marked by a blue (+) symbol</p> <p>The »cold« stop is marked by a blue (–) symbol</p> <p>»Intermediate position« is marked by a blue (↔) symbol</p>					
<table border="0" style="width: 100%;"> <tr> <td style="width: 70%;">Engine jacket water valve</td> <td style="width: 10%; text-align: center;">ok</td> <td style="width: 10%; text-align: center;"><input type="checkbox"/></td> <td style="width: 10%; text-align: center;">nok</td> <td style="width: 10%; text-align: center;"><input type="checkbox"/></td> </tr> </table>	Engine jacket water valve	ok	<input type="checkbox"/>	nok	<input type="checkbox"/>
Engine jacket water valve	ok	<input type="checkbox"/>	nok	<input type="checkbox"/>	

Mixture cooler valve

<ul style="list-style-type: none"> • Switch on the »warmer« setting (F8) Check the setting direction, stop »warm« (–) must be displayed. • Switch off the »warmer« setting (F8) 					
<ul style="list-style-type: none"> • Switch on the »colder« setting (F8) Check the setting direction, stop »cold« (+) must be displayed. • Switch on the »colder« setting (F8) 					
<p>Note</p> <p>After both stops have been moved to, the current valve position in % is displayed</p>					
<p>Note</p> <p>The »warm« stop is marked by a blue (+) symbol</p> <p>The »cold« stop is marked by a blue (–) symbol</p> <p>»Intermediate position« is marked by a blue (↔) symbol</p>					
<table border="0" style="width: 100%;"> <tr> <td style="width: 70%;">Mixture cooler valve</td> <td style="width: 10%; text-align: center;">ok</td> <td style="width: 10%; text-align: center;"><input type="checkbox"/></td> <td style="width: 10%; text-align: center;">nok</td> <td style="width: 10%; text-align: center;"><input type="checkbox"/></td> </tr> </table>	Mixture cooler valve	ok	<input type="checkbox"/>	nok	<input type="checkbox"/>
Mixture cooler valve	ok	<input type="checkbox"/>	nok	<input type="checkbox"/>	

[HC] Heating water

<ul style="list-style-type: none"> · Switch on the »warmer« setting (F8) Check the setting direction, stop »warm« (-) must be displayed. · Switch off the »warmer« setting (F8) 					
<ul style="list-style-type: none"> · Switch on the »colder« setting (F8) Check the setting direction, stop »cold« (+) must be displayed. · Switch on the »colder« setting (F8) 					
<p>Note</p> <p>After both stops have been moved to, the current valve position in % is displayed</p>					
<p>Note</p> <p>The »warm« stop is marked by a blue (+) symbol</p> <p>The »cold« stop is marked by a blue (-) symbol</p> <p>»Intermediate position« is marked by a blue (↔) symbol</p>					
<table border="0" style="width: 100%;"> <tr> <td style="width: 70%;">[HC] Heating water</td> <td style="width: 10%; text-align: center;">ok</td> <td style="width: 10%;"></td> <td style="width: 10%; text-align: center;">nok</td> <td style="width: 10%;"></td> </tr> </table>	[HC] Heating water	ok		nok	
[HC] Heating water	ok		nok		

[EC] Emergency cooler

<ul style="list-style-type: none"> · Switch on the »warmer« setting (F8) Check the setting direction, stop »warm« (-) must be displayed. · Switch off the »warmer« setting (F8) 					
<ul style="list-style-type: none"> · Switch on the »colder« setting (F8) Check the setting direction, stop »cold« (+) must be displayed. · Switch on the »colder« setting (F8) 					
<p>Note</p> <p>After both stops have been moved to, the current valve position in % is displayed</p>					
<p>Note</p> <p>The »warm« stop is marked by a blue (+) symbol</p> <p>The »cold« stop is marked by a blue (-) symbol</p> <p>»Intermediate position« is marked by a blue (↔) symbol</p>					
<table border="0" style="width: 100%;"> <tr> <td style="width: 70%;">[EC] Emergency cooler</td> <td style="width: 10%; text-align: center;">ok</td> <td style="width: 10%;"></td> <td style="width: 10%; text-align: center;">nok</td> <td style="width: 10%;"></td> </tr> </table>	[EC] Emergency cooler	ok		nok	
[EC] Emergency cooler	ok		nok		

[BY] Exhaust bypass valve

<ul style="list-style-type: none"> • Switch on open exhaust bypass valve (F8) • Check setting direction • Switch on open exhaust bypass valve (F8) <p>The stop must be fed back</p>					
<p>Note</p> <p>The stop is marked by a blue (–) symbol</p>					
<table border="0" style="width: 100%;"> <tr> <td style="width: 70%;">Exhaust gas bypass valve</td> <td style="width: 10%; text-align: center;">ok</td> <td style="width: 10%; text-align: center;"><input type="checkbox"/></td> <td style="width: 10%; text-align: center;">nok</td> <td style="width: 10%; text-align: center;"><input type="checkbox"/></td> </tr> </table>	Exhaust gas bypass valve	ok	<input type="checkbox"/>	nok	<input type="checkbox"/>
Exhaust gas bypass valve	ok	<input type="checkbox"/>	nok	<input type="checkbox"/>	

[only TBG 632] Charging pressure regulating valve [waste gate]

<ul style="list-style-type: none"> • Switch on open charging pressure regulating valve (F8) • Check setting direction • Switch off open charging pressure regulating valve (F8) <p>The stop must be fed back</p>					
<p>Note</p> <p>The stop is marked by a blue (–) symbol</p>					
<table border="0" style="width: 100%;"> <tr> <td style="width: 70%;">Charging pressure control valve.</td> <td style="width: 10%; text-align: center;">ok</td> <td style="width: 10%; text-align: center;"><input type="checkbox"/></td> <td style="width: 10%; text-align: center;">nok</td> <td style="width: 10%; text-align: center;"><input type="checkbox"/></td> </tr> </table>	Charging pressure control valve.	ok	<input type="checkbox"/>	nok	<input type="checkbox"/>
Charging pressure control valve.	ok	<input type="checkbox"/>	nok	<input type="checkbox"/>	

Compressor bypass

<ul style="list-style-type: none"> • Switch on open compressor bypass valve (F8) • Check setting direction • Switch off open compressor bypass valve (F8) <p>The stop must be fed back</p>					
<p>Note</p> <p>The stop is marked by a blue (–) symbol</p>					
<table border="0" style="width: 100%;"> <tr> <td style="width: 70%;">Compressor bypass</td> <td style="width: 10%; text-align: center;">ok</td> <td style="width: 10%; text-align: center;"><input type="checkbox"/></td> <td style="width: 10%; text-align: center;">nok</td> <td style="width: 10%; text-align: center;"><input type="checkbox"/></td> </tr> </table>	Compressor bypass	ok	<input type="checkbox"/>	nok	<input type="checkbox"/>
Compressor bypass	ok	<input type="checkbox"/>	nok	<input type="checkbox"/>	

[TBG 632 and KTB] Filling jacket water day tank

<ul style="list-style-type: none"> • Switch on filling jacket water day tank (F8) • Check whether the solenoid valve opens and closes. • Switch off filling jacket water day tank (F8) 					
<table border="0" style="width: 100%;"> <tr> <td style="width: 70%;">Filling jacket water day tank</td> <td style="width: 10%; text-align: center;">ok</td> <td style="width: 10%; text-align: center;"><input type="checkbox"/></td> <td style="width: 10%; text-align: center;">nok</td> <td style="width: 10%; text-align: center;"><input type="checkbox"/></td> </tr> </table>	Filling jacket water day tank	ok	<input type="checkbox"/>	nok	<input type="checkbox"/>
Filling jacket water day tank	ok	<input type="checkbox"/>	nok	<input type="checkbox"/>	

[TBG 632 and KTB] Leak test jacket water day tank

·	Switch on leak test jacket water day tank (F8)		
r	red flash		
	Leak test unsuccessful - find error.		
U	green tick		
	Leak test successful		
Leak test jacket water day tank		ok	nok

[AKR] Anti-knocking governor

·	Switch on anti-knocking governor (F8)		
·	Wait 30 seconds		
·	Switch off anti-knocking governor (F8)		
U	green tick disappears (after 30 seconds)		
	Anti-knocking governor is not OK		
U	green tick after 30 seconds		
	Anti-knocking tick is OK		
Filling jacket water day tank		ok	nok



Go to the "Auxiliary units 2" (F6) mask for the following tests

Reset emergency off module

·	Switch on reset emergency off module (F10)		
	green LED relay -K136 lights up briefly		
·	»Safety chain« flashes (title bar mask) - emergency off module not reset - trouble-shooting		
	»Safety chain« is not displayed (title bar mask)		
	Emergency off module reset		
Emergency off module		ok	nok

Bypass differential pressure monitor

<ul style="list-style-type: none"> • Switch on bypass differential pressure monitor (F8) • Check function • Switch off bypass differential pressure monitor (F8) <p>U after 30 seconds (green tick in front)</p> <p>Bypass differential pressure monitor not successful</p> <p>U green tick</p> <p>Bypass differential pressure monitor successful</p>	ok	<input type="checkbox"/>	nok	<input type="checkbox"/>
Bypass differential pressure monitor				

Request circuit breaker

<ul style="list-style-type: none"> • Switch on request circuit breaker (F8) • Check whether the request is available at the synchronising unit • Switch off request circuit breaker (F8) <p>Note</p> <p>The request is only output by the TEM-Evo system if the safety chain is not faulty.</p>	ok	<input type="checkbox"/>	nok	<input type="checkbox"/>
Request circuit breaker				

[RL] Switch on compartment ventilator flaps

<ul style="list-style-type: none"> • Switch on compartment ventilator flaps (F8) • Check whether the compartment ventilator flaps open • Switch off compartment ventilator flaps (F8) 	ok	<input type="checkbox"/>	nok	<input type="checkbox"/>
compartment ventilator flaps				

[RL] Compartment ventilation graduated switching

<ul style="list-style-type: none"> • Switch on compartment ventilation step 1, 2 (F8) • Check whether the compartment ventilation switches to the selected step • Switch off compartment ventilation step 1, 2 (F8) 	ok	<input type="checkbox"/>	nok	<input type="checkbox"/>
Compartment ventilation step 1, 2				

[RL] Compartment ventilation frequency controlled

<ul style="list-style-type: none"> • Switch on the compartment ventilation »warmer« (F8) • Check function • Switch off the compartment ventilation »warmer« (F8) 					
<ul style="list-style-type: none"> • Switch on the room ventilation »colder« (F8) • Check function • Switch off the room ventilation »colder« (F8) 					
<table border="0" style="width: 100%;"> <tr> <td style="width: 70%;">Room ventilation warmer and colder</td> <td style="width: 10%; text-align: center;">ok</td> <td style="width: 10%; text-align: center;"><input type="checkbox"/></td> <td style="width: 10%; text-align: center;">nok</td> <td style="width: 10%; text-align: center;"><input type="checkbox"/></td> </tr> </table>	Room ventilation warmer and colder	ok	<input type="checkbox"/>	nok	<input type="checkbox"/>
Room ventilation warmer and colder	ok	<input type="checkbox"/>	nok	<input type="checkbox"/>	

[GKS] Mixture table cooler graduated switching

<ul style="list-style-type: none"> • Switch on mixture table cooler step 2, 3 and 4 (F8) • Check whether the fans on the table cooler switch to the selected step • Switch off mixture table cooler step 2, 3 and 4 (F8) 					
<table border="0" style="width: 100%;"> <tr> <td style="width: 70%;">Mixture table cooler step 2, 3 and 4</td> <td style="width: 10%; text-align: center;">ok</td> <td style="width: 10%; text-align: center;"><input type="checkbox"/></td> <td style="width: 10%; text-align: center;">nok</td> <td style="width: 10%; text-align: center;"><input type="checkbox"/></td> </tr> </table>	Mixture table cooler step 2, 3 and 4	ok	<input type="checkbox"/>	nok	<input type="checkbox"/>
Mixture table cooler step 2, 3 and 4	ok	<input type="checkbox"/>	nok	<input type="checkbox"/>	

[GKS] Mixture table cooler frequency controlled

<ul style="list-style-type: none"> • Switch on the mixture table cooler »warmer« (F8) • Check function • Switch off the mixture table cooler »warmer« (F8) 					
<ul style="list-style-type: none"> • Switch on the mixture table cooler »colder« (F8) • Check function • Switch off the mixture table cooler »colder« (F8) 					
<table border="0" style="width: 100%;"> <tr> <td style="width: 70%;">Mixture table cooler frequency controlled</td> <td style="width: 10%; text-align: center;">ok</td> <td style="width: 10%; text-align: center;"><input type="checkbox"/></td> <td style="width: 10%; text-align: center;">nok</td> <td style="width: 10%; text-align: center;"><input type="checkbox"/></td> </tr> </table>	Mixture table cooler frequency controlled	ok	<input type="checkbox"/>	nok	<input type="checkbox"/>
Mixture table cooler frequency controlled	ok	<input type="checkbox"/>	nok	<input type="checkbox"/>	

[ECS] Emergency table cooler graduated switching

<ul style="list-style-type: none"> • Switch on emergency table cooler step 2, 3 and 4 (F8) • Check whether the fans on the table cooler switch to the respective selected step • Switch off emergency table cooler step 2, 3 and 4 (F8) 					
<table border="0" style="width: 100%;"> <tr> <td style="width: 70%;">Emergency table cooler graduated switching</td> <td style="width: 10%; text-align: center;">ok</td> <td style="width: 10%; text-align: center;"><input type="checkbox"/></td> <td style="width: 10%; text-align: center;">nok</td> <td style="width: 10%; text-align: center;"><input type="checkbox"/></td> </tr> </table>	Emergency table cooler graduated switching	ok	<input type="checkbox"/>	nok	<input type="checkbox"/>
Emergency table cooler graduated switching	ok	<input type="checkbox"/>	nok	<input type="checkbox"/>	

[ECS] Emergency table cooler frequency controlled

<ul style="list-style-type: none"> • Switch on the emergency table cooler »warmer« (F8) • Check function • Switch off the emergency table cooler »warmer« (F8) 				
<ul style="list-style-type: none"> • Switch on the emergency table cooler »colder« (F8) • Check function • Switch off the emergency table cooler »colder« (F8) 				
Emergency table cooler frequency controlled	ok	<input type="checkbox"/>	nok	<input type="checkbox"/>

[AVW] Suction intake air pre-heating

<ul style="list-style-type: none"> • Switch on the suction intake air pre-heating »warmer« (F8) • Check function • Switch off the suction intake air pre-heating »warmer« (F8) <p>Note</p> <p>The actuating valve for the flow must be set in »open« direction.</p>				
<ul style="list-style-type: none"> • Switch on the suction intake air pre-heating »colder« (F8) • Check function • Switch off the suction intake air pre-heating »colder« (F8) <p>Note</p> <p>The actuating valve for the flow must be set in »closed« direction.</p> <p>Note</p> <p>The »warm« stop is marked by a blue (+) symbol</p> <p>The »cold« stop is marked by a blue (-) symbol</p> <p>»Intermediate position« is marked by a blue (<->) symbol</p>				
Suction intake air pre-heating	ok	<input type="checkbox"/>	nok	<input type="checkbox"/>

[GKNK] Pump mixture emergency cooling circuit

<ul style="list-style-type: none"> • Switch on the mixture emergency cooling circuit pump (F8) • Check function • Switch off the mixture emergency cooling circuit pump (F8) 				
Mixture emergency cooling circuit	ok	<input type="checkbox"/>	nok	<input type="checkbox"/>

[GKNK frequency controlled] Mixture emergency cooler

· Switch on the mixture emergency cooler »warmer« (F8)				
· Check function				
· Switch off the mixture emergency cooler »warmer« (F8)				
· Switch on the mixture emergency cooler »colder« (F8)				
· Check function				
· Switch off the mixture emergency cooler »colder« (F8)				
Mixture emergency cooler	ok	<input type="checkbox"/>	nok	<input type="checkbox"/>

Cleaning the engine



Auxiliary material

- Cleaning agent
- Drain plugs, covers
- Compressed air



References

- Chapter 4, Aids

General information



Danger of injury !

Only work with the engine at a standstill.

Secure the engine against starting.



Danger of intoxication !

Provided adequate ventilation !

Suck off fumes, do not inhale !



Risk of injury!

Wear protective glasses and gloves!

Preparation

- Switch off the engine and wait for it to cool down.
- Select cleaning agents: see chapter 4, Auxiliary materials.
- Disconnect the battery.
- Remove protective covers.
- Remove heat shields from the exhaust pipes.
- Seal engine openings (e.g. air inlet) or fit water-tight covers.
- Cover electrical and electronic components (e.g. three-phase current generators, starters) so that they are water-tight.



If the engine is partially dismantled, housing openings must be sealed or fitted with water-tight covers.

Cleaning



High pressure cleaning systems may **not** be used:

- Sensitive components (e.g. filters, sensors, rubber bushes, sealing rings, cables) could be damaged.
- Joints and bearings coated with lubricant or grease filled.

-
- Spray engine with cleaning agent.
 - Observe exposure time according to manufacturer instructions.
 - Spray or wash down engine with a powerful water jet.



Repeat if the engine is still not clean enough.

Removed protective covers and heat protection panels must be cleaned separately.

Finishing work



Protective covers and heat protection panels must be dried before replacing. Otherwise there is a danger of fire due to formation of gas or deflagration inside the housing covers and panels.

- Blow out accumulated water with compressed air.
- Remove covers from electrical and electronic components.
- Remove covers and seals from engine openings.
- Dry and install the exhaust pipe heat shields.
- Dry and install the protective covers.
- Connect the battery.

Checking and adjusting inlet and outlet valve clearance



Tools

- Commercially available tools
- Feeler gauge
- Spark-plug wrench
- Torque wrench



Spare parts

- Sealing rings
- poss. shaped gasket for cylinder head cover



References

- [B 4-6-1 Installing, removing and actuating engine turning gear](#)

Technical data

Test and setting values			
Valve clearance compensation		Valve shaft / valve bridge	0.05 mm
Valve clearance	Gas group 1 - 50Hz	Inlet	0.3 mm
		Outlet	0.7 mm
	Gas group 2 - 50Hz	Inlet	0.3 mm
		Outlet	0.9 mm
	Gas group 1 - 60Hz	Inlet	0.3 mm
		Outlet	0.9 mm
	Gas group 2 - 60Hz	Inlet	0.3 mm
		Outlet	1.1 mm
Tightening specifications			
Valve bridge lock nut		M10x1	40 Nm
Lock nut on rocker arm		M12x1.5	45 Nm
Cylinder head hood on cylinder head		M8x55 / 85	25 Nm

General information

Inlet and outlet valves will only form a seal when closed if the specified clearance is available in the valve drive between the camshaft and the valve shaft.

If the valve clearance is too small the valves are only closed briefly or not at all.

This results in a drop in performance for to the subsequent compression loss.

The valve seat and valve head may burn due to overheating. There is also a danger of an engine fire to to flashover in the exhaust or suction intake channel.

If the valve clearance is too great, the valves open later and close earlier.

Because the valves are only fully open briefly, the filling level of the engine drops. Drop in performance is the result.

This also causes considerable wear in the valve control.

Exact setting and observation of the valve clearance prolongs the life and increases the operational reliability of the engine.

A large valve clearance determined in the test is due to wear in the valve drive.

Depending on the difference between the actual value and the reference value, the valve clearance curve of the respective cylinder must be monitored and the cause investigated immediately.

The actual values must be noted in the "Valve clearance actual values table". A copy of the table is enclosed.

Test and setting sequence.

For the valve setting the inlet and outlet valve of the cylinder to be set must be completely closed, i.e. the valve drive must be on the base circle of the cam. This is guaranteed when the cylinder firing 360° KW before the cylinder to be set is in valve overlap, i.e. the outlet valve closes whilst the inlet valve opens.

The setting is made according to the order of ignition, starting with cylinder A1. In the figure below the ignition order, ignition spacings in degrees of crankshaft and the overlap cylinder assigned to every firing cylinder are specified. To determine the right position of the cylinder to be set the assigned overlap cylinder is observed during slow turning. It must be turned until the valves are just overlapping. The whole overlap range of the overlap cylinder is suitable for the valve setting of the firing cylinder.

The whole valve setting can be made with 2 revolutions of the crankshaft (Step 1 and Step 2).

In the schematic engine figure below the position of the firing cylinders and the overlapping cylinders for the first and second crankshaft revolution are shown. The figure only shows the position, the order is determined by the firing order.

12 cylinder engine

Firing angle offset

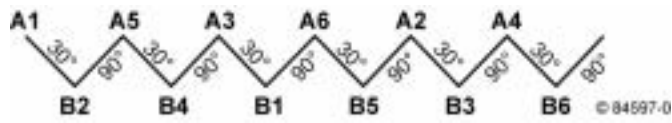

Ignition TDC

A1 B2 A5 B4 A3 B1 A6 B5 A2 B3 A4 B6



Overlap

A6 B5 A2 B3 A4 B6 A1 B2 A5 B4 A3 B1

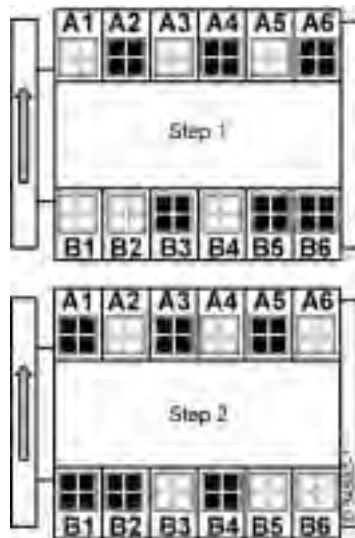

T 1 Test and setting sequence V12.

16 cylinder engine

Firing angle offset

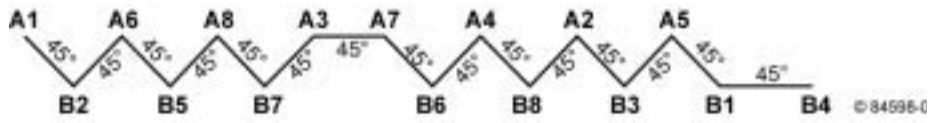

Ignition TDC

A1 B2 A6 B5 A8 B7 A3 A7 B6 A4 B8 A2 B3 A5 B1 B4



Overlap

B6 A4 B8 A2 B3 A5 B1 B4 A1 B2 A6 B5 A8 B7 A3 A7

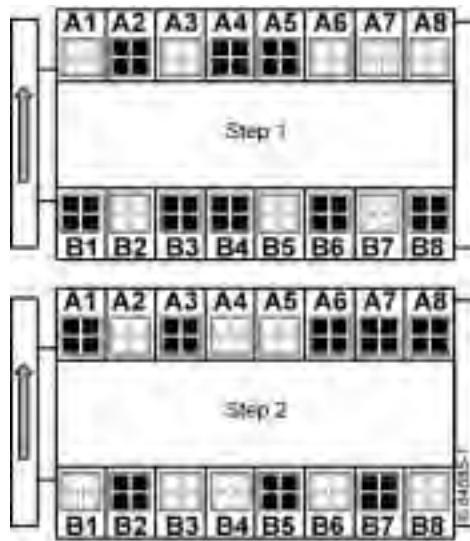

T 2 Test and setting sequence V16

20 cylinder engine

Firing angle offset

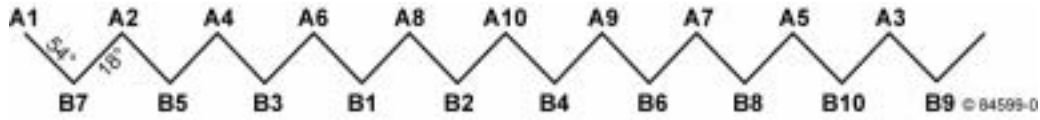

lg. TDC A1 B7 A2 B5 A4 B3 A6 B1 A8 B2 A10 B4 A9 B6 A7 B8 A5 B10 A3 B9



Overl. A10 B4 A9 B6 A7 B8 A5 B10 A3 B9 A1 B7 A2 B5 A4 B3 A6 B1 A8 B2

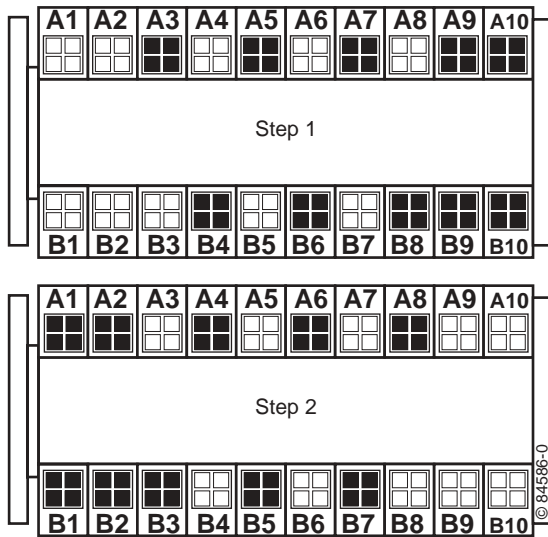

T 3 Test and setting order V20

- Remove cylinder head cover.
 - Pull off the spark plug connector.
 - Unscrew screws and remove the cylinder head cover with gasket.



Only check and set the valve clearance compensation and valve clearance when the engine is cold.

Follow the correct test and setting sequence.

- Install engine turning device, see job card B 4-6-1.
- Turn the engine in direction of rotation until cylinder A1 is in the ignition TDC range.

Checking clearance compensation

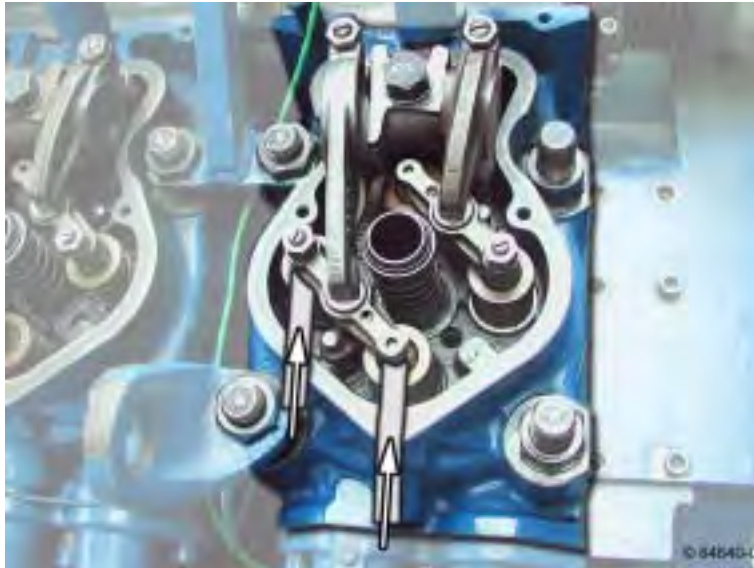

A 1 Checking clearance compensation

- Push feeler gauges between the valve shaft and the valve bridge (arrows).
- Press the toggle lever onto the valve bridge with your finger.
 - The feeler gauges must be removable with little resistance. The valve clearance compensation must be set if not.

Setting clearance compensation

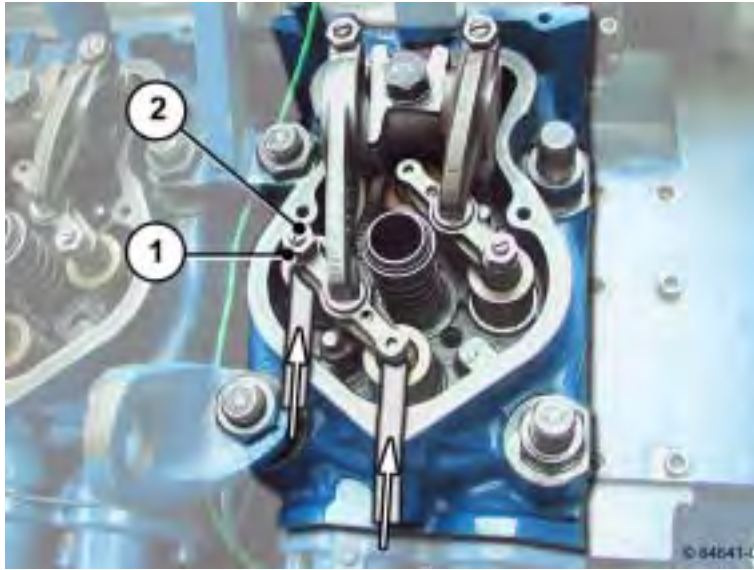

A 2 Setting clearance compensation

- Loosen nut 1.
- Push feeler gauges between the valve shaft and the valve bridge (arrows).
- Press the toggle lever onto the valve bridge with your finger.
- Set the valve clearance compensation with screw 2.
 - The feeler gauges must be removable with little resistance when pressing down the toggle lever at the same time.
- Tighten nut 1.
 - Hold against screw 2.
- Check the valve clearance compensation again with the feeler gauge.
 - Reset the valve clearance compensation in case of deviations.

Checking valve clearance



A 3 Checking valve clearance

- Push feeler gauge between the valve bridge and the toggle lever (arrow).
- The feeler gauge must be insertable and removable with little resistance. The valve clearance must be set if not.

Setting valve clearance

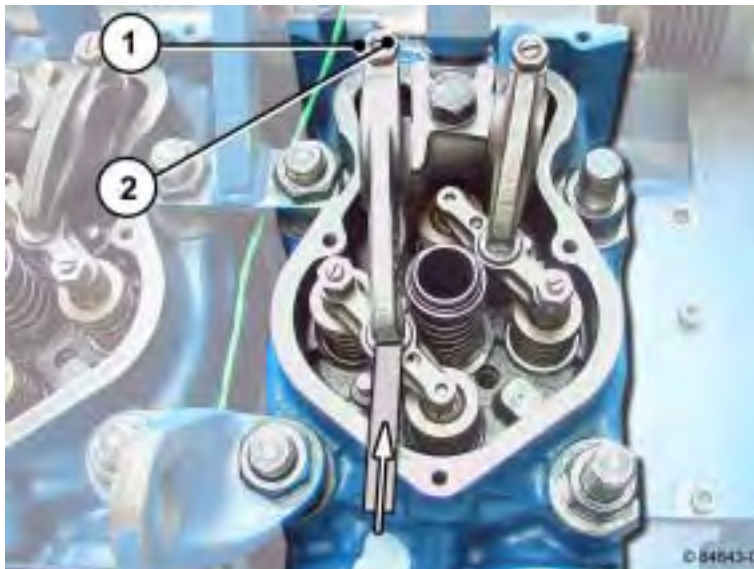

A 4 Valve clearance

- Loosen nut 1.
- Push feeler gauge between the valve bridge and the toggle lever (arrow).
- Set the valve clearance with screw 2.
 - The feeler gauge must be insertable and removable with little resistance.
- Tighten nut 1.
 - Hold against screw 2.
- Check the valve clearance again with the feeler gauge.

- Reset the valve clearance in case of deviations.
- Turn the engine in rotation direction until the next cylinder is in overlap.
- Repeat the test and setting procedure until the valve clearance is set on all cylinders.
- Remove engine turning device, see job card B 4-6-1.
- Attach cylinder head cover.
 - Check the gasket of the cylinder head hood and renew if necessary.
 - Fit the cylinder head covers with gasket and tighten the screws.
 - Plug spark plug connector.

Valve clearance actual values table

The total adjustment time can be determined by the actual value data.

This can enable predictions to be made about the previous wear in the valve drive.

Date	A1		A2		A3		A4		A5		A6		A7		A8		A9		A10		
Cylinder	Valve	In	Out	In	Out	In	Out	In	Out	In	Out	In	Out	In	Out	In	Out	In	Out	In	Out
Date	B1		B2		B3		B4		B5		B6		B7		B8		B9		B10		
Cylinder	Valve	In	Out	In	Out	In	Out	In	Out	In	Out	In	Out	In	Out	In	Out	In	Out	In	Out

Date	A1		A2		A3		A4		A5		A6		A7		A8		A9		A10		
Cylinder	Valve	In	Out	In	Out	In	Out	In	Out	In	Out	In	Out	In	Out	In	Out	In	Out	In	Out
Date	B1		B2		B3		B4		B5		B6		B7		B8		B9		B10		
Cylinder	Valve	In	Out	In	Out	In	Out	In	Out	In	Out	In	Out	In	Out	In	Out	In	Out	In	Out

Date	A1		A2		A3		A4		A5		A6		A7		A8		A9		A10		
Cylinder	Valve	In	Out	In	Out	In	Out	In	Out	In	Out	In	Out	In	Out	In	Out	In	Out	In	Out
Date	B1		B2		B3		B4		B5		B6		B7		B8		B9		B10		
Cylinder	Valve	In	Out	In	Out	In	Out	In	Out	In	Out	In	Out	In	Out	In	Out	In	Out	In	Out

T 4 Table of actual valve clearance values (over all series)

Checking the crankcase pressure



References

- [B 3-1-6 Renewing crankcase bleed valve](#)
 - [B 3-1-9 Maintenance of crankcase vent \(Racor\)](#)
-

General information

The crankcase pressure is checked by the TEM system with the engine running.

It depends on the installation site and height of the engine. The appropriate value must be taken from the commissioning log.

If the specified setpoint is not reached, the crankcase bleed valve must be serviced, see job card B 3-1-9.

B 3-1-2
TBG 620

Renewing inspection hole cover gasket



Tools

- Commercially available tools
- Scraper



Spare parts

- Gasket for inspection hole cover

Technical data

Tightening specifications

Hatch cover on the crankcase

25 Nm

General information



Danger of injury !

Only work with the engine at a standstill.

Secure the engine against starting.

Removing/installing the inspection hole cover

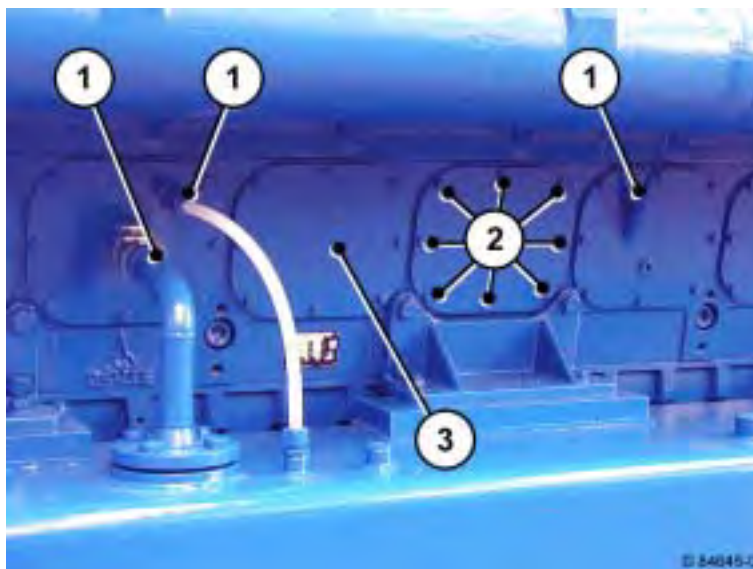

A 1 Inspection hole cover

- Remove line 1 if necessary.
- Unscrew screws 2.
- Remove inspection hole cover 3 with gasket.
- Clean the sealing surface.
- Mount inspection hole cover 3 with gasket.
- Tighten screws 2.

· Mount line 1 if necessary.

Renewing crankcase bleed valve



Tools

- Commercially available tools



Spare parts

- Crankcase bleed valve



References

- [B 3-1-2 Checking the crankcase pressure](#)

General information

The number of crankcase bleed valves installed depends on the engine.

The removal and installation example describes one crankcase bleed valve. For multiple crankcase bleed valves proceed appropriately.



Danger of injury !

Only work with the engine at a standstill.

Secure the engine against starting.

Removing crankcase bleed valve



A 1 Crankcase bleed valve

- Loosen hose clips 1 and remove bleed hose 2.
- Loosen tightening clamp 3.
- Remove crankcase bleed valve 4 from above.

Installing crankcase bleed valve

- Insert crankcase bleed valve 4 from above.



Note installation position of the bleed connection.

- Tighten tightening clamp 3.
- Push on bleed hose 2 and tighten hose clips 1.



After renewing the crankcase bleed valve the crankcase pressure should be checked, see job card B-3-1-2.

Maintenance of crankcase vent (Racor)



Tools

- Commercially available tools



Auxiliary material

- Diesel fuel



Spare parts

- Filter element (with O-seals)
- Base insert, if required

General information

The crankcase vent must be maintained when

- the maintenance intervals have been reached,
- the red indicator button is fully visible in the maintenance indicator.



Cleaning the filter elements is not permissible.



Observe the regulations for disposal !

Collect operating materials and dispose of properly according to national regulations.

Dismantling crankcase vent

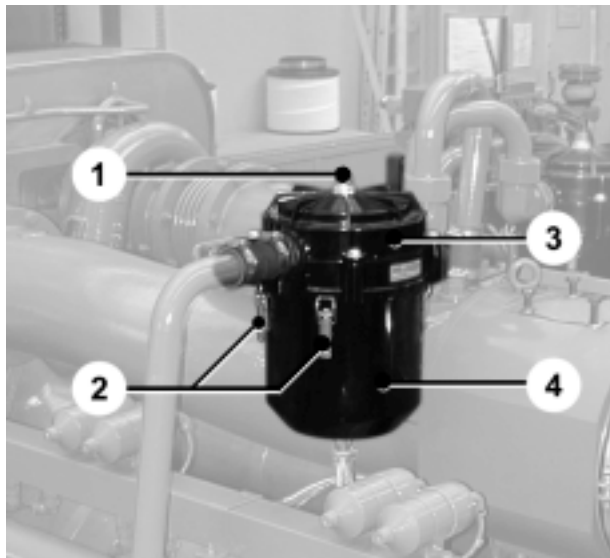

A 1 Crankcase vent Racor

- Open locks 2 and remove the container 4 carefully from the bottom.
 - There may be lube oil in the container.
- Pull filter element 5 from upper section of filter 3.



- Remove base insert 6 from the container 4.

If a base insert is not fitted, this must be retrofitted.

- Clean components with diesel fuel, check and renew if necessary.

Assembling crankcase vent

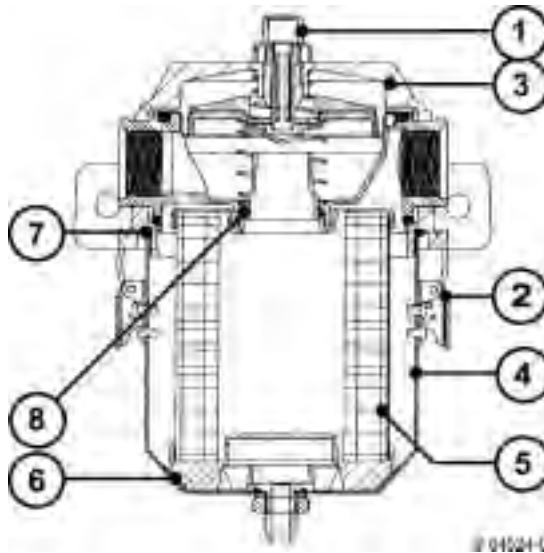

A 2 Filter (cross-sectional diagram)

- If present, check oil outlet and non-return valve for free passage.
- Check the diaphragm of the non-return valve for damage.
- Check all parts of the crankcase vent (e.g. hoses, rubber parts of the connecting and discharge lines) visually, renew if necessary.
- Insert new O-seal 7 in upper section of filter 3.
- Insert new filter element 5 with new O-seal 8 in filter top section 3.
- Install base insert 6 in container 4.



Note installation position.

- Wet the new filter element with lube oil.
- Position container 4 and close locks 2.

Check drain hose

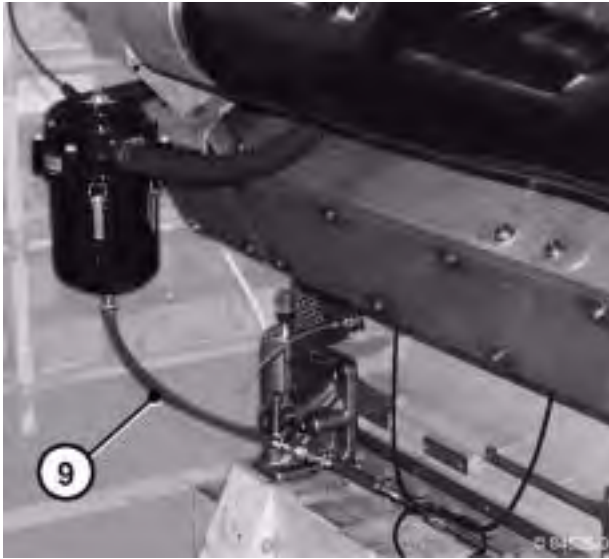

A 3 Crankcase vent Racor

- Check the condition and laying of the flexible drain hose 9 and correct if necessary.



The drain hose must be laid without tension and free from chafing.

Make sure it is far enough away from hot parts.

Resetting the maintenance indicator

- Unscrew cap of maintenance indicator 1.
- Push in the red indicator button.
- Mount and tighten cap.

Instructions for putting (returning) the system into operation



Depending on the design, back absorption through the oil drainage pipe can be prevented by a return valve, a siphon trap or an oil outlet pipe that ends below the oil level (submerged pipe). Before operating for the first time, the siphon trap must be filled with oil. Where there are separate collectors with submerged pipes, a check must be made to ensure that the pipe is actually below the oil level. If necessary, top up the oil in the collector until there is a sufficient amount.

B 3-1-9
TBG 620

Maintenance crankcase bleeding (Dynapure AS 200 / AS 500 model)



Tools

- Commercially available tools
- Special tools available from:
 - Umwelt Technik 99 AG, Sunnehof, CH-8493 Saland, Switzerland
- Assembly tool, order no. 909-190500
- Disassembly tool, order no. 909-190501
- Vibration measuring instrument for imbalance check



Spare parts

- Filter insert
- Basic filter
- Filter disk
- Aluminum grille
- Cover seal
- Engine gaskets

Technical data

Test and setting values

Imbalance of the drum maximum at 50 Hz, 2,810 rpm	7.0 mm/s
Imbalance of the drum maximum at 60 Hz, 3,340 rpm	8.0 mm/s

General information

The sucked in air/oil mixture is spun and accelerated by a rotating drum so strongly that the micro-fine oil mist particles form small droplets and are separated from the air in the rotating filter drum by the sieving and inertia effect.

The oil recycled in such a way flows back through the outlet in the machine room or oil tank .



Danger of injury !

Only work with the engine at a standstill.

Secure the engine against starting.



Risk of injury!

Disconnect the electric motor from the power supply when working on the crankcase bleeding.

Remove filter insert and basic filter

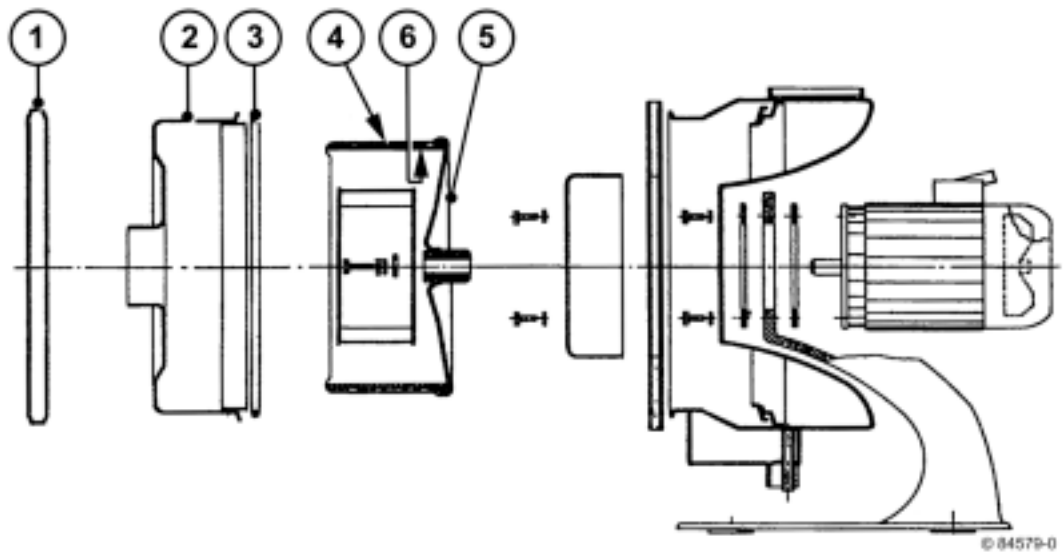

A 1 AS 500 filter insert and basic filter

- Loosen clamping ring 1.
- Remove housing cover 2 with gasket 3.



Danger of imbalance!

Mark the interface of the filter insert 4 in the drum 5

- Remove filter insert.
- Check basic filter 6 for soiling and renew if necessary.



The drum 5 may become imbalanced when the basic filter 6 is changed.

Balancing of the drum is absolutely essential.

Install filter insert and basic filter

- Insert filter insert 4.
 - Pay attention to the mark.
- Fit housing cover 2 with gasket 3.
- Close clamping ring 1.
- Check crankcase bleeding for leaks and perfect functioning.

Remove filter disk with aluminum grille.

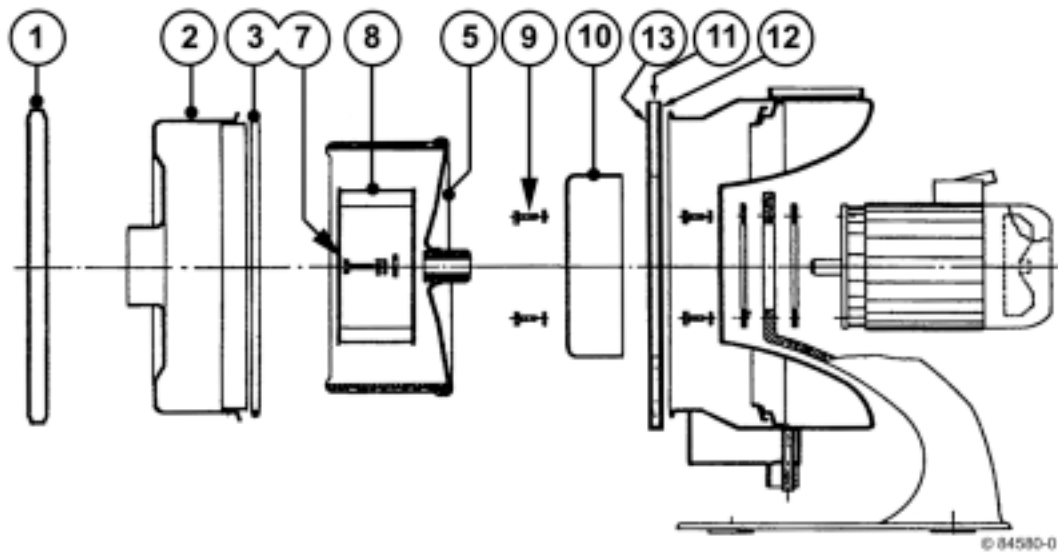

A 2 AS 500 filter disk with aluminum grille

- Loosen clamping ring 1.
- Remove housing cover 2 with gasket 3.
- Unscrew screws 7 and remove turbowheel 8.
- Pull drum 5 off the electric motor shaft with the disassembly tool.
- Unscrew screws 9 and remove retaining drum 10.
- Remove filter disk 11 and aluminum grille 12.
- Check wire grille 13, renew if necessary.

Install filter disk with aluminum grille.

- Insert wire grille 13, aluminum grille 12, filter disk 11 and retaining drum 10 and tighten screws 9.
- Push drum 5 up to the stop on the electric motor shaft with the assembly tool.
- Fit on turbo wheel 8 and tighten screws 7.
- Fit housing cover 2 with gasket 3.
- Close clamping ring 1.
- Check crankcase bleeding for leaks and perfect functioning.

B 3-1-9
TBG 620

Installing, removing and actuating engine turning gear



Tools

- Commercially available tools
 - Engine turning device if necessary
-

General information

If no engine turning device is available, the engines can be turned with the bar (order number 0216 3939) on the flywheel after removing the protective covers.



Always turn the engine in the direction of rotation to avoid damage.



Danger of injury !

Only work with the engine at a standstill.

Secure the engine against starting.

Using the engine turning device



The turning device 1 is spring-loaded for safety reasons.

To turn the engine, press in the hexagon with toothed wheel and turn.

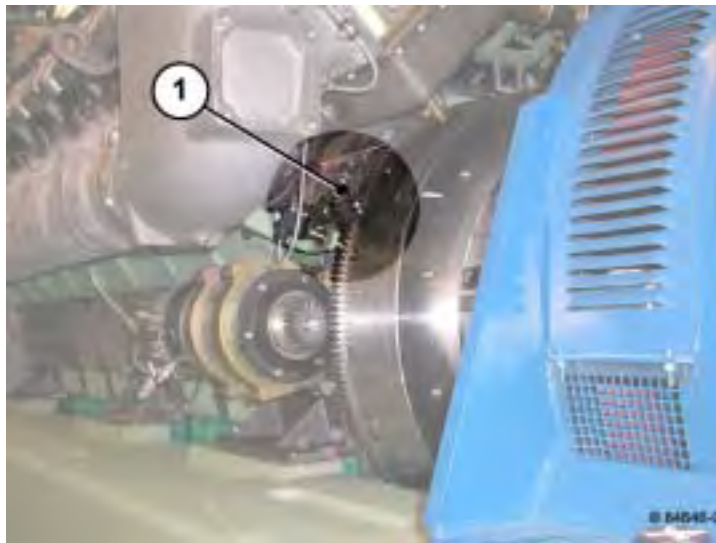

A 1 Installation example engine turning device

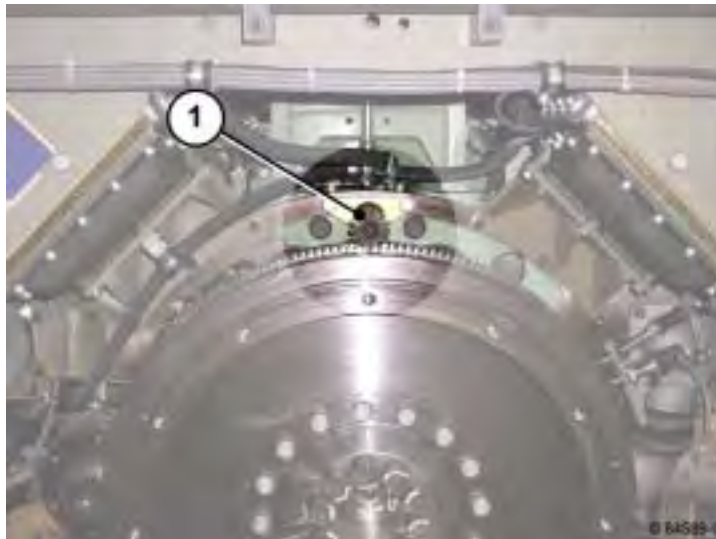

A 2 Installation example engine turning device

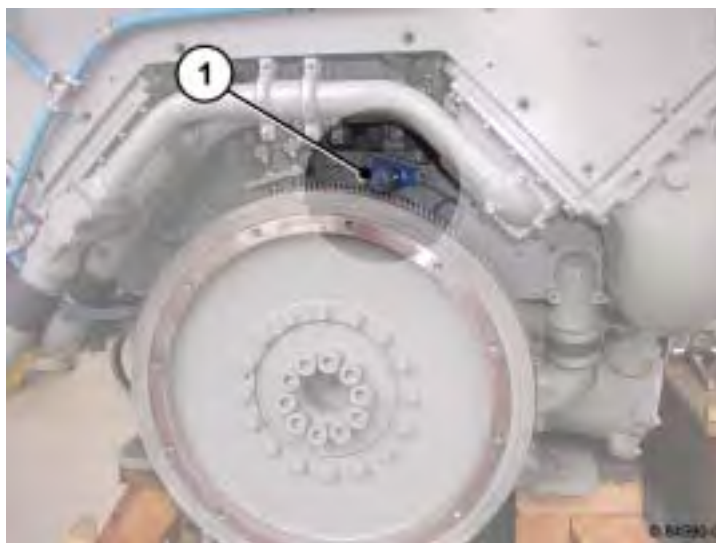

A 3 Installation example engine turning device

Checking the speed governor linkage



Tools

- Commercially available tools



Auxiliary material

- Lubricant, see chapter 4, Aids

General information



Danger of injury !

Only work with the engine at a standstill.

Secure the engine against starting.

Check speed governor linkage, V12 and V16 engines



A 1 Speed governor linkage

- Press the lever 1 to full load stop.



An even resistance must be felt when pressing, lubricate the joints and repeat the test if necessary.

- Move the connecting rod 2 in the direction of the arrow and checked the joint heads for clearance.



If the uneven resistance can still be felt, this indicates a defect in the actuator or the throttle valve.

If the joint heads are not free of clearance, they can be renewed.

Please contact your DEUTZ Power Systems Service if this is the case.

Check speed governor linkage, V20 engines

The V20 engine is equipped with two actuators the output shafts of which act directly on the rotary disk valves.

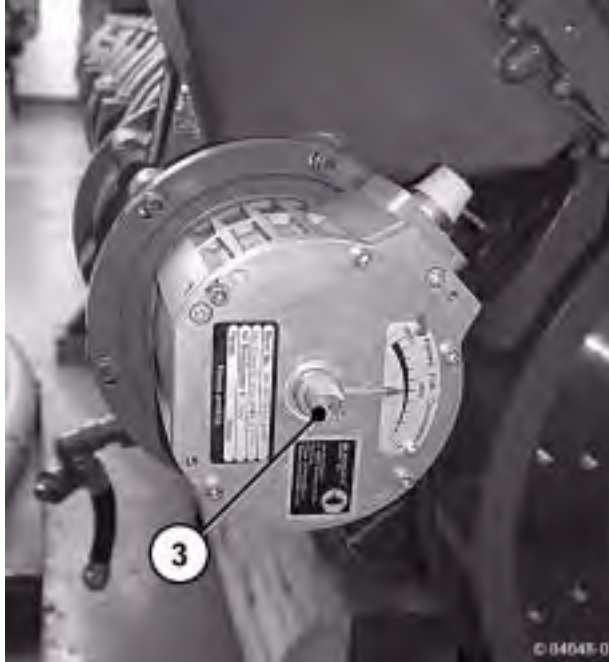

A 2 Speed governor actuator V20

- Turn shaft 3 to full load stop.



An even resistance must be tangible when turning.

If the uneven resistance can still be felt, this indicates a defect in the actuator or the rotary disk valve.

Please contact your DEUTZ Power Systems Service if this is the case.

Renewing the suction air intake filter



Tools

- Commercially available tools



Spare parts

- Suction air intake filter

General information



Danger of injury !

Only work with the engine at a standstill.

Secure the engine against starting.

Renew the suction air intake filters when

- the maintenance interval has been reached,
- the maintenance indicator on the air filter displays this even after the engine is switched off.

Temporary appearance of the display in the maintenance indicator during operation of the engines does not indicate a soiled air filter.

Removing filter insert, V12 and V16 engines

Removing filter insert

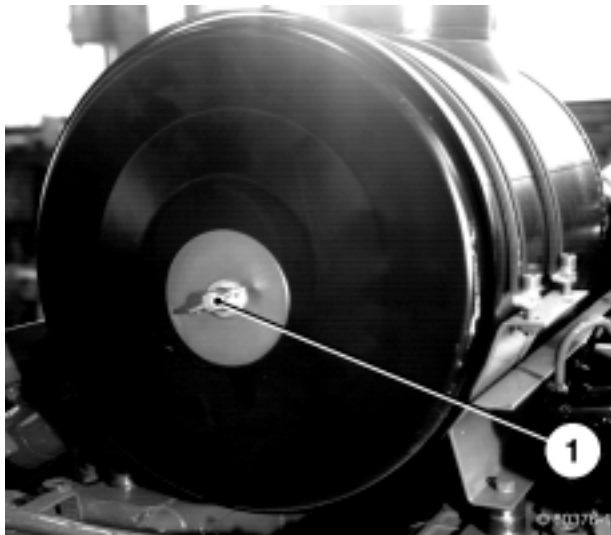

A 1 Air filter housing

- Unscrew wing nut 1.
- Remove cover from the air filter housing.

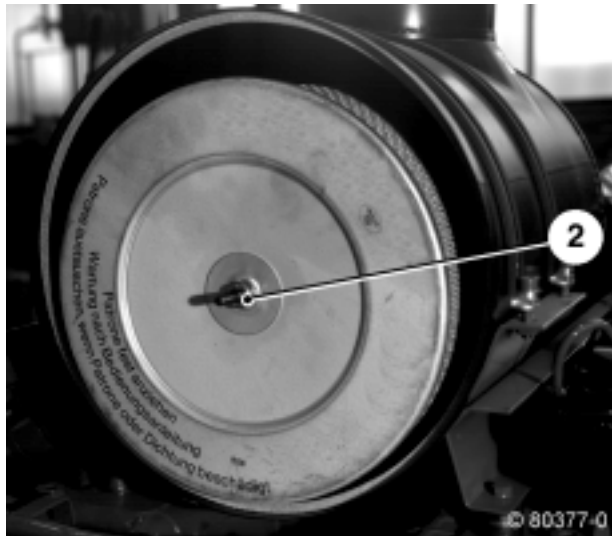

A 2 Air filter insert

- Unscrew nut 2.
- Remove suction air intake filter.
- Clean the inside of the air filter housing with a cloth.

Fitting filter insert

- Insert new suction air intake filter.
- Tighten nut 2.
- Mount cover on air filter housing.
- Tighten wing nut 1.

Removing and installing the filter insert, V20 engines

Removing filter insert

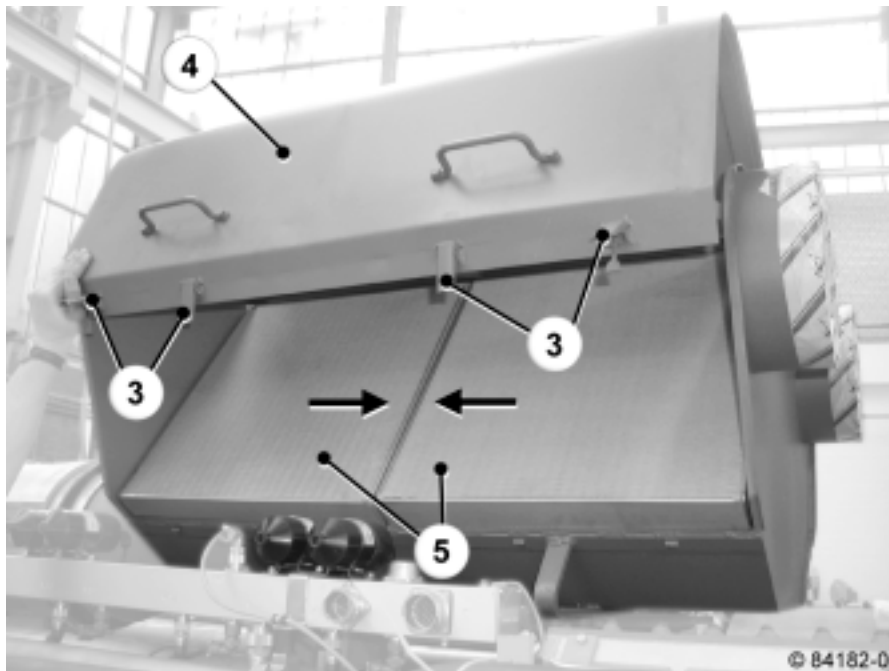

A 3 Air filter housing V20

- Open catches 3 and lift up cover 4 of the air filter housing.
- Remove suction air intake filter 5.
- Clean the inside of the air filter housing with a cloth.

Fitting filter insert

- Insert new suction air intake filter and push together (arrow).



Note the flow direction of the suction air intake filter.

- Close the cover of the air filter housing and lock catches 3.

Checking the gas pressure of the gas regulating line



References

- [B 7-21-1 Renewing the gas filter insert](#)

Technical data

Test and setting values

Gas pressure of the gas control line* 20 - 100 mbar

* may deviate from the setpoint depending on the system and gas type

General information

The gas pressure in the gas regulator line can be read from the pressure gauge. This is supplied by the pre-pressure regulator line and depends on the gas type and quality.

Checking the gas pressure in the gas regulator line

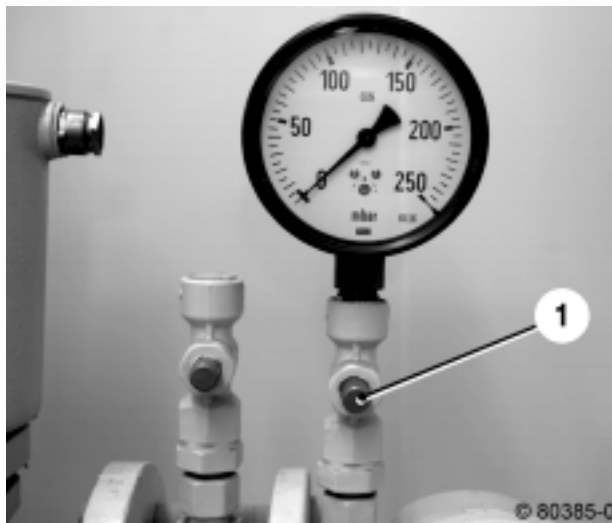

A 1 Pressure gauge gas regulating line

Press the button 1 and read the gas pressure.



If the prescribed value is not reached, the gas filter insert must be renewed, see job card B 7-21-1.

Renewing the gas filter insert



Tools

- Commercially available tools



Spare parts

- Gaskets
- Filter insert



References

- [B 7-20-1 Checking the gas pressure of the gas regulating line](#)

Technical data

Tightening specifications

Cover for gas filter housing	8 Nm
------------------------------	------

General information



Caution, explosion hazard !

The ventilation system should be switched on before carrying out any work on the gas line.

Smoking and the use of naked flames is prohibited.

Removing the gas filter insert

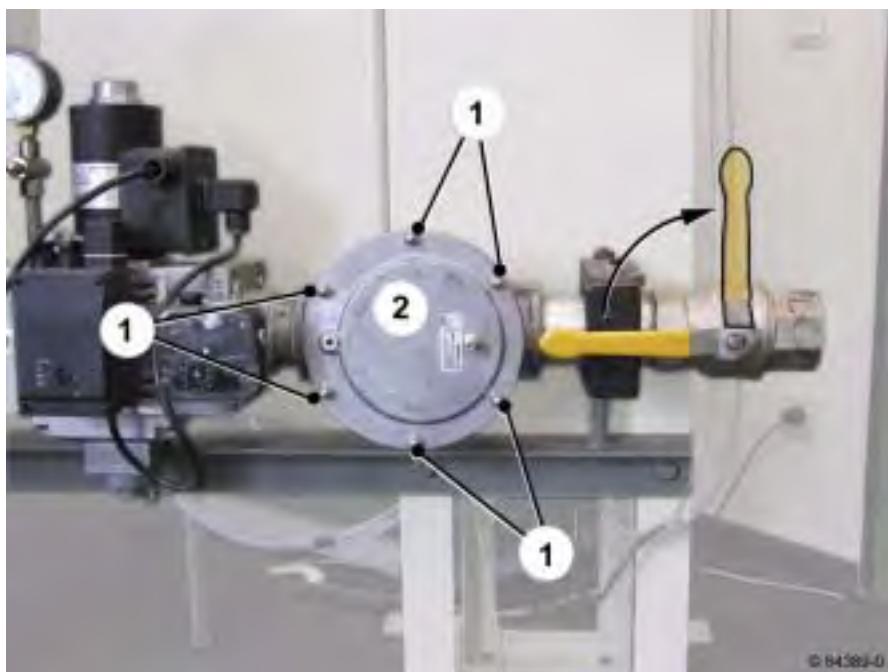

A 1 Gas regulator line

- Close the ballcock (arrow) to shut off the gas intake.

- Loosen nuts 1 and remove the cover from the gas filter housing 2.

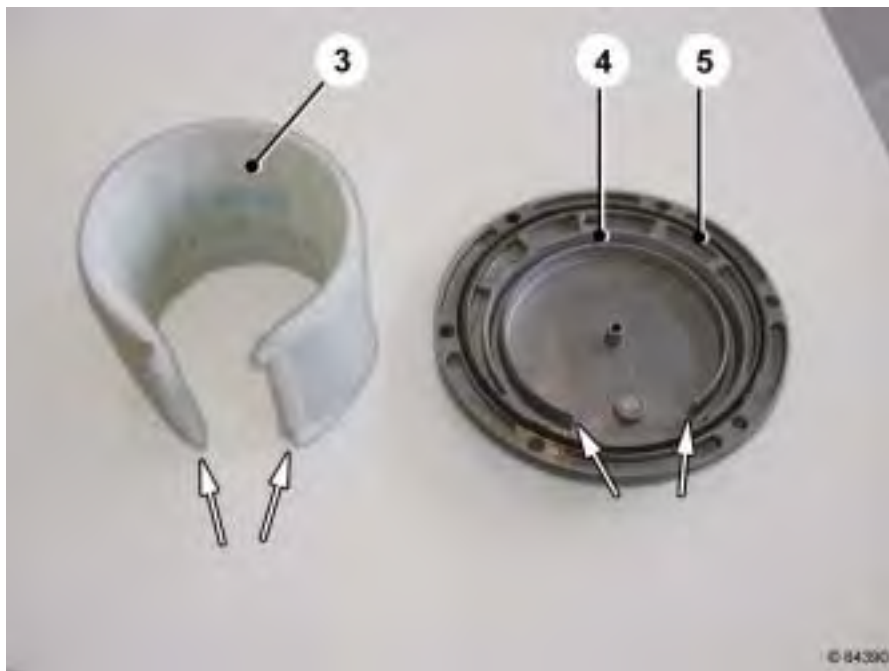

A 2 Filter insert/cover

- Remove filter insert 3 from cover 4.
- Clean cover and gas filter housing.

Installing the gas filter insert

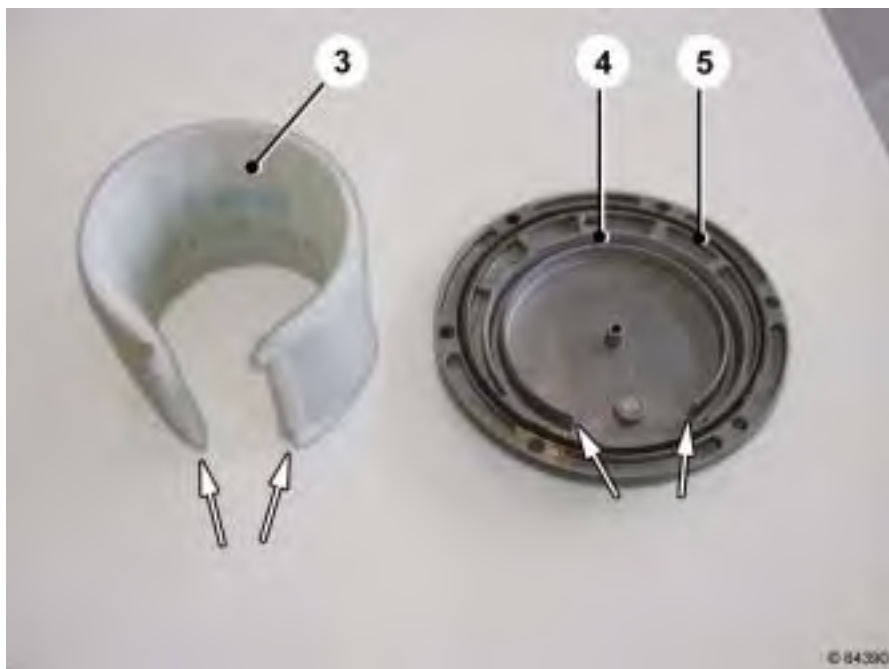

A 3 Filter insert/cover

- Renew seal 5.
- Mount new filter insert 3 on cover 4.



Note the position of the filter insert on the cover (arrow).



A 4 Cover with filter insert

- Place cover with filter insert 6 into gas filter housing.



Note the position of the filter insert on the gas filter housing (arrows).

- Turn on nuts and tighten diagonally.
- Open ballcock to restore gas supply.
- Check the cover and gas filter housing for leaks.
 - To do this, spray the cover with leak search spray or soap suds and watch for formation of bubbles.

Lube oil sampling



Tools

- Commercially available tools
- Lube oil sample container



Auxiliary material

- Lube oil according to operating media specifications, chapter 4, [Aids](#)

General information

Trouble-free operation and resistance to undue wear depend to a great extent on the lube oil condition. Checking the lube oil is therefore one of the most important maintenance jobs.

An analysis should be carried out by the lube oil manufacturer because a detailed examination is only possible in the laboratory. If no other possibilities are available, DEUTZ Power Systems will carry out the analysis for reimbursement of expenses.

The necessary data for lube oil analysis are:

- Lube oil brand and type
- Reading shown on the operating hours counter
- Lube oil consumption since last sample.

The lube oil must be renewed if the result of the analysis is negative.

The lube oil sample must be taken from the lube oil circuit while the engine is running and at operating temperature.



Risk of scalding !

When working with hot operating materials.

Lube oil tap

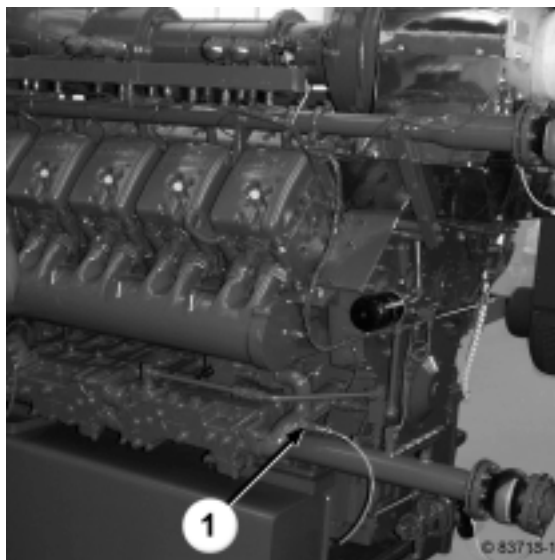

A 1 Position of the lube oil tapping valve

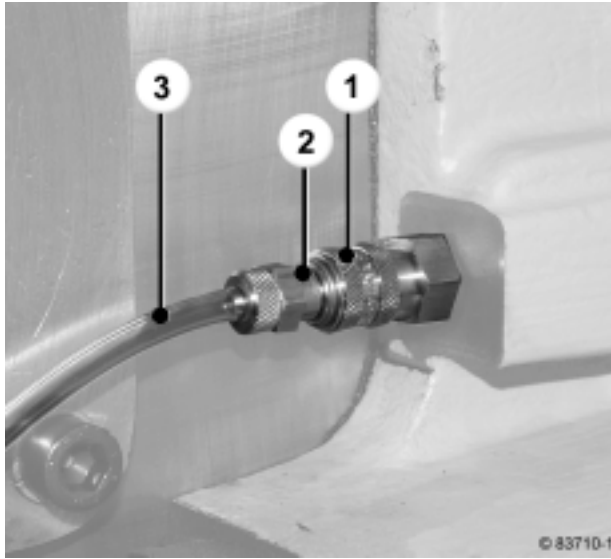

A 2 Assembly of the tapping valve for the lube oil sampling

- Start engine and run up to operating temperature (oil temperature $>80^{\circ}\text{C}$).
- Press coupling piece 2 with hose pipe 3 into the lube oil tap valve 1 until it snaps in.



Danger of burns !

After snap-in of the coupling, lube oil emerges immediately at about 4 bar and 100°C .

- Drain the required amount of lube oil into the lube oil sample container.
- Release the lube oil tap valve 1 and pull off the coupling 2 with hose pipe 3.

Changing lube oil



Tools

- Commercially available tools



Spare parts

- Lube oil according to operating media specifications



References

- Chapter 4, [Operating media](#)
 - Operating Manual TEM System
 - Technical Circular TC 0199-99-2105
-

General information

The lube oil change is performed in connection with the TEM System.

Depending on the system version, there is an option for "remote oil change" which enables control of two solenoid valves for automatic switching between the pre-lubrication and pumping modes. Oil can then be changed via modem.

The lube oil change should be performed on the warm engine (lube oil temperature at least 80°C).



Danger of injury !

Only work with the engine at a standstill.

Secure the engine against starting.



Risk of scalding !

When working with hot operating materials.



Observe the regulations for disposal !

Collect operating materials and dispose of properly according to national regulations.

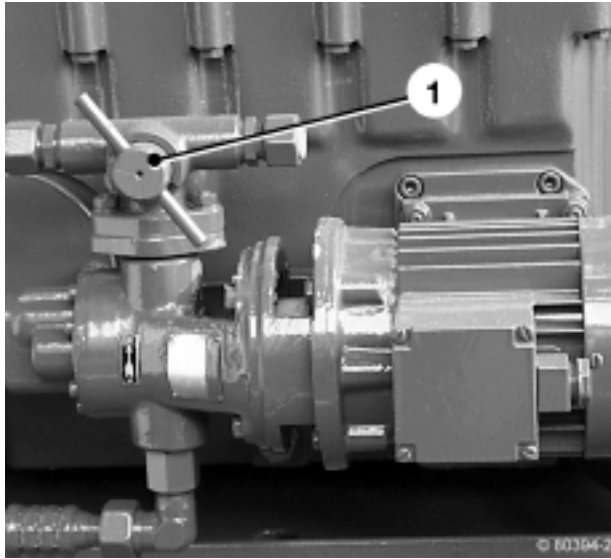

A 1 Dreiwegehahn Vorschmierpumpe

Pump off lube oil

- ‘ Switch the three-way valve 1 on the pre-lubrication pump so that the used oil can be pumped out.
- ‘ In the TEM system
 - Select the menu item "Service menu"
 - Select the "Oil change" menu item.
 - Select the "Pump out oil" menu item - (pumping starts and ends after the time programmed in TEM).



If the oil pan is not empty after the programmed time (pre-lubrication pump switches off), the pumping process must be continued with the "Pump out oil" menu item.

If the oil pan is empty before the programmed time (pre-lubrication pump sucks in air), the pre-lubrication pump can be shut off with the "Oil pan empty" menu item.

- ‘ Switch the three-way valve 1 on the pre-lubrication pump back to engine mode.



The lube oil filter cartridges should always be renewed when changing the lube oil, see job card B 8-10-4.

Pour in lube oil

- In the TEM system
 - Select the "Refill" menu item - (fresh oil filling begins).



The filling process is controlled automatically by the TEM system.

On reaching the filling volume the filling process is ended automatically by the lube oil level switch.

- At the end of fresh oil filling
 - Select the "Pre-lubricate" menu item - (pre-lubrication process begins).



The pre-lube process lasts about 20 minutes, the engine cannot be started beforehand.

Overhaul pressure limiting valve of the pre-lube pump



Tools

- Commercially available tools
- Torque wrench
- Depth gauge



Spare parts

- Sealing rings (DIN 7603-A 21x26-Cu)
- Poss. control piston
- Poss. compression spring

Technical data

Tightening specifications

Pressure limiting valve pre-lube pump	Cap nut	70 Nm
---------------------------------------	---------	-------

General information



Danger of injury !

Only work with the engine at a standstill.

Secure the engine against starting.

Dirt particles may collect on the control piston of the pre-lube pump's pressure limiting valve. The control piston is then no longer fully in contact with the piston seat and leaks. Some of the pumped engine oil is taken off directly due to this leak. The oil pressure required for pre-lubrication is then no longer achieved.

Overhaul pressure limiting valve of the pre-lube pump

Dismantle the pressure limiting valve

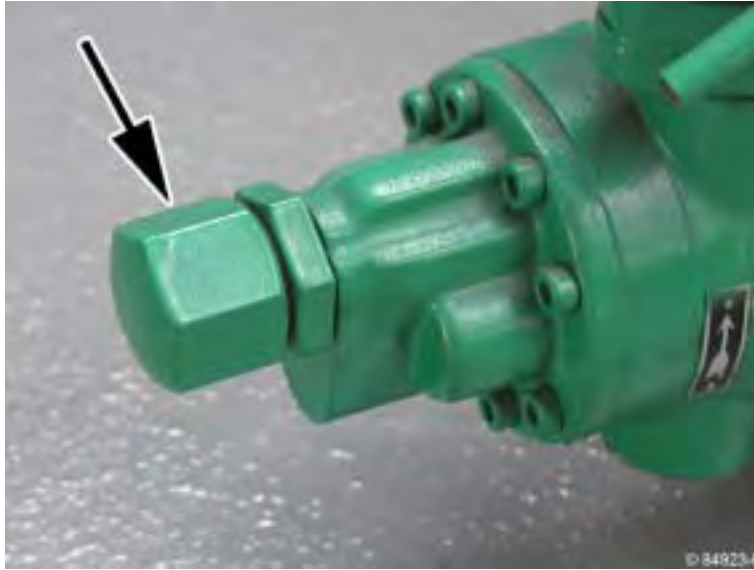

A 1 84923-0 cap nut

- Unscrew the cap nut.



A 2 84929-0 Measure setting dimension

- Determine dimension X with caliper gauge and note for later installation.
 - measured from the top of the setting screw to the lock nut.



A 3 84930-0 Set oil pressure

- Loosen lock nut and unscrew setting screw.

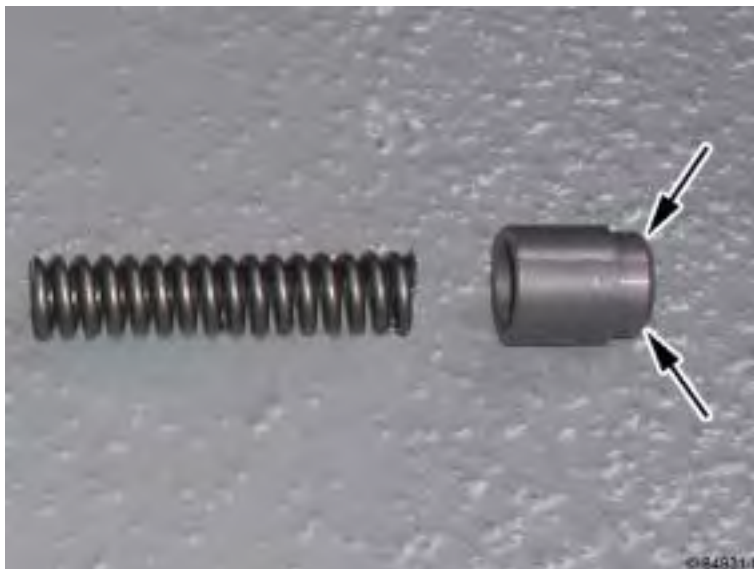

A 4 84931-Inside parts

- Remove compression spring and control piston.
- Clean the seat on the control piston (arrows) and in the housing of the pressure control valve.



Check components (compression spring, control piston) for wear, renew if necessary.

Assemble pressure limiting valve

- Insert control piston and compression spring.
- Renew sealing ring and screw in setting screw with lock nut.

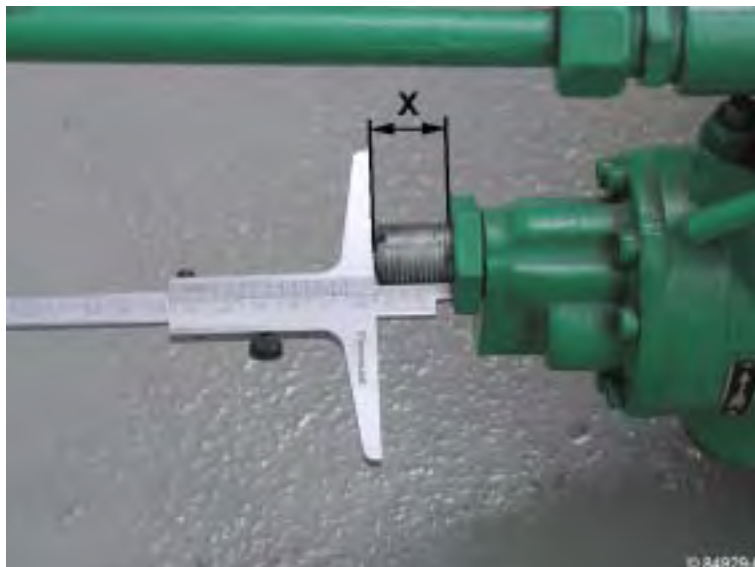

A 5 84929-0 Measure setting dimension

- Turn in setting screw to dimension X.



The dimension X determined when removing must be retained otherwise the set oil pressure will be changed.



A 6 84930-0 Set oil pressure

- Tighten lock nut.



Hold at the setting screw.

After tightening the lock nut, check the dimension X again with the depth measuring appliance, loosen the lock nut again if necessary and reset the dimension X.

- Renew sealing ring and tighten cap nut.

Renewing lube oil filter cartridge



Tools

- Commercially available tools
- Strip key



Auxiliary material

- Container for waste oil



Spare parts

- Lube oil according to operating media specifications
- Lube oil filter cartridge



References

- Chapter 4, [Operating media](#)
- Operation manual TEM System

Technical data

Lube oil system

Lube oil filter on console

27 Nm

General information



Danger of injury !

Only work with the engine at a standstill.

Secure the engine against starting.



Risk of scalding !

When working with hot operating materials.



Observe the regulations for disposal !

Collect operating materials and dispose of properly according to national regulations.

Removing the lube oil filter cartridge



A 1 Remove the lube oil filter

- Unscrew and remove the lube oil filter cartridge with commercially available strip key.
 - Collect the remaining oil which runs out.



When unscrewing the lube oil cartridge fine plastic chips are produced when the catch is released. These chips do not get into the lube oil system and pose no danger.

Install the lube oil filter cartridge



A 2 Install the lube oil filter

- Clean the seal surface of the filter block.
- Wet the gasket of the new lube oil filter cartridge slightly with lube oil.
- Fit lube oil filter cartridge to filter block and tighten.

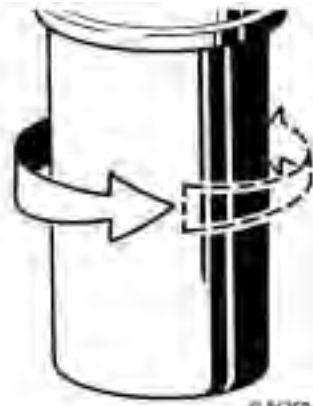

A 3 Tighten the lube oil filter

· Check lube oil filter cartridge for leaks.

- build up oil pressure with pre-lubrication pump to do so.

Emptying and filling the cooling system



Tools

- Commercially available tools



Auxiliary material

- Collecting vessel for coolant



Spare parts

- Gaskets



References

- Chapter 4, [Operating media](#)
 - [B 9-1-1 Checking percentage of corrosion protection agent or antifreeze in coolant](#)
-

General information

For various work, e.g. on the cylinder head, crankcase, heat exchanger and pipes, the coolant must be partially or totally drained.

If no antifreeze is added, the coolant must be drained totally from the engine and the add-on parts when shutting down the engine for a longer time and in case of frost.



Danger of burns !

Corrosion protection is not a fire hazard in the hardened state.



Danger of injury !

Only work with the engine at a standstill.

Secure the engine against starting.



Observe the regulations for disposal !

Collect operating materials and dispose of properly according to national regulations.

Emptying the cooling system

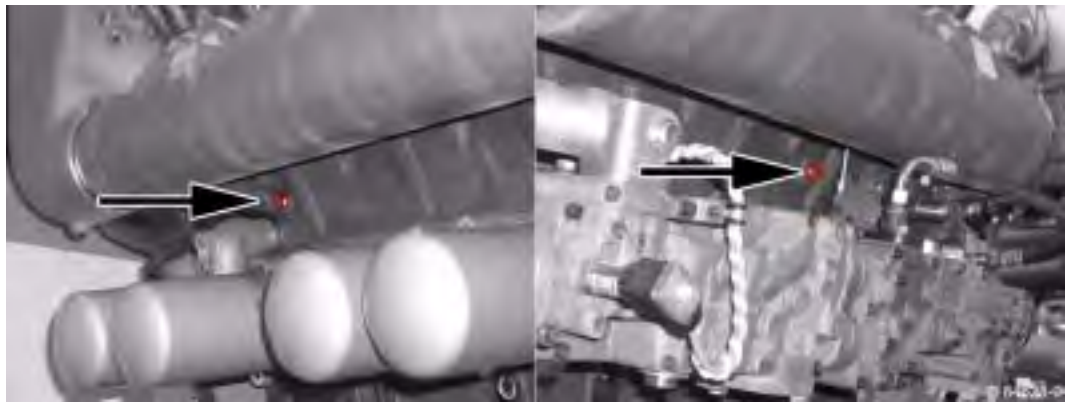

A 1 Beispiel Ablasstopfen Kurbelgehäuse

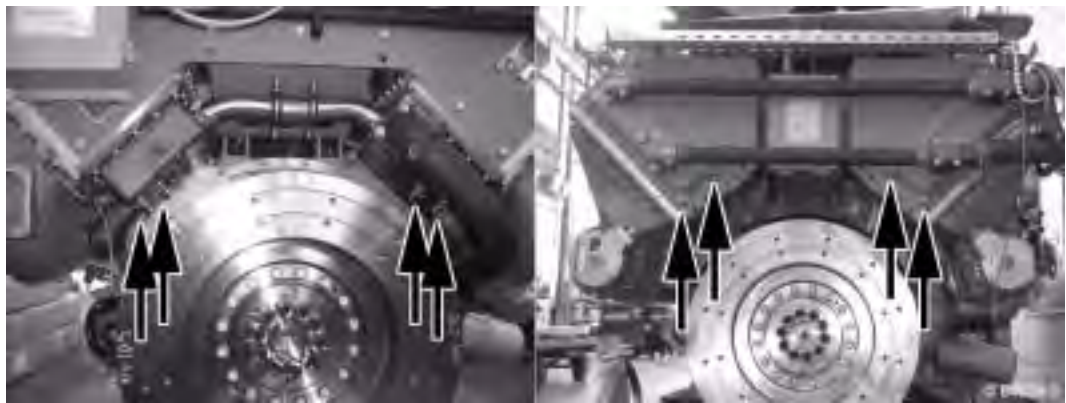

A 2 Beispiel Ablasventile, -stopfen Gemischkühler



A 3 Beispiel Ablasstopfen Ölkühler

- Position the collecting vessel in the appropriate place.
- Shut off water pipes from and to the engine.
- Unscrew screws.
- Drain the coolant.
- After total drainage of the coolant, re-tighten the drain screws.
 - Use new gaskets and sealing rings.

Filling the cooling system



Use the required quality of coolant as described in chapter 4, Operating materials.

Use the right percentage of corrosion protection agent or antifreeze following job card B 9-1-1.

- Fill the engine cooling system with the prepared coolant.
 - The filled cooling system bleeds automatically.
 - When refilling, it is necessary to bleed the coolant pipe at the highest point.
 - Loosen the hollow screws until the coolant emerges without bubbles.
- Open water pipes from and to the engine.
- Check pipes, connections and the engine for leaks after filling and repair if necessary.
- Check the coolant level again, top up if necessary.

Checking percentage of corrosion protection agent or antifreeze in coolant



Tools

- Commercially available tools
- Measuring instrument (from test case order no. 12158292)



Spare parts

- Corrosion protection agent or antifreeze if necessary



References

- Chapter 4, [Operating media](#)

General information

Corrosion protection agent is added to the coolant to protect the coolant areas from corrosion. However, this protection is only given when a certain minimum content of corrosion protection agent is not exceeded. If there is more corrosion protection agent than necessary in the coolant, the cooling effect is reduced.

If an antifreeze is added to the coolant, this should also have corrosion protection properties. A corrosion protection agent does not need to be added in this case. The antifreeze percentage must be dosed accordingly for the above mentioned reasons.

If the cooling system needs refilling, the percentage of antifreeze or corrosion protection agent in the coolant must be measured. Then the coolant should be corrected according to the following description.



Danger of burns !

Corrosion protection is not a fire hazard in the hardened state.

Checking the percentage of corrosion protection agent or antifreeze

- Remove the coolant sample from the cooler, compensation tank or draining tap.
- Check the percentage additive with the measuring instrument, see TR 0199-99-2091.

Correct the corrosion protection agent and antifreeze percentage

- up to low additive percentage:

$$A = B \times (C - D) / 100$$

- A = amount of additionally required additive
- B = Total filling volume
- C = Setpoint
- D = Measured value

- Drain necessary volume of coolant.
- Mix the drained coolant with the volume of additive to be refilled well.
- Fill in mixture.

- up to high additive percentage:

$$A = (1 - B / C) \times D$$

- A = coolant to be drained
- B = Setpoint
- C = Measured value
- D = Total filling volume

- Drain necessary volume of coolant.
- Fill up cooling system with pure water.



Note water quality - see chapter 4, Operating materials

- Bleed the cooling system.

Drain water from and fill air bottle (starter air tank)

TBG 620
B 10-7-1



Tools

- Commercially available tools

- Open drain valve 1 slowly until water emerges. If no water emerges, close the drain valve again.
- Fill up the air bottle to 30 bar every time before switching off the engine.



Do not open the drain cock too far because water is displaced if the flow speed is too great and only air escapes. A rising pipe 2 is installed on vertically erected air bottles. The air pressure in the air bottle presses the water through out through the rising pipe into the open. If no water emerges for several maintenance periods, have the air bottle checked.

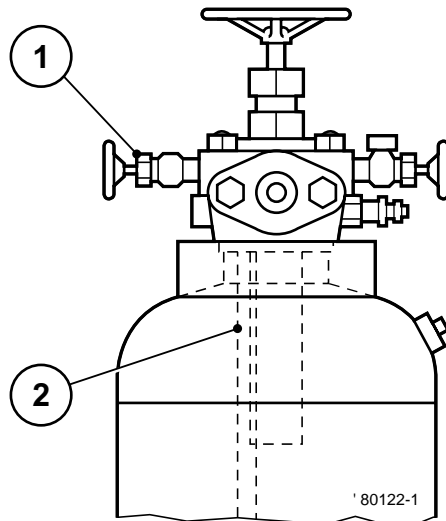

A 1 Starter air bottle

B 10-7-1
TBG 620

Servicing the battery



Tools

- Commercially available tools
- Acid tester (order no. 12157944)



Auxiliary material

- Distilled water
- Acid protection grease
- Cloth

Technical data

Test and setting values

Battery acid density	Charge status	Normal	Tropical
	well charged	1.28 kg/l	1.23 kg/l
	semi-charged (re-charge)	1.20 kg/l	1.12 kg/l
	discharged (recharge, renew if necessary)	1.12 kg/l	1.08 kg/l

General information



Caution, explosion hazard !

The gases emitted by the battery are explosive.
Avoid sparks and naked flames.



Danger of burn !

Do not allow battery acid to come into contact with skin or clothing.
Wear protective glasses and clothing.



Danger of short-circuit !

Do not rest tools on the battery.
Cover the battery poles.



Danger of injury !

Only work with the engine at a standstill.
Secure the engine against starting.



Keep battery clean and dry.

Check battery and cable connectors

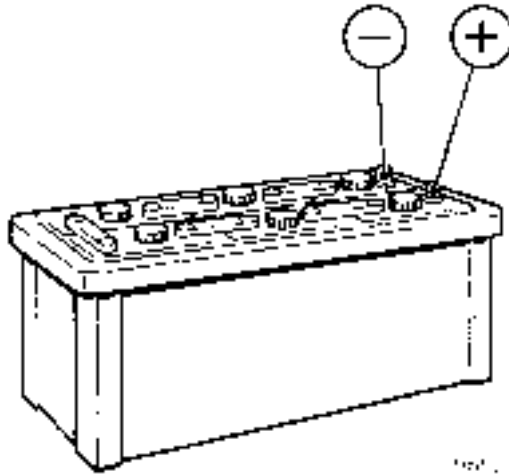

A 1 Battery poles

- Remove dirty clamps.
- Clean the battery poles and clamps.
- Plug on and tighten clamps.
- Grease clamps with acid-proof grease.
- When reassembling, ensure that clamps make good contact. Tighten clamp bolts hand-tight.



Make sure the clamps have good contact.

Check acid level

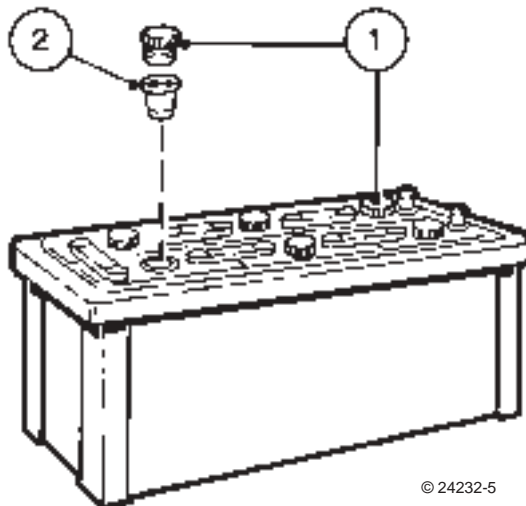

A 2 Battery sealing caps

- Unscrew and remove sealing caps 1.
- Visually check the acid level.
 - without control inserts 2: liquid level 10 - 15 mm above top edge of plate.

- with control inserts 2: liquid level up to their floor.



Only use distilled water for refilling.

Check acid density

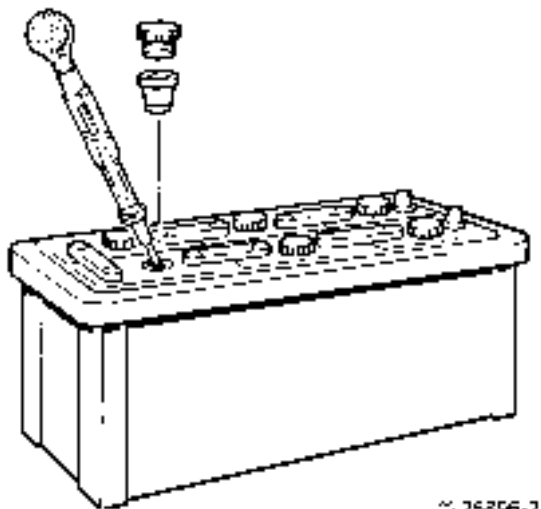

A 3 Check acid density

- Measure the acid density with a commercially available acid tester.



During measurement, temperature should preferably be 20 °C.



If the battery is recharged, all the stoppers must be removed before charging.
Check the acid level after charging and correct if necessary.

Correct the acid density

if acid density too low:

$$A = B \times (C - D) / (E - D)$$

A = Amount of acid to be refilled

B = Cell content

C = Nominal density

D = Acid density in the cell

E = Density of acid to be refilled

- Suck amount of acid to be refilled from the battery.
- Fill determined amount of battery acid into the battery.

if acid density too high:

$$A = B \times (C - D) / (C - 1)$$

A = Amount of water to be refilled

B = Cell content

C = Acid density in the cell

D = Nominal density

- Suck amount of water to be refilled from the battery.
- Fill determined amount of water into the battery.

Removing and installing spark plugs, checking ignition cable



Tools

- Commercially available tools
- Spark-plug wrench
- Feeler gauge 0.25 mm
- Torque wrench



Auxiliary material

- Compressed air
- Safety goggles



Spare parts

- Sealing rings for spark plugs
- Spark plugs if necessary

Technical data

Test and setting values		
Spark plug	Electrode gap	0.25 mm

Tightening specifications		
Spark plug on cylinder head		52 Nm

General information

If there is an electrode gap of more than 0.25 mm when testing, the spark plug may be adjusted. As the earth electrodes may only be bent twice, the correction of the electrode gap should be noted in the operating check log.



Danger of injury !

Only work with the engine at a standstill.

Secure the engine against starting.



Mortal danger !

When working on the high voltage ignition system.

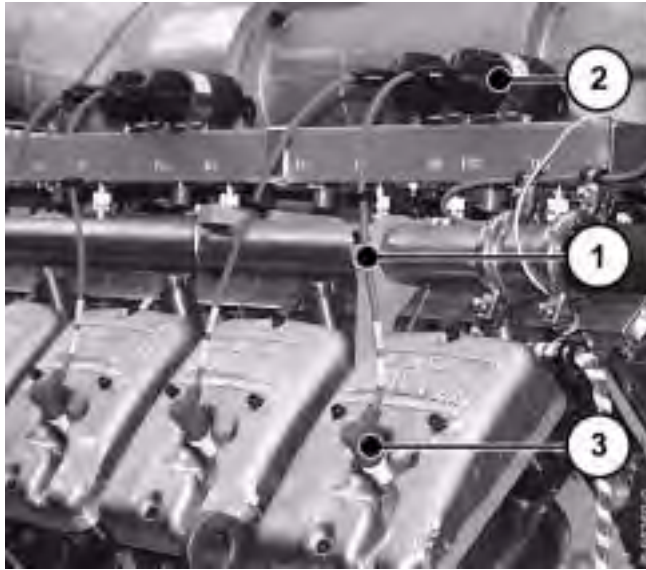

A 1 Ignition coil, cable

Removing the spark plug

- Pull ignition cable 1 from ignition coil 2.
- Pull spark-plug connector 3 off the spark plug.
- Check the spark plug shaft for dirt.



The sealing rings of the spark plug protective pipe must be renewed when oil gets into the spark-plug shaft.

Please contact your service partner if coolant gets into the spark-plug shaft.

- Blow out spark plug shaft with compressed air.



Particles of dirt can cause injury when cleaning with compressed air.

Wear safety glasses and close-fitting clothing.

- Remove spark plug.

Checking and adjusting the spark plug

- Check electrode gap with feeler gauge.
 - Set the electrode gap by slightly bending the earth electrode to the setpoint if necessary.



If the middle electrode is burnt out or soiled, the spark plug must be renewed.

Cleaning the spark plug is not permissible!

Checking the ignition cable

- Visually inspect the ignition cable for damage and renew if necessary.

Installing the spark plug



If the spark plug is renewed, the new spark plug must be checked for damage.

The electrode gap must also be checked and set if necessary.

- Renew the sealing ring of the spark plug.
- Insert and tighten spark plug.
- Plug the ignition cable to the ignition coil.

Service

Sales & Service Index

This Sales & Service Index offers you an overview of the DEUTZ Power Systems branches in your vicinity, including the products for which they are responsible and the range of services provided. Even when no direct product responsibility is mentioned, your local branch will be happy to help you with expert advice. The Index is constantly updated. Please ask your DEUTZ Power Systems service partner for the latest edition.

Order no.: 0312 0807 (CD-ROM)



DEPIC

The **DE**utz **P**arts **I**dentification for **C**ustomers (DEPIC) offers you spare parts identification individually adapted to your systems. DEPIC enables you to generate an order list almost automatically, making ordering your spare parts more efficient. Order no.: on request (CD-ROM)



Tutorial programs

The degree of availability, reliability and service life of equipment and drive assemblies are determined to a great extent by professional operation and service by qualified and experienced operators and service technicians. The DEUTZ AG Power Systems also offers service-related seminars for DEUTZ Power Systems products to the staff of customers and operators. Apart from the standard seminars, held in our Training Centre in Mannheim, it is also possible to arrange special seminars, either in the Training Centre or at another location requested by the customer. Information about the seminar program will be distributed in a circular. Please ask your DEUTZ Power Systems Service representative.

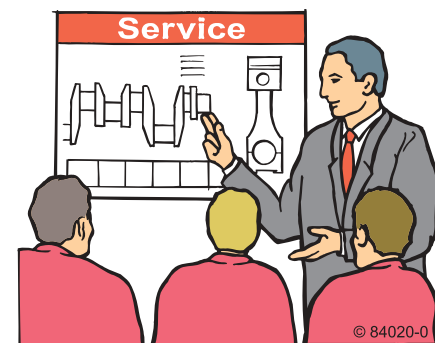

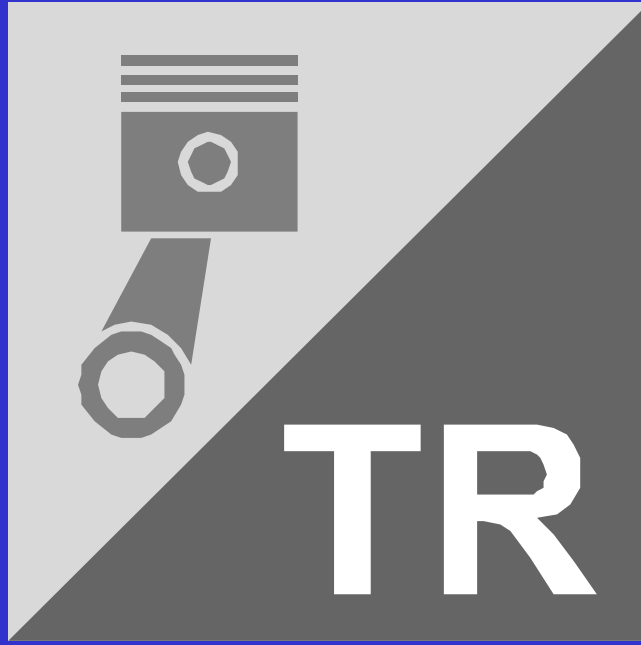





DEUTZ AG
Deutz-Mülheimer Straße 147-149
51063 Köln

Technical Circular

0199 - 99 - 2091 en

5th Exchange

Product:

Medium and large size engines



TR

Date: 07.01.2004

This Circular supersedes: 0199-99-2091 4th Exchange
of 11.05.2001

Copies to: 0080

- **Service- Partners At Home and Abroad**
(subsidiaries, agencies, dealers)
- **Service Centers + Xchange Center Germany**
- **Pocket Book Holders**
- **Company Departments (02)**
- **Original equipment manufacturers (OEM)**
or end customers

Drawn up by: VS-TIM Phone: +49 (0) 221 822 3687
Fax: +49 (0) 221 822 2752

Adress:

Note: The part numbers indicated in this document serve technical explanation purposes.
Exclusively the spare parts documentation is binding for the definition of spare parts.

Engine coolant for DEUTZ medium and large-size engines

This 5th Exchange is issued amongst other things because of a

- Revision of the data on water quality
- Introduction of the DEUTZ protective agent for cooling circuit in 20 litre cans
- Updating of product recommendations , Enclosures 1 and 2.

Contents

- 1 General
- 2 Water quality
- 3 Protective agents for cooling circuit
 - 3.1 Chemical anticorrosion agent
 - 3.2 Antifreeze agents with corrosion inhibitors
 - 3.3 Corrosion inhibitors
- 4 Details on cooling circuit
 - 4.1 Monitoring of cooling circuit
 - 4.2 Cleaning of cooling circuit
 - 4.3 Coolant disposal

Enclosures 1 and 2: Product recommendations for cooling circuit protective agents

Enclosure 3: Disposal of DEUTZ cooling systems protective agent (only in German issue)

1 General

Coolants of liquid-cooled engines must be treated and monitored since damage may be sustained by engine otherwise due to

- corrosion
- cavitation
- freezing

2 Water quality

The correct water quality is important for the preparation of the coolant. If no specifications are provided by the manufacturer/supplier, clear and clean water must be used within the following limit values of analysis:

Limit values of analysis		min.	max.
pH value at 20°C		6,5	8,5
Chloride ion content	mg/dm ³	-	100
Sulphate ion content	mg/dm ³	-	100
Total hardness * ¹	°dGH	3	12

*¹ Share of carbonate hardness in the overall hardness min. 3°dGH.

For more information on the water quality please consult your local waterworks or use the DEUTZ test kit, Order No. 12130382.

Water treatment is indicated if water qualities differ from the above indicated limit values of analysis.

- **pH value too low**
Add diluted caustic soda or potash lye and mix.
Preparation of small sample mixtures is recommended.
- **Total water hardness too high:**
Mix with softened water *²
- **Total hardness and/or carbonate hardness too low**
Mix with water of a higher hardness *³
- **Chloride and/or sulphate content too high**
Mix with softened water *²

*² Softened water is distilled water, pH-neutral condensate or water treated by ion exchangers.

*³ Water of a higher hardness is available in most cases in form of potable water (town water).

Use the DEUTZ test kit (order No. 12130382) for a determination, if the limit values of analysis of the water to be admixed are unknown.

For safety reasons it is mandatory to carry out another water analysis after water treatment.



Sea water, river water, brackish water or industrial waste water are in no case suitable for the preparation of the coolant since damage may be sustained by the engine.

3 Protective agent for cooling circuit

The coolant is prepared by adding a protective agent to the cooling water as a protection of the cooling circuit. The following additives are commonly used:

- Chemical anticorrosion agent
- Antifreeze agent with corrosion inhibitors
- Corrosion inhibiting oil

The type of additive can be selected according to the following table:

	Chemical anticorrosion agent	Antifreeze agent with corrosion inhibitors	Corrosion inhibiting oil
Protection against corrosion	good	good	good
Protection against cavitation	satisfactory	satisfactory	good
Protection against freezing	none	up to -45°C according to mixing ratio	none
Maintenance requirement	low	low * ⁴	very high
Operating reliability	good	good	insufficient
Costs	medium	very high	medium

*⁴ Only the antifreeze effect is checked normally, to be exchanged every 2 years.

Enclosure 1 lists up some representative products which are recommended by us and which as indicated by the manufacturers/suppliers are suitable for the processing of coolants. Also other equivalent products of other manufacturer/suppliers may be used as an alternative. Suitability of the protective agent for the cooling circuit must be warranted/guaranteed by the manufacturer/supplier. No liability is accepted by us.

The various protective agents for the cooling circuit are described below.

3.1 Chemical anticorrosion agent

Chemical anticorrosion agents are compounds which by way of chemical reaction form a protective film on the metal surfaces. Their advantage compared to corrosion inhibiting oils lies in the ease of application and monitoring.

Liquid additives may be admixed directly in the engine, additives in powder form are to be pre-mixed. The manufacturer's instructions must be adhered to with regard to the concentration of the chemical anticorrosion agent and subsequent monitoring.

The manufacturer/supplier shall warrant that his additives do not have a detrimental effect on the materials used in the engine (e.g. seals/gaskets).

Be careful with aluminium components in the cooling circuit. Not all chemical anticorrosion agents are suitable in such cases; correct dosing is of particular importance since too low a concentration of the chemical anticorrosion agent will have a damaging effect on the system. Also considered in the list of recommended products (see Enclosure 1) is the suitability of the anticorrosion agent for engines with aluminium components.

Make sure that aluminium components are properly grounded, no additional electric currents may be induced by these aluminium components via defective insulations (single pole sensors and monitoring sensors).

Chemical anticorrosion agents containing silicates may have a negative effect on the service life of the axial-face seals. Such products should only be used for engines which separately mounted coolant pumps equipped with seals which are resistant to these chemical anticorrosion agents.

Filter systems are available as an alternative, capable of filtering out solid particles from the cooling circuit in addition to providing a protection against corrosion. These filters contain a chemical anticorrosion agent in solid form which is gradually dissolved in the cooling water.

Chemical anticorrosion agents and antifreezes as per Section 3.2 are compatible.

 Not all chemical anticorrosion agents and antifreeze agents are compatible. Carcinogenic nitrosamines will form when mixing amine based chemical anticorrosion agents with nitrate based antifreeze agents. For compatibility please consult the manufacturer/supplier.

Most of the recommended chemical anticorrosion agents may be mixed with the antifreeze agent from DEUTZ (an antifreeze based on ethylene glycol) without incurring any risk.

3.2 Antifreeze agents with corrosion inhibitors

Antifreeze agents are generally used for DEUTZ engines only if ambient temperatures below zero are likely to occur. The antifreeze agent may be added to the chemical anticorrosion agent (manufacturer/supplier to be contacted for compatibility) or may be added to the water as the only protective agent against freezing and corrosion. Antifreeze agents based on ethylene glycol are used in general. The anticorrosive substances contained in the antifreeze are agents which prevent corrosion by forming a protective film on the surface of the components.

Provide for the following concentrations:

Antifreeze agent	10%	15%	20%	25%	30%	35%	40%	45%	50%
Water	90%	85%	80%	75%	70%	65%	60%	55%	50%
Antifreeze effective up to	-4°C	-7°C	-10°C	-13°C	-18°C	-22°C	-28°C	-35°C	-45°C

When the antifreeze agent is used as the only anticorrosion agent (without any chemical anticorrosion agent) it must be left in the coolant both during winter and summer time; minimum concentration 35%.

 Use of antifreeze reduces the heat transfer coefficient (thermal capacity) of the coolant. Check whether the cooling circuit is laid out accordingly.

Admixture of a corrosion inhibiting oil emulsion is not permissible.

Best results are obtained with the **DEUTZ protective agent for cooling circuits** as an antifreeze with anticorrosion inhibitors. This ethylene glycol based protective agent for cooling circuits is matched to the materials used on DEUTZ medium and large size engines and is subject to permanent control and monitoring. This agent is obtainable from the DEUTZ organisation and is supplied in form of

5 litre containers	Part No. 0101 1490
20 litre containers	Part No. 0101 6416
210 litre barrel	Part No. 1221 1500

If the DEUTZ protective agent for the cooling circuit should not be available for important reasons such as supply restrictions abroad, other products may be used in exceptional cases. Such alternative products have been grouped together in product groups and are listed up in Annex 1. Products of the same product group may be mixed. Products of different product groups may not be mixed. The entire cooling circuit must be cleaned thoroughly before a product change.

3.3 Corrosion inhibiting oil

Use of corrosion inhibiting oils is a problem because of the poor stability of the emulsion, the resulting difficulties in monitoring and the potential damage involved.

Corrosion inhibiting oils are emulsive mineral oils with additives which form a thin protective film on the components of the cooling circuit preventing corrosion and furring.

The emulsion must be prepared in a container outside the engine cooling water circuit adding the specified amount of corrosion inhibiting oil to the water stirring the mixture thoroughly. Concentration as specified by the manufacturer/supplier.

Loss of coolant to be made up for, excessively low concentrations of corrosion inhibiting oil to be compensated by adding a highly concentrated emulsion.

Corrosion inhibiting oils must not be used for:

- cooling circuits with connection to a comfort heating system
- gas engines

4 Details of the cooling circuit

4.1 Regular checking of the cooling circuit

The cooling circuit must be checked regularly (see current Operating Instructions) which includes checking for contamination and checking of the coolant level as well as the concentration of the protective agents of the cooling circuit.

- Chemical anticorrosion agent:
Check concentration; suitable tools for testing such as test rods are supplied by the manufacturers/suppliers.
- Antifreeze agent with corrosion inhibitors
Check antifreeze and anticorrosion effects with antifreeze tester.
- Corrosion inhibiting oil
Check concentration of corrosion inhibiting oil with refractometer, check condition of emulsion.

Renew coolant always in case of:

- ingress of raw water
- Ingress of lube oil
- pronounced turbidity due to corrosion residues or other suspended matter
- a spent corrosion inhibiting emulsion
- the antifreeze agent to be renewed every 2 years.

4.2 Cleaning of cooling circuit

The cooling circuit must be cleaned if contaminated, corrosion inhibiting oil emulsion is spent or in the case of lube oil or raw water ingress. The entire coolant must be drained in such as case and the cooling circuit must be flushed using a suitable detergent. The cooling circuit must also be cleaned when changing over to another type of protective agent for the cooling circuit.

Suitable detergents are offered on the market, suitability must be guaranteed by the manufacturer/supplier, however.

4.3 Coolant disposal

The coolant must not be drained into the sewage system. Disposal to be taken care of by a company specialised in waste disposal in accordance with the national legal requirements and the instructions of the manufacturer/supplier.

 For disposal of the DEUTZ protective agent for the cooling circuit within the Federal Republic of Germany please refer to Annex 3 (published in German only).

DEUTZ AG
Service Information Systems

i.V. Sonntag
- Sonntag -

A. Asselborn
- Asselborn -

Annexes



Recommended Products
Protective agents for cooling circuit

Annex 1 to
TR 0199 - 99 - 2091
5th Exchange
01/2004

Antifreeze Agents with Corrosion Inhibitors

Product Group A: for medium and large size engines

Product Group B: for medium size engines

Product Group	Manufacturer/ Supplier	Product Name	Notes/ available in
A	DEUTZ AG	Cooling system protective agent PN 0101 1490 PN 0101 6416 PN 1221 1500	5 litre container 20 litre container 210 litre barrel
	ARAL	Antifreeze Extra	
	AVIA	Antifreeze APN	
	BASF	Glystantin G48/Protect Plus	
	BUCHER (Schweiz)	Motorex Antifreeze Protect Plus G48	
	INA Industrija	INA Antifriz AL Super	
	The Burma OIL	Castrol Antifreeze NF	
	FUCHS EUROPE	FUCHS FRICOFIN	
	TOTAL	ELF Glacelf MDX	
	OMV	OMV coolant plus	
	Shell	GlycoShell	
	VALVOLINE	G48 Antifreeze	
	Veedol	Veedol Antifreeze NF	
	BP	BP antifrost Code No. X 2270 A	
	Hunold	Kühlerschutz ANF	
INEOS	Napgel C2270/1		
Mobil	Frostschutz 600		
B	AGIP	Antifreeze special	
	ARTECO/Texaco	Havoline XLC	Europe, south-America
	CALTEX	Havoline XLC	Asia, Australia
	ChevronTexaco	Chevron Extended Life Coolant	
	Orvema b.v.	Orvema Protex LL	Netherlands
	TOTAL	ELF Glacelf Auto Supra Total Organifreeze	
	Texaco USA	Havoline Extended Life Coolant (HELAC) Extended Life Coolant (TELC)	USA, w/o Nitrit and Molybdenum USA, with Nitrit



Recommended Products Protective agents for cooling circuit

Annex 2 to
TR 0199 - 99 - 2091
5th Exchange
01/2004

Chemical Anticorrosion Agents

Manufacturer/ supplier	Product name	Diesel engines 234, 616, 2016, 604, 620, 2020	Gas engines 234, 616, 604, 620, 2020 632, 2032	Diesel engines 628, 640, 645	Notes
BEDIA	Bedia Liquid BL1 * Bedia BS/BT mit BP1 * Bedia BL2	- - X	X X X	X X X	Filter systems
DREW AMEROID	DEWT-NC Liquidewt Maxiguard	- - -	- - -	X X X	Powder
Fuchs	FUCHS ANTICORIT S 2000 A	X	X	X	
Houseman Limited	Cooltreat 651 *	-	X	X	
NALFLEET	9-108 9-111 * 9-131 C	- - -	- X -	X X X	
REICON	ODACON Z	X	X	X	
Perry (W. Lösing)	Liquid Perry * Perry Filter *	- -	X X	X X	Filter systems
Texaco	Havoline XLI	X	X	X	
Total	Total WT Supra	X	X	X	
UNITOR ASA	Dieselguard NB Pulver ROCOR NB Liquid	- -	- -	X X	not to be mixed with antifreeze agent
Vecom	CWT Diesel / QC 2	-	-	X	

* Product contains silicates

Corrosion inhibiting oils – not for gas engines –

Manufacturer/ supplier	Product name	Diesel engines 234, 616, 2016, 604, 620, 2020 628, 640, 645	Notes
DEUTSCHE Castrol	CASTROL PRODUCT 481/43	X	
Deutsche Shell AG	Shell 9156	X	
ESSO AG	Kutwell 40	X	
Mobil	Coolant Inhibitor	X	



DEUTZ AG
Deutz-Mülheimer Straße 147-149
51063 Köln

Technical Circular

0199 - 99 - 2105 en

5th Exchange

Product:
DEUTZ Gas Engines



Date: 27.10.2003

This Circular supersedes: 0199-99-2105/4 of 11.05.2001

Copies to 0131

Adress:

- **Service- Partners At Home and Abroad**
(subsidiaries, agencies, dealers)
- **Service-Centers + Xchange Center Germany**
- **Pocket Book Holders**
- **Company Departments (02)**
- **Original equipment manufacturers (OEM)
or end customers**

Drawn up by: VS-TIM Phone: +49 (0) 221 822 3687
Fax: +49 (0) 221 822 2752

Note: The part numbers indicated in this document serve technical explanation purposes.
Exclusively the spare parts documentation is binding for the definition of spare parts.

DEUTZ gas engines – Lube oil

This 5th Exchange Circular is issued essentially for

- providing more precise data on lube oils for special gases
- revising the limit values of the lube oil analysis
- updating the lube oil table.

The technical advancement of DEUTZ gas engines featuring high efficiencies and low exhaust emissions requires special, particularly adapted lube oils with a low ash content. **DEUTZ OIL TG-40 LA** is recommended by us for use in DEUTZ gas engines. This oil is adapted to the needs of gas engines and gas given excellent in-service results in heavy-duty engines operation. If this oil is not available, lube oils listed in enclosure 1 can be used as an alternative. For gas engines operating on special gases (e.g. dumping grounds, sewage plants) which are exposed to higher contamination (limits referred to 100% CH₄)

Chlorine (Cl)	>	30 mg/m ³
Fluorine (F)	>	15 mg/m ³
Total chlorine + fluorine (Cl + F)	>	30 mg/m ³
Sulphur (S)	>	300 mg/m ³

special lube oils according to enclosure 2 are recommended, in spite of the higher sulphate ash content, if the specified limit values are exceeded or the anticipated lube oil service life is not attained due to the influence of attendant fuel gas substances.

Lube oil service life

The lube oil service life is dependent on:

- Gas quality
- Lube oil grade
- Ambient conditions
- Engine mode of operation

It is therefore necessary to determine for each engine plant the lube oil change intervals by analysis of the used oil.

For bio gas, the 1st analysis should be carried out after 100 running hours and for the other types of gas after 300 running hours. Further intervals to be observed for analysis and lube oil change should be agreed between the operator and the laboratory on the basis of the following limit values.

Limit values for lube oil analysis		Remarks Measuring method				
Viscosity at 100°C	min. 12 mm ² /sec (cSt)	DIN 51 366, ASTM D 445 DIN EN ISO 3104				
	max. increase 3 mm ² /sec max. 18 mm ² /sec	DIN 51 366				
Water content	max. 0,2%	DIN51777 ASTM D 1744				
Glycol content	max. 500 ppm	DIN51375 ASTM D 4291				
Total base number TBN	> 40% of new oil min. 2,0 mgKOH/g	ISO 3771				
AN	≤ of simultaneous TBN	ASTM 664				
SAN	0 mgKOH/g	ASTM 664				
i pH *	≥ 4,5	DEUTZ				
Oxide 5,8 µm	20 A/cm	DIN 51 451				
Nitr. 6,1 µm	20 A/cm	DIN 51 451				
Wearing metals:	Engine				DIN51391 ASTM D 5185	
		1015 2015	616 2016	620 2020 (604B/C)	632 2032	
Aluminium	max. mg/kg	20	10	10	5	If two or more wearing metals exceed the limits of 10 mg/kg, the subsequent time interval for sampling must be cut in half. If higher values of wear are confirmed, please consult DEUTZ customer service.
Chromium	max. mg/kg	10	5	5	5	
Copper	max. mg/kg	20	25	15	10	
Iron	max. mg/kg	30	30	20	20	
Lead	max. mg/kg	20	20	20	10	
Tin	max. mg/kg	10	10	5	5	
Silicium	max. mg/kg out of dust **	15	15	15	15	DIN51391 ASTM D 5185

* Biogas

** In the case of engines running on sewage and landfill gas the contamination can also be caused by siloxanes. The elements exposed to wear must be carefully observed.
The Si limit value is reached if the proportion of wearing metals increases to max. 300 mg/kg.

Not only the limit values but also the course of the recordings of a number of analyses of the oil should be considered in the assessment of the wear components to be sure to detect variations of the engine condition earliest possible.

You are advised to document the analysis of the oil and produce this evidence for reference, if necessary. In the case of abnormal wear within a series of analyses, you are obliged to make available the documented analysis to DEUTZ Product Engineering if engines under warranty are involved.

Following a series of three analyses, the analysis can be limited to the oil sample taken during lube oil change, provided the operating conditions remain the same.

Explanatory notes to the limit values of the lube oil analysis

Abbreviation	Term	Explanation
TBN (mgKOH/g)	Total Base Number	Total base number, identifying the alkaline reserve of the oil and characterising the chemical capacity of neutralization
AN	Total Acid Number	covers weak and strong acids
SAN	Strong Acid Number	covers strong acids only, e.g. sulphuric acid
ipH	Initial pH-Value	Initial pH value
Oxid. 5,8 µm	Oxidation	covering carbonyl compounds in the IR spectrum (infrared) of 5.8 µm
Nitr. 6,1 µm	Nitration	Nitrification by ground bacteria, measured in the IR spectrum (infrared) of 6.1 µm
A/cm		Absorption per cm of wavelength in the spectrogram
KOH	Potassium hydroxide	

Lube oil change

Lube oil to be changed **after**

- Analysis
- Coolant ingress into lube oil
- Servicing work on maintenance level E 60 (see Operation Manual)
- Repair work exceeding the scope of maintenance level E 50 (see Operation Manual)
- at least once a year if engine is run less than 2,000 running hours annually.

New intervals for lube oil change must be fixed in case the mode of operation is changed, following service work E60 and/or repair work equivalent to E60.

The lube oil sample is to be taken

- with the engine running by means of the quick coupler directly from the lube oil circuit or
- directly after the engine has come to a standstill from the oil pan.

Fill the cubic centimetres taken as the initial sample back into the engine. Then fill into a clean test bottle.

Lube oil filter change

Lube oil filter cartridges to be changed

- together with the first lube oil change
- thereafter every 1,500 to 3,000 operating hours (see maintenance chart in Operation Manual)
- minimum once a year.

If water is analysed in the lube oil or a SAN is measured in the lube oil or servicing work acc. to maintenance level E 60 and/or repair work corresponding to E60 in terms of scope has been carried out, also filter cartridges must be changed in the course of the next lube oil change.

DEUTZAG
Service Information Systems

i.V. Sonntag
- Sonntag -

A. Asselborn
Asselborn -

Encl. Lube Oil Tables



Lube Oil Table DEUTZ Gas Engines

Enclosure 1 to
TR 0199-99-2105
5th Exchange
10 / 2003

Lube oils for gas engines operating with all types of low contaminated gases

Manufacturer	Type of lube oil	Viscosity-class SAE	Base oil	Sulphate ash weight per cent	Total base number (TBN) mgKOH/g	Viscosity	
						at 40°C	at 100°C
DEUTZ	DEUTZ ÖI TG-40 LA	40	Mineral	0,43	5,7	156,0	14,5
ARAL AG	Degasol LA	40	Mineral	0,48	4,5	137,0	13,7
BP AG	Energol IC-DG 40S	40	Mineral	0,48	4,5	137,0	13,7
CEPSA	Troncoil Gas	40	Mineral	0,35	4,6	133,8	13,8
Exxon Mobil	Pegasus HPC	40	Mineral	0,48	5,5	138,0	14,1
	Pegasus 1	15W-40	Synthetic	0,48	7,0	132,0	13,6
	Pegasus 605	40	Mineral	0,50	7,4	119,0	13,0
	Pegasus 705	40	Mineral	0,49	5,3	122,0	13,1
	Pegasus 805	40	Mineral	0,50	6,2	130,0	13,5
	Pegasus 905	40	Mineral	0,50	6,2	115,0	12,7
FUCHS Europe	Fuchs Titan GM LA	40	Mineral	0,43	5,7	156,0	14,5
Kuwait Petroleum	Q 8 Mahler MA	40	Mineral	0,50	5,5	141,2	13,9
Petro-Canada	Sentinel 445	40	Hydro. Tr	0,40	4,7	127,0	13,2
Repsol	Extra Gas 40	40	Mineral	0,40	6,0	130,0	13,5
Roloil	Mogas / 40	40	Mineral	0,50	5,5	141,2	13,9
Shell	Mysella LA	40	Mineral	0,45	5,0	138,0	13,8
	Mysella XL	40	Mineral	0,50	4,5	131,0	14,1
TOTAL FINA ELF	ELF Nateria MHW 40	40	Mineral	0,35	4,6	133,8	13,8
	ELF Nateria MH 40	40	Mineral	0,45	5,2	139,0	13,9
	FINA Gasmotorenöl 505	40	Mineral	0,48	5,5	155,0	15,1
TEXACO	GEOTEX LA	40	Mineral	0,45	5,5	129,4	13,3
	GEOTEX PX	40	Mol. conv	0,50	5,4	88,0	13,2
WIPA Chemicals International	Ecosyn GE 4004	40	Ester	0,40	6,0	155,0	13,7



Lube Oil Table DEUTZ Gas Engines

Enclosure 2 to
TR 0199-99-2105
5th Exchange
10 / 2003

Lube oils for gas engines operating with higher contaminated special gases

Manufacturer	Type of lube oil	Viscosity class SAE	Base oil	Sulphate ash weight per cent	Total base number (TBN) mgKOH/g	Viscosity	
						at 40 °C	at 100 °C
Caltex	Geostar LF 40	40	Mineral	0,99	8,0	138,0	14,0
Kuwait Petroleum	Q8 Mahler HA	40	Mineral	0,90	7,9	141,2	14,1
Mobil	Pegasus 610	40	Mineral	0,96	9,5	131,0	13,5
Roloil	Mogas 40 AC	40	Mineral	0,90	7,9	141,2	14,1
Texaco	Geotex LF 40	40	Mineral	0,99	8,0	138,0	14,0



DEUTZ AG
Deutz-Mülheimer Straße 147-149
51063 Köln

Technical Circular

0199 - 99 - 2116 en

1st Exchange

Product:

DEUTZ medium and large engines (Diesel and Gas)

Date: 13.12.2004

This Circular supersedes:
TR0199-99-2116 of 10.01.2000



TR

Copies to: 0080

- Service- Partners At Home and Abroad (subsidiaries, agencies, dealers)
- Service Center + Xchange Center Germany
- Pocket Book Holders
- Company Departments (02)
- Original equipment manufacturers (OEM) or end customers

Drawn up by: VS-TIM Phone: +49 (0) 221 822 3687
Fax: +49 (0) 221 822 2752

Adress:

Note: The part numbers indicated in this document serve technical explanation purposes.
Exclusively the spare parts documentation is binding for the definition of spare parts.

Engine corrosion protection

Ž

This Technical Circular applies for all DEUTZ medium and large engines and for the DEUTZ gas engine TCG2015

- 1 General
- 2 Corrosion protection for engines which have been in operation
 - 2.1 Interior corrosion protection
 - 2.2 Exterior corrosion protection
 - 2.3 Storage and packaging
- 3 Subsequent corrosion protection of engines
 - 3.1 Interior corrosion protection
 - 3.2 Exterior corrosion protection
 - 3.3 Storage and packaging
- 4 Removal of corrosion protection
 - 4.1 Removal of interior corrosion protection
 - 4.2 Removal of exterior corrosion protection
- 5 Corrosion protection agents / cleaning agents

1 General

New engines and replacement parts are protected against corrosion before being shipped from the plant. The duration of protection against corrosion depends on the type of corrosion protection, the packaging and the storage conditions at the place of installation. Corrosion protection may be guaranteed for 12 months or 24 months depending on what the customer wants.

In engines a distinction is made between

- interior corrosion protection and
- exterior corrosion protection

All engines have both kinds of corrosion protection.

The following corrosion protection measures **after taking the engine out of operation or subsequent corrosion protection** of engines which have not yet been installed meet the requirements for 12 months full protection.

At the end of the corrosion protection work the crank drive may no longer be turned so that the corrosion protection agent in the bearings, bearing liners and cylinder liners is not scraped off.

2 Corrosion protection for engines which have been in operation

2.1 Interior corrosion protection

Interior corrosion protection is always provided by wetting of the walls with the implemented corrosion protection agent (see section 5) in a corrosion protection running of the engine.

Fuel system

This includes the injection valves, fuel filter, fuel pump, overflow valve, fuel lines and tank.

Engines operated with a mixed fuel must be switched over to distilled fuel at least 3 hours before shutting down.

- Fill the fuel tank with a mixture of
 - 85% distilled fuel
 - 15% corrosion protection oil SAE 30W-30
- Perform a corrosion protection run with the engine in no-load (together with corrosion protection run for the lube oil system), duration approx. 10 minutes

Lube oil system

This includes oil tray, lube oil pump, lube oil cooler, oil pressure control valve, oil filter, main oil channels, crankshaft, con-rod and camshaft bearings, tappets and tappet chambers, cylinder liners, valve springs and toggle levers.

- Drain lube oil from warm engine.
- Thoroughly clean engine compartment, oil tray, cylinder head with toggle levers, valves, valve springs with distilled fuel or cleaning agent.
- Fill the engine with corrosion protection oil SAE 30W-30 and perform a corrosion protection run (together with corrosion protection run for fuel system, duration approx. 10 minutes) so that all bearings and bearing liners are wetted,
or
wet all components with corrosion protection oil and pump corrosion protection oil through the engine with a separate pump until all bearings and bearing liners are wetted.

In additional devices with their own oil filling (these include turbochargers, governors, injection pumps etc.) drain lube oil and fill with new lube oil according to manufacturer specifications.

Coolant system

If a coolant with corrosion protection properties is poured into the engine, no further action is necessary after draining the coolant.

If this is not the case, the coolant must be drained and a corrosion protection run performed with a mixture of corrosion protection agent with corrosion protection properties (see section 5) and fresh water so that a coating forms on the interior surfaces of the cooling system.

The duration of the corrosion protection run and the concentration of the corrosion protection agent are specified by the manufacturer of the corrosion protection agent.

Then drain the coolant.

Combustion chamber

The injection valves and spark plugs must be removed at the end of the corrosion protection run. The respective piston must be set to LT.

The accessible part of the cylinder liner should be coated with corrosion protection oil with a spray lance through the opening.

Ž Oil drips on the piston are not permissible and must be sucked off if necessary.

Receiver pipe and starter air line

Spray corrosion protection oil 30 W-30 into the receiver pipe and the main starter line.

Ž Oil drips in lines are not permissible and must be sucked off if necessary.

2.2 Exterior corrosion protection

The engine must be cleaned thoroughly with a cleaning agent before exterior corrosion protection. Any signs of corrosion and damage to the paintwork must be removed. See section 5 for corrosion protection agents and cleaning agents.

Bare exterior surfaces and parts

All bare surfaces must be coated or sprayed with a corrosion protection agent.

Brush the crankshaft flange with corrosion protection agent and wrap tightly or cover with foil or packing cloth.

Control rods and joints

Coat control rods and joints with protective grease.

Rubber parts

Rub rubber parts with talcum powder.

Ž Rubber parts must not come into contact with oil, grease and paint.

Engine openings

All engine openings must be fitted with air-tight, water-tight covers to delay the liquefaction process of the corrosion protection agents.

Air should be locked out to avoid ventilation of the engine (chimney effect).

2.3 Storage and packaging

After being protected against corrosion, the engine must be stored in a dry, ventilated hall or suitably covered. The cover must be placed loosely over the engine so that the air can circulate around it to prevent condensation from forming. Use a desiccant if necessary.

3 Subsequent corrosion protection of engines

If the maximum duration of corrosion protection has been reached and the engine is to stay in storage, it must be subjected to subsequent corrosion protection. The subsequent corrosion protection protects the engine for another 12 months. Subsequent corrosion protection must be provided accordingly for stored replacement parts.

Mark the position of the flywheel or crankshaft flange. Deposits may form on the cylinder liner in the area of the piston rings. For this reason, the pistons must be set to a different position each time corrosion protection is carried out.

The engine packaging and the covers over the engine openings must be removed.

3.1 Interior corrosion protection

Fuel system

This includes the injection valves, fuel filter, fuel pump, overflow valve, fuel lines and tank.

- Fill the fuel tank with a mixture of
 - 85% diesel fuel
 - 15% corrosion protection oil SAE 30W-30
- Pump fuel with a separate pump or fuel hand pump until the fuel system is full.

Lube oil system

This includes oil tray, lube oil pump, lube oil cooler, oil pressure control valve, oil filter, main oil channels, crankshaft, con-rod, camshaft bearings, tappets and tappet chambers, cylinder liners, valve springs and toggle levers.

- Clean the engine compartment and oil tray with diesel fuel if necessary.
- Spray cleaned compartments with corrosion protection oil SAE 30W-30.
- Pump corrosion protection oil into the lube oil circuit with separate pump or pre-lubrication hand pump. Turn the engine manually or with electric turning gear so that all bearings and bearing liners are coated. The engine can also be turned with the starter without starting.
- Remove the cylinder head cover and spray valves, valve springs and toggle levers with corrosion protection oil SAE 30W-30.

In additional devices with their own oil filling (these include turbochargers, governors, injection pumps etc.) drain lube oil and fill with new lube oil according to manufacturer specifications.

Coolant system

Fill up the coolant system with a mixture of corrosion protection agent with corrosion protection properties (see section 5) and fresh water and circulate with an external pump so that a new coating forms on the interior surfaces of the cooling system.

The duration of the corrosion protection run and the concentration of the corrosion protection agent are specified by the manufacturer of the corrosion protection agent.

Then drain the coolant.

Combustion chamber

Remove the cylinder head cover and dismantle the injection valves and spark plugs. The pistons must be set to LT.

The accessible part of the cylinder liner should be coated with corrosion protection oil with a spray lance through the opening.

Ž Oil drips on the piston are not permissible and must be sucked off if necessary.

Then turn the engine until the piston is in the UT position and spray the cylinder liner with corrosion protection oil from below.

Suction intake and starter air system, receiver pipe

Spray corrosion protection oil 30 W-30 into the receiver pipe and the main starter line.

Ž Oil drips in lines are not permissible and must be sucked off if necessary.

3.2 Exterior corrosion protection

The engine must be cleaned thoroughly with a cleaning agent before new corrosion protection. Any signs of corrosion and damage to the paintwork must be removed.

Bare exterior surfaces and parts

All bare surfaces must be coated or sprayed with a corrosion protection agent.

Coat the crankshaft flange with corrosion protection agent and wrap tightly or cover with foil or packing cloth.

Control rods and joints

Coat control rods and joints with protective grease.

Rubber parts

Rub rubber parts with talcum powder.

Ž Rubber parts must not come into contact with oil, grease and paint.

Engine openings

All engine openings must be fitted with air-tight, water-tight covers to delay the liquefaction process.

Air should be locked out again to avoid ventilation of the engine (chimney effect).

3.3 Storage and packaging

After being subsequently protected against corrosion, the engine must be stored again in a dry, ventilated hall or suitably covered. The cover must be placed loosely over the engine so that the air can circulate around it to prevent condensation from forming. Use a desiccant if necessary.

4 Removal of corrosion protection

The corrosion protection must be removed from the engine before starting. The packaging must be removed as well as all covers from the sealed openings. Any signs of corrosion and damage to paintwork must be removed. See section 5 for cleaning agents.

4.1 Removal of interior corrosion protection

Fuel system

- If there is a mixture of diesel fuel/corrosion protection oil in the fuel tank, drain it.
- Fill the fuel tank and fuel system with the proper fuel.

Lube oil system

- If there is corrosion protection oil in the oil tray, drain it or pump it out.
- Fill the engine with the lube oil intended for operation. A purge is not necessary.
- In additional devices with their own oil filling (these include turbochargers, governors, injection pumps etc.) drain lube oil and fill with new lube oil according to manufacturer specifications.

Coolant system

- If the implemented corrosion protection agent is compatible with the coolant to be used, this can be filled directly into the coolant system as specified.
- If it is uncertain whether the implemented corrosion protection agent is compatible with the coolant, the cooling system should be purged with fresh water for about 15 minutes before filling.

4.2 Removal of exterior corrosion protection

- Wash all surfaces and components coated with corrosion protection agent with distilled fuel or a suitable cleaning agent.
- Wash out grooves of V-belts if necessary.

5 Corrosion protection agents / cleaning agents

Below we list some reference products for the corrosion protection agents or cleaning agents with which the best results have been achieved. Equivalent products can be used whereby the supplier must guarantee the suitability of the product for the application.

Name	Purpose	Product name Supplier
Distilled fuel	- Cleaning of engine parts - Filling the fuel system 85% distilled fuel	Diesel acc. to DIN EN 590
Corrosion protection oil	- Protect lube oil system - Protect additional devices with own oil filling - 15% to distilled fuel for protecting fuel system	Corrosion protection oil SAE30W-30 BP-ME10 BP-Deutschland Hamburg
Corrosion protection agent	- Protect coolant system	Puriton 3956 Kühler Chemie GmbH 58566 Kierspe or ODACONZ Reicon Chemie 04103 Leipzig
Corrosion protection agent wax-like	- Protect bare exterior surfaces and parts	Gelserol Super Deutsche Castrol 76829 Landau
Protective grease	- for control rods and joints	Renolit MP2 Fuchs Europe GmbH 68169 Mannheim
Talcum	- for rubber parts	Talcum fine, white Silbermann GmbH & Co. KG 86456 Gablingen
Cleaning agent	- to remove corrosion protection agent protection agent	Eskapon S 255 Haug-Chemie GmbH 74889 Sinsheim
Cleaning agent/ thinner	- Thin and remove corrosion protection agent wax-like	Renopal B 150 Fuchs Europe GmbH 68169 Mannheim

DEUTZAG
Service Information Systems

i.V. Sonntag
-Sonntag-

i.A. Asselborn
-Asselborn-

This page intentionally left blank.



DEUTZ AG
Deutz-Mülheimer Straße 147-149
51063 Köln

Technical Circular

0199 - 99 - 3017 en

2nd Exchange

Product:
DEUTZ



TR

Date: 01.08.2004

This Circular supersedes 0199-99-3017, 06.09.2002

Copies to:

- Service- Partners At Home and Abroad (subsidiaries, agencies, dealers)
- Service Centers At Home
- Pocket Book Holders
- Company Departments (02)
- Original equipment manufacturers (OEM) or end customers

Drawn up by: VS-TI 1 Phone: +49 (0) 621 3 84-88 40
Fax: +49 (0) 621 3 84-88 41

Adress:

Note: The part numbers indicated in this document serve technical explanation purposes.
Exclusively the spare parts documentation is binding for the definition of spare parts.

DEUTZ Gas Engines - Fuel gas

1. General

Fuel gas is the term used to describe gas mixtures of varying composition, calorific value and anti-knock index which are suitable for use in gas engines.

The knock rating is given by the methane number (MN), where

MN = 100 (antiknock) is defined for methane (CH₄) and
MN = 0 (high level of knocking) is defined for hydrogen (H₂).

In the case of gases with variable or low methane numbers there is a risk of knocking and hence the risk of extreme mechanical and thermal stress with possible consequential damage.

The methane number of combustion gas mixtures is influenced by several components. Thereby the main components are:

- Methane - CH₄ - as the most significant component of the standard gas engine combustion gas, particularly in the case of the diverse natural gases.
- Hydrogen - H₂ - which significantly reduces the methane number of the gas mixture. It is mainly present in combustion gases such as coke oven, blast furnace and low-temperature carbonization gases.
- Higher levels of hydrocarbons - C_nH_m with n>1 and m>4 - in other words more hydrocarbons than methane, which are often very unstable and therefore tend much more to knocking.
- Inert N₂ and CO₂ - which do not take an active part in the combustion process, but instead increase the methane number in a gas mixture, thereby CO₂ has three times the effect of N₂.

For the assessment of a gas with respect to its suitability as a combustion gas the attendant materials in the gas are of great importance. It is true that they have (mostly) no influence on the actual combustion process, but with respect to the reliable operation of the engine and plant in general these attendant gas materials must always be taken into account.

These attendant gas materials are released when the gas is generated in sewage treatment works, landfill sites or biogas plants. They consist of minerals, halogens, metals, heavy metals etc., which form a link with the hydrocarbons. Depending on the quantity and the damaging effect these attendant gas materials must be filtered out of the combustion gas in front of the engine. The limiting values of the significant attendant gas materials, which are known of at present, are listed in Table 2.

2. Classification into gas groups

The possible combustion gases are classified into different groups according to their abrasive properties. In this way the respective maintenance plan in the operation manual can be assigned to the engine.

Engines, which we have supplied, may only be operated with the combustion gas for which they were planned according to the scope of supply. If you wish to change the combustion gas then please contact DEUTZ first.

Gas group 1	Gas group 2 (bio-gases)
Natural gas	sewage gas
Pit gas	methane gas
Liquified gas - propane, butane, LNG (liquid natural gas)	Wood gas
Attendant petroleum gas (petroleum gas)	other bio-gases
Gases with a hydrogen content, $H_2 > 30 \text{ Vol}\%$, e.g. coke oven gas	

Table 1 Classification into gas groups

3. Minimum properties of combustion gases for gas engines



Please note:

- The minimum properties for which an engine operation is still possible are given. However, the max. possible power of the engine is not given in all cases,
- For the engine-specific requirements of the respectively approved combustion gases see Table 3.
- The given minimum properties are only valid for the engine. For plant parts the respective manufacturer's documentation should be followed, see also Table 4.

Property	Desc.	Unit	Limit	Remark
Calorific value (lower cal. val.)	H_u	[kWh/m ³]	≥ 4	
Rate of increase H_u		[%/min]	< 5	
CO_2/H_u	CO_2/H_u	[Vol%/kWh/m ³]	< 10	
Sulphur content (total) or H_2S content	S H_2S	[mg/m ³ CH ₄] [Vol%/m ³ CH ₄]	< 2200 < 0,15	Due to corrosion in the engine
Chlorine content (total)	Cl	[mg/m ³ CH ₄]	< 100	
Fluorine content (total)	F	[mg/m ³ CH ₄]	< 50	
Sum of chlorine and fluorine	(Cl+F)	[mg/m ³ CH ₄]	< 100	
Ammonia	NH ₃	[mg/m ³ CH ₄]	< 30	
Dust content		[mg/m ³ CH ₄]	< 10	
Grain size		[µm]	3 - 10	
Oil gases > C5 < C10		[mg/m ³ CH ₄]	< 3000	No condensation in gas control system and the suction pipe
Oil gases > C10		[mg/m ³ CH ₄]	< 250	
Silicon (organic)	Si	[mg/m ³ CH ₄]	< 10	
Humidity (relative)	φ	[%]	< 80	At lowest air temperature
In general no condensation is permitted in the gas control system and the suction pipe				

Property	Desc.	Unit	Limit	Remark
Static pre-pressure upon entry to gas control system				
min		[mbar]	20	
max		[mbar]	100	
Gas pressure fluctuations		[%]	± 10	of the set value at the variation frequency < 10/h
Different values apply to gases with a hydrogen content $H_2 > 30$ Vol%, e.g. coke oven gas:				
Static pre-pressure on entry to the gas control system				
		[mbar]	> 60	
Gas pressure fluctuations		[%]	± 10	of the set value at the variation frequency < 3/min
Gas temperature				
		[°C]	< 50	
		[°C]	> 10	
Different values apply to gases with a hydrogen content $H_2 > 30$ Vol%, e.g. coke oven gas:				
Gas temperature				
		[°C]	> 25	due to lack of gas constituents, e.g. Naphthalene
Different values apply to liquid gas - propane, butane, LNG (liquid natural gas):				
Gas temperature				
		[°C]	> 35	
Variations in the composition of gases with a hydrogen content $H_2 > 30$ Vol%, e.g. coke oven gas				
Hydrogen	H_2	[%]	± 3	
Methane	CH_4	[%]	± 3	
Rest		[%]	± 5	
Limit values for attendant materials for gases with a hydrogen content $H_2 > 30$ Vol%, e.g. coke oven gas:				
Naphthalene		[mg/10kWh]	< 200	
Benzene		[mg/10kWh]	< 25000	
Tar		[mg/10kWh]	< 0,5	

Table 2 Minimum properties of combustion gases for gas engines

4. Engine-specific requirements of combustion gases

The gas types released according to the engine data sheet are listed in Table 3. It also shows the engine-specific limits required for different gases at maximum engine power.

Application	Composition	MN, min	Hu, min [kWh/m _n ³]	Remark
Engine TCG 2015				
Natural gas		70		
Sewer gas	65 % CH_4 / 35 % CO_2		5,0	
Landfill site gas	50 % CH_4 / 27 % CO_2 / Rest N_2		5,0	
Engine TBG 616				
Natural gas		70		
Sewer gas	65 % CH_4 / 35 % CO_2		5,0	
Landfill site gas	50 % CH_4 / 27 % CO_2 / Rest N_2		5,0	

Application	Composition	MN, min	Hu, min [kWh/m _n ³]	Remark
Engine TCG 2016				
Natural gas		80		
Sewer gas	65 % CH ₄ / 35 % CO ₂		5,0	
Landfill site gas	50 % CH ₄ / 27 % CO ₂ / Rest N ₂		5,0	
Engine TBG 620				
Natural gas		70		
Sewer gas	65 % CH ₄ / 35 % CO ₂		5,0	
Landfill site gas	50 % CH ₄ / 27 % CO ₂ / Rest N ₂		5,0	
Engine TCG 2020				
Natural gas		80		
Sewer gas	65 % CH ₄ / 35 % CO ₂		5,0	
Landfill site gas	50 % CH ₄ / 27 % CO ₂ / Rest N ₂		5,0	
Engine TCG 2032				
Natural gas		80		
Data for special gases and two-gas operation upon request or in the case of engines, which have already been delivered, according to the supplier documentation.				

Table 3 Engine-specific requirements

5. Project-related requirements

- If the required minimum properties of the combustion gas are not met or if it is contaminated with non-specified components the service life of the engine and its components will be reduced. The scheduled maintenance times given in the scheduled maintenance plan for the proper specified engine operation are often substantially fallen short of and hence lose their relevance completely.
- If the planned combustion gas does not meet the minimum properties given here or if the combustion gas contains additional by-products, which are not specified, and without the actual combustion gas analysis having been released in writing by DEUTZ, then any guarantee claims against DEUTZ or any form of liability by DEUTZ will be invalid
- At the time of commissioning, a gas analysis must be submitted (not older than 2 weeks) and the commissioning report must be attached. After commissioning, a gas analysis is to be carried out 3 times a year and a check made to see if the minimum properties are being complied with. In the event of a warranty claim, these gas analyses must be presented.
- The respective manufacturer's documentation should be followed for other plant parts. See also:
 - "The design of power plants with gas and diesel engine operation"
(Planning and installation advice)
of DEUTZAG
 - "Project Manual"
of DEUTZAG
- If catalysers and/or exhaust gas heat exchangers are used the respective manufacturer's information should be followed with respect to the permitted gas composition and exhaust gas temperature.

Table 4 Project-related requirements

6. Sampling and gas analysis

Sampling and gas analyses are to be carried out according to the relevant standards and guidelines.

We recommend Tedlar bag sampling. This process is calibrated and suitable for determining SI compounds, chlorine, fluorine, sulphur, chlorinated hydrocarbons/chlorofluorocarbons and aromatic compounds from a sample. The sample can be used without problems affecting the pressure side of the compressor.

Sampling using the methanol impinger method (washing bottle method) or sampling on activated carbon (Draeger method) is only possible for SI compounds or, with limitations, also for chlorinated hydrocarbons/chlorofluorocarbons. Not all SI compounds remain stable and/or conversion processes occur. In addition to this, the gas volume must be determined exactly, which requires the corresponding equipment on site.

A selection of the analysis parameters is given here:

Analysis parameters	Method
Main components (O ₂ , CO ₂ , N ₂ , CH ₄)	DIN 51872-04-A
Total chlorine, fluorine, sulphur using the Wickbold method	DIN EN 38409 H8 (Wickbold combustion) DIN EN ISO 10304-1 (Ion chromatography)
Total silicon/org. Silicon compounds	in appendix VDI 3865, sheet 4
Ammonia	VDI 2461, sheet 2, Nessler process
Hydrogen sulphide	DIN 51855-4; VDI 3486, Sheet 2

Table 5 Sampling and gas analysis

SI compounds which must also be analyzed with gas chromatography as a minimum requirement:

for landfill sites:
Trimethylsilanol Hexamethyldisilanol (L2) Octamethylcyclotetrasilanol (D4) Decamethylcyclopentasilanol (D5)
for sewage treatment works also:
Hexamethylcyclotrisilanol (D3)

Table 6 SI compounds

7. Examples for the methane number (MN) for selected gases

Biogas	MN > 120
Pit gas	MN ≅ 105
Methane	MN = 100
Natural gas	MN = 65 - 95
Propane	MN = 33
Butane	MN = 10
Hydrogen	MN = 0

DEUTZAG

Service-Technology

i.V. Sonntag
- Sonntag -

i. A. Boos
- Boos -

This page intentionally left blank.

General Safety Regulations

Medium and Large Size Engines

0297 7857 en

Reprinting and reproduction of any kind, even in form of excerpts, requires our written approval.



Table of Contents

- 1 General Safety Regulations**
 - 1.1 Selection and qualification of personnel**
 - 1.2 Organizational measures**
 - 1.3 Intended use**
 - 1.4 Symbols used**
 - ▶ **Warning signs**
 - ▶ **Prohibitive signs**
 - ▶ **Ordersigns**
 - ▶ **Notes**
 - ▶ **Stickers**
- 2 Safety Regulations for Medium and Large Size Engines**
 - 2.1 Transport**
 - 2.2 Operation**
 - 2.3 Fuels and lubricants**
 - ▶ **Diffusion fluids for flaw detection testing**
 - ▶ **Various cleansing agents**
 - ▶ **Liquid nitrogen**
 - ▶ **Fuel (liquid fuel and gas)**
 - ▶ **Lubrication oil**
 - ▶ **Coolant**
 - ▶ **Coolant pre-heating**
 - 2.4 Maintenance, inspection and repair**
 - ▶ **Electrics / electronics, general**
 - ▶ **Battery**
 - 2.5 Waste disposal / recycling / waste material**
 - ▶ **Waste disposal**
 - ▶ **Recycling**
 - ▶ **Waste material**



1 General Safety Regulations

This document has been published in various languages. In case of possible uncertainties or interpretative difficulties the German version is always decisive.

Each country (state) has its own safety regulations. No matter under which work and local conditions you are working - compliance with all private or public safety regulations of the respective country (state) and liability association is mandatory.

The safety regulations in this brochure must not be considered as being final for the complete unit (combustion engine and powered machine), because the assembly and interaction of combustion engine and powered machine requires further safety relevant measures.

The safety regulations issued by the machine manufacturer must therefore also be observed. Furthermore, the safety regulations on the respective worksheets in our operating instructions and workshop manuals must also be complied with.

1.1 Selection and qualification of personnel

Work on or with the combustion engine as well as on the complete machine must only be carried out by authorized specialists.

A legally specified minimum age must be observed.

Responsibilities for operation, set-up work, maintenance and repair must be clearly determined.

1.2 Organizational measures

The operating instructions must be handed out to the operating personnel. These must be always at hand at the operating location of the combustion engine, or, if this is not possible, in any other way accessible for the operating personnel.

With the help of the operating instructions the operating personnel must be instructed in the handling of the combustion engine, whereby all safety relevant information must be explained in particular. This is especially valid for persons who work on the machine only occasionally, e.g. for set-up or maintenance work. In addition to the operating instructions all generally valid legal or country specific regulations for the avoidance of accidents and the protection of the environment must also be complied with at the operating location.

Unauthorized changes to the engine can have an adverse effect on safety. The manufacturer will not assume liability for any damage resulting from this. Manipulations on the injection and governor system may also affect the performance and exhaust emission characteristics, so that compliance with legal environmental regulations can no longer be assured.

Only genuine DEUTZ parts may be used.

All notes and warning stickers attached to the engine must be observed and maintained in legible condition.

1.3 Intended use

The combustion engine is solely intended for the contractually determined purpose of use. Any other use or any use for applications exceeding the intended use is considered as unintended use. The manufacturer will not assume liability for any damage resulting from this. The user is the sole bearer of any risk.

Observing the operating instructions and compliance with the maintenance instructions is also part of the intended use.

1.4 Symbols used

The following warning, prohibitive, order signs and notes may be attached with various symbols. These have the following meaning:

▶ Warning sign



This symbol is used for all safety regulations the negligence of which will cause danger to health and life of the persons involved.



Warning of combustible materials



Warning of caustic substances



Warning of dangerous electrical voltage



Warning of harmful or irritating substances



Warning of dangers caused by batteries



Warning of hot surface

▶ Prohibitive signs



Fire, naked light and smoking prohibited!

▶ Ordersigns



Wear eye protection



Wear a hard hat



Wear ear defenders



Wear safety gloves



Wear safety clothes

▶ Notes



This symbol is used for all notes the negligence of which causes the risk of damage to material, malfunction and damage to the environment.

► Stickers



Stickers are used on the engine to give instructions and to highlight possible special danger sources which could lead to physical damage. Damaged or illegible stickers must be replaced immediately.

There are many possible danger sources during operation, set-up, inspection, repair or other work. Unfortunately it is not possible to fight all these dangers by attaching warning signs. It is therefore of utmost importance to have the engine operated and serviced by trained personnel concentrated on their work.

Note symbols and warning stickers are in compliance with the technical status at the date of delivery of the engine.

Due to technical and legal changes the safety regulations for the handling of combustion engines and the signs to be attached may also change. It is therefore very important to keep an eye on the latest technical developments.

2 Safety Regulations for Medium and Large Size Engines

2.1 Transport

- Use only transport devices specified by the manufacturer.
- Use only lifting gear recommended by the manufacturer.
- Use only the lifting points specified by the manufacturer.
- Transport the engine only in „as installed“ position.
- For transport lash the engine down only at the points specified by the manufacturer.
- After a transport distance of 50 km check the fastening for tight fit, retighten if necessary.

2.2 Operation

Check before or during commissioning:

- Safety installations for completeness and function!
- Lines, hoses and fittings for leaks!
- Intake and exhaust system for function and compliance with the installation specifications of the engine manufacturer!
- Run combustion engines only in appropriately ventilated rooms, if necessary use a fume extraction system. Ensure sufficient ventilation before starting in closed rooms!
- Never bridge the contacts of ignition switches, battery or starter. This can cause severe injury and/or damage to property.
- Before starting make sure that no persons are in the danger area of the engine!
- Due to the high risk of an explosion engines with compressed air starting system must not be started with the help of combustible gases and oxygen, even in cases of emergency!
- Start the engine only from the operator's stand.
- After a starting fault crank the engine without fuel injection!
- Do not perform several cold starts within a short period of time.



- Be extremely careful in the vicinity of rotating, moving and hot parts.
- In the vicinity of the running engine wear ear defenders.
- Please remember that wearing ear defenders will affect the perception of possible warning sounds. Watch out more intensely for visual alarm signals.
- During operation keep an eye on control lights and gauges.
- In case of deviation from the normal values, e.g. overheating, shut the engine down immediately and perform trouble shooting. If necessary contact the customer service department. Do not perform any temporary repairs yourself.
- Inspect the engine at least once every day, even better once per shift, for externally visible deficiencies and damage! In case of malfunction of the engine have the fault corrected immediately! This applies particularly for malfunctions which could impair the safety, shut the engine down!
- Make sure the engine does not overshoot after being shut down!

2.3 Fuels and lubricants

▶ Diffusion fluids for flaw detection tests

- Danger of poisoning when working with trichloroethylene!
- Wear goggles and safety gloves!
- Avoid contact with skin and eyes!
- Ensure sufficient ventilation!
- Extract fumes, do not inhale!

▶ Various cleansing agents

- Observe the safety instructions of the individual manufacturers.
- Observe the waste disposal regulations, see also para.2.5.

▶ Liquid nitrogen

- Observe the safety instructions of the manufacturer.
- Wear goggles and safety gloves.
- Risk of perfrigeration.
- Disposal of fluid residues according to the instructions of the manufacturer, see also para. 2.5.

▶ Fuel (liquid fuel or gas)

- Fuel fumes and gases are harmful, do not inhale.
- Fuel fumes and gases are highly inflammable, do not smoke, do not use open fire, no formation of sparks.
- Do not refuel in closed rooms. However, if this cannot be avoided ensure an adequate supply of fresh air.
- Refuel only with the engine shut down.
- Catch running out fuel. Do not let it seep into the ground!
- Clean the engine from spilled fuel. Risk of combustion on hot engine parts.

- Always keep the tank tightly closed
- Do not lay cleaning cloths soaked in fuel on hot engine parts, risk of ignition.
- Ensure strict cleanliness.
- Do not open any components under pressure, e.g. injection lines or similar.
- When checking the injection jet keep your hands away from the fuel jet.
- Dispose of replaced filter cartridges environmentally.
- Observe the waste disposal regulations, see also para. 2.5.
- Work on injection pumps and on the control linkages between speed governor and injection pump are only permitted in **emergencies** and must be checked and, if necessary, readjusted by the DEUTZ service **as soon as possible**.

▶ **Lubrication oil**

- Oils in engine, transmission or hydraulic system can be under pressure or very hot after operation of the engine. Before starting work or inspections in such systems the pressure should be relieved by following the instructions of the manufacturer and safety gloves and goggles should be worn to avoid burning or scalding.
- Before starting work on oil circuits apply appropriate measures to collect possibly leaking out oil.
- Always ensure strict cleanliness.
- Before disassembling shut down the engine as specified in the operating instructions.
- Laboratory tests revealed that the permanent contact with engine oil will cause cancer. After work all skin areas in contact with engine oil should be thoroughly cleaned with water and soap.
- Do not lay oily cleaning cloths on hot engine parts, risk of ignition.
- Dispose of oily rags, filters etc. environmentally.
- Wipe up any spilled oil from the floor or any other walk-along areas immediately.
Danger of slipping.
- Make sure that oil does not get in contact with rubber or plastic parts of the engine. Such components could be destroyed by oil and cause severe material damage or bodily injury during later operation.
- Dispose of any oil dropping down while taking oil samples or oil filter service environmentally together with the filter cartridge.
- Service the lubrication oil centrifuge only when the engine is stopped.
Dispose of dirt and lubrication oil environmentally.
- Dispose of dirty lubrication oil environmentally.
- Dispose of oily air filter elements environmentally.
- Observe the waste disposal instructions, see para. 2.5.

▶ **Coolant**

- Wear safety gloves and goggles.
- Let the coolant cool down before opening the cooling system.
- The coolant is under pressure.
- Open the radiator cap slowly, danger of scalding by coolant squirting out or steam.
- Do not touch any engine components or coolant pipes. These are also very hot, danger of burning.
- Coolant additives are partly toxic, therefore avoid contact with skin and eyes, if necessary wash off immediately.
- Do not drink any coolant, danger of poisoning.
- Dispose of drained off or spilled coolant as specified by the manufacturer, see also para. 2.5. Do not let it seep into the ground.

▶ **Coolant pre-heating**

- Observe the documentation issued by the manufacturer of the coolant pre-heating system.

▶ **With coolant pre-heating system in operation**

- Hot coolant, danger of scalding, coolant system is under pressure.
- During pre-heating and engine operation the shut-off valves before and after the pre-heating unit must always be open, do not close!
- Do not touch any coolant conducting components, danger of burning.
- Before starting maintenance work switch the coolant pre-heating system off and make sure that it is not started again unintentionally.
Switch of the power supply to the unit.

▶ **With coolant pre-heating system switched off**

- The coolant system is under pressure.
- Before opening the coolant system the coolant must have cooled down.
- Close the shut-off valves at the coolant feed and discharge ports only before disassembling.
- During disassembly catch running out coolant, reuse it or dispose of environmentally, see also para 2.5.

2.4 Maintenance, inspection and repair

- Maintenance, inspection and repair work must generally be performed after the engine has been switched off and cooled down.
- With the engine in operation there is a risk of being injured by rotating and hot parts.
- The maintenance work specified in the operating instructions and in the workshop manual must be performed as scheduled and completely.
This ensures problem free, secure and environmental operation of the engine.

- Compliance with all legal and engine specific accident prevention instructions and safety regulations is mandatory.
- The work described in the operating instructions and in the workshop manual require, among others, the replacement of parts as well as fuels and lubricants. These replaced parts / fuels and lubricants must be stored, transported and disposed of as prescribed.
- Secure the engine against unintended starting, if necessary disconnect the battery or close the shut-off valve on the pressure vessel.
- Attach a warning sign to the operator's platform, e.g. „Do not start - maintenance work“.
- Have maintenance, inspection and repair work only performed by specially trained personnel.
- Clean engine and area around the engine thoroughly before starting work.
- Allow engine and machine components to cool down before starting work, if necessary wear safety gloves.
- Perform adjustments only with the engine shut down.
- If certain work is specified to be carried out with the engine running, all related safety regulations must be strictly followed.
- If the engine is installed in a vehicle, the respective vehicle must be parked on solid ground before starting work. The vehicle must additionally be secured against rolling.
- All tools needed for work must be clean and in perfect condition. Do not use tools misappropriately and do not make any temporary tools yourself.
- Use only the specified special tools.
- Use only the prescribed lifting gear and lifting tackle to remove assemblies or components.
- Place removed parts down well secured against tipping over, support if necessary.
- Use only liquid cleansers approved by the manufacturer to clean components or engine and dispose of these after use as specified by the manufacturer of the cleanser, see also para. 2.5.
- Do not use fuels or other combustible liquids for cleaning.
- Repair and cleaning work on fuel tanks must only be performed by specially trained personnel in compliance with all special safety regulations applicable for this purpose.
- When working on the fuel or gas system do not use open fire, do not smoke, no formation of sparks.
- Take care when disconnecting fluid conducting lines, the fluid may be hot and under pressure. Therefore relieve the pressure beforehand and apply preventive measures against scalding.
- Always wear safety gloves when checking for leaks in fluid systems.
Fluid jets penetrating the skin can cause severe bodily injury.
- Route and fasten lines for fluids and electrical system in a professional manner. Length, fittings and quality of the line must comply with the requirements.
- Before starting welding or torch cutting work disconnect the engine from ground, disconnect possibly available engine control modules.

- Do not perform any repairs on safety valves. Replace defective parts immediately!
- Before resuming operation make sure that all guards and safety installations, that had probably been removed, have been reinstalled.
- Make sure that there are no unauthorized persons near the engine when resuming operation.
- ▶ **Electrics / electronics, general**
 - Before starting work in the electrics/electronics de-energize the system, pull the ignition switch off. Compliance with the accident prevention instructions for electrical systems, e.g. VDE-0100/-0101/-0104/-0105 electrical precautions against dangerous contact voltages - is mandatory.
 - Do not touch any current conducting parts!
 - Mind the high electric voltage on ignition systems.
 - When cleaning with fluids all electrical and electronic components must be tightly covered.
 - Return electronic scrap to a specially set up collecting place, see also para. 2.5. Do not dispose off together with the domestic waste.
- ▶ **Battery**
 - When working with or on the battery the following regulations must be observed:
 - Always wear protective clothing when working with or on batteries. Wear at least goggles and safety gloves.
 - The battery electrolyte contains acid. Contact with skin, eyes and clothes must be strictly avoided. However, in case of any contact with skin and clothes neutralize the acid drops immediately with an acid converter or soap suds and rinse off with lots of water.
 - In case of eye contact rinse out immediately with clear water for at least 15 minutes and consult a physician immediately.
 - If acid has been drunk call for medical help immediately.
 - Do not lay any tools on the battery (short circuit and danger of explosion).
 - Avoid the sparking when handling cables and electrical equipment.
 - Avoid short circuits.
 - During transport secure batteries against slipping and tipping over, insulate the plus pole.
 - When charging batteries open the individual cells, if this is possible, so that the the gases developing during the charging process can escape. These gases are harmful and explosive, therefore always ensure sufficient ventilation and avoid sparking and smoking.
 - Do not tip the battery over, acid may seep out of the degassing openings.
 - Be extremely careful when connecting and disconnecting the battery charger. Strictly comply with the operating instructions of the manufacturer of the battery charger.
 - Return old and defective batteries to the to the supplier or a specially set up collecting place, see also para. 2.5. Do not dispose of together with domestic waste.

2.5 Waste disposal / recycling / waste material

▶ Waste disposal

Waste disposal includes measures and technical methods for the disposal of residues (e.g. metal, plastic material, rubber), fuels and lubricants (e.g. lubrication oil, coolant, fuel), other fluids (e.g. cleansing agents, degreasing agents) as well as waste material (e.g. sealing and screw retention agents, grease, glue).

In this context recycling (reuse) of these residues, fuels and lubricants as well as waste materials has priority.

Details concerning waste disposal and its monitoring are controlled by regional, national and international laws and regulations, which must be observed by the operating company in their own responsibility.

It is recommended to file any evidence on the disposal of wastes that require special monitoring.

▶ Recycling

Recycling is a general term for the material recovery of residues, fuels and lubricants as well as waste materials.

▶ Waste materials

Waste materials are all mobile objects the owner wants to or has to get rid of.

Objects which arise during production or service work, as well as objects the owner no longer has any use for.

The avoidance of waste material has priority.

Unavoidable wastes should, as far as possible, be recovered materially or energetically.

Waste to be disposed of is waste that cannot be recovered.



Notes: